



74AC109, 74ACT109 Dual JK Positive Edge-Triggered Flip-Flop

Features

- I_{CC} reduced by 50%
- Outputs source/sink 24mA
- ACT109 has TTL-compatible inputs

General Description

The AC/ACT109 consists of two high-speed completely independent transition clocked JK flip-flops. The clocking operation is independent of rise and fall times of the clock waveform. The JK design allows operation as a D-Type flip-flop (refer to AC/ACT74 data sheet) by connecting the J and K inputs together.

Asynchronous Inputs:

- LOW input to \bar{S}_D (Set) sets Q to HIGH level
- LOW input to \bar{C}_D (Clear) sets Q to LOW level
- Clear and Set are independent of clock
- Simultaneous LOW on \bar{C}_D and \bar{S}_D makes both Q and \bar{Q} HIGH

Ordering Information

Order Number	Package Number	Package Description
74AC109SC	M16A	16-Lead Small Outline Integrated Circuit (SOIC), JEDEC MS-012, 0.150" Narrow
74AC109SJ	M16D	16-Lead Small Outline Package (SOP), EIAJ TYPE II, 5.3mm Wide
74AC109MTC	MTC16	16-Lead Thin Shrink Small Outline Package (TSSOP), JEDEC MO-153, 4.4mm Wide
74ACT109SC	M16A	16-Lead Small Outline Integrated Circuit (SOIC), JEDEC MS-012, 0.150" Narrow
74AC109MTC	MTC16	16-Lead Thin Shrink Small Outline Package (TSSOP), JEDEC MO-153, 4.4mm Wide
74ACT109PC	N16E	16-Lead Plastic Dual-In-Line Package (PDIP), JEDEC MS-001, 0.300" Wide

Device also available in Tape and Reel. Specify by appending suffix letter "X" to the ordering number.

Connection Diagram

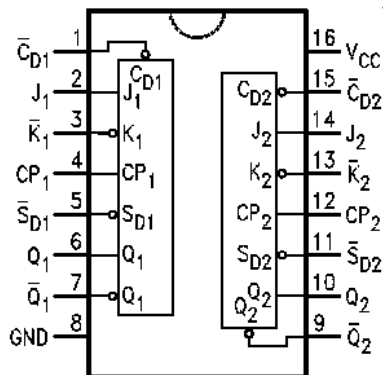

Pin Descriptions

Pin Names	Description
J ₁ , J ₂ , \bar{K}_1 , \bar{K}_2	Data Inputs
CP ₁ , CP ₂	Clock Pulse Inputs
\bar{C}_{D1} , \bar{C}_{D2}	Direct Clear Inputs
\bar{S}_{D1} , \bar{S}_{D2}	Direct Set Inputs
Q ₁ , Q ₂ , \bar{Q}_1 , \bar{Q}_2	Outputs

FACT™ is a trademark of Fairchild Semiconductor Corporation.

Logic Symbols

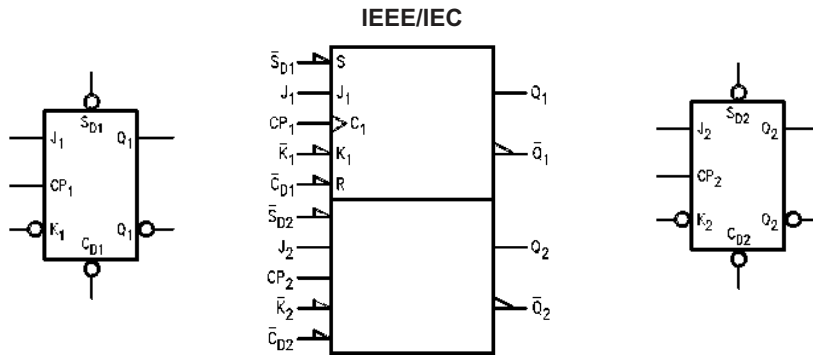

Truth Table

Each half.

Inputs					Outputs	
\bar{S}_D	\bar{C}_D	CP	J	K	Q	\bar{Q}
L	H	X	X	X	H	L
H	L	X	X	X	L	H
L	L	X	X	X	H	H
H	H	↗	L	L	L	H
H	H	↗	H	L	Toggle	
H	H	↗	L	H	Q_0	\bar{Q}_0
H	H	↗	H	H	H	L
H	H	L	X	X	Q_0	\bar{Q}_0

H = HIGH Voltage Level

L = LOW Voltage Level

↗ = LOW-to-HIGH Transition

X = Immaterial

$Q_0(\bar{Q}_0)$ = Previous $Q_0(\bar{Q}_0)$ before LOW-to-HIGH Transition of Clock

Logic Diagram

One half shown.

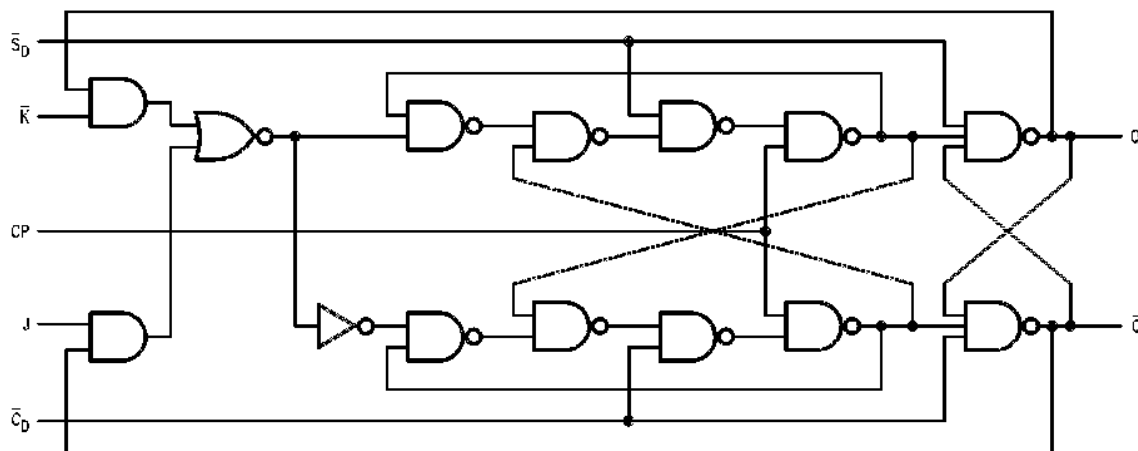

Please note that this diagram is provided only for the understanding of logic operations and should not be used to estimate propagation delays.

Absolute Maximum Ratings

Stresses exceeding the absolute maximum ratings may damage the device. The device may not function or be operable above the recommended operating conditions and stressing the parts to these levels is not recommended. In addition, extended exposure to stresses above the recommended operating conditions may affect device reliability. The absolute maximum ratings are stress ratings only.

Symbol	Parameter	Rating
V_{CC}	Supply Voltage	-0.5V to +7.0V
I_{IK}	DC Input Diode Current $V_I = -0.5V$ $V_I = V_{CC} + 0.5V$	-20mA +20mA
V_I	DC Input Voltage	-0.5V to $V_{CC} + 0.5V$
I_{OK}	DC Output Diode Current $V_O = -0.5V$ $V_O = V_{CC} + 0.5V$	-20mA +20mA
V_O	DC Output Voltage	-0.5V to $V_{CC} + 0.5V$
I_O	DC Output Source or Sink Current	$\pm 50mA$
I_{CC} or I_{GND}	DC V_{CC} or Ground Current per Output Pin	$\pm 50mA$
T_{STG}	Storage Temperature	-65°C to +150°C
T_J	Junction Temperature	140°C

Recommended Operating Conditions

The Recommended Operating Conditions table defines the conditions for actual device operation. Recommended operating conditions are specified to ensure optimal performance to the datasheet specifications. Fairchild does not recommend exceeding them or designing to absolute maximum ratings.

Symbol	Parameter	Rating
V_{CC}	Supply Voltage AC ACT	2.0V to 6.0V 4.5V to 5.5V
V_I	Input Voltage	0V to V_{CC}
V_O	Output Voltage	0V to V_{CC}
T_A	Operating Temperature	-40°C to +85°C
$\Delta V / \Delta t$	Minimum Input Edge Rate, AC Devices: V_{IN} from 30% to 70% of V_{CC} , V_{CC} @ 3.3V, 4.5V, 5.5V	125mV/ns
$\Delta V / \Delta t$	Minimum Input Edge Rate, ACT Devices: V_{IN} from 0.8V to 2.0V, V_{CC} @ 4.5V, 5.5V	125mV/ns

DC Electrical Characteristics for AC

Symbol	Parameter	V _{CC} (V)	Conditions	T _A = +25°C		T _A = -40°C to +85°C		Units		
				Typ.	Guaranteed Limits					
V _{IH}	Minimum HIGH Level Input Voltage	3.0	V _{OUT} = 0.1V or V _{CC} - 0.1V	1.5	2.1	2.1		V		
		4.5		2.25	3.15	3.15				
		5.5		2.75	3.85	3.85				
V _{IL}	Maximum LOW Level Input Voltage	3.0	V _{OUT} = 0.1V or V _{CC} - 0.1V	1.5	0.9	0.9		V		
		4.5		2.25	1.35	1.35				
		5.5		2.75	1.65	1.65				
V _{OH}	Minimum HIGH Level Output Voltage	3.0	I _{OUT} = -50μA	2.99	2.9	2.9		V		
		4.5		4.49	4.4	4.4				
		5.5		5.49	5.4	5.4				
		3.0	V _{IN} = V _{IL} or V _{IH} : I _{OH} = -12mA			2.56	2.46			
		4.5		I _{OH} = -24mA			3.86		3.76	
		5.5		I _{OH} = -24mA ⁽¹⁾			4.86		4.76	
V _{OL}	Maximum LOW Level Output Voltage	3.0	I _{OUT} = 50μA	0.002	0.1	0.1		V		
		4.5		0.001	0.1	0.1				
		5.5		0.001	0.1	0.1				
		3.0	V _{IN} = V _{IL} or V _{IH} : I _{OL} = 12mA			0.36	0.44			
		4.5		I _{OL} = 24mA			0.36		0.44	
		5.5		I _{OL} = 24mA ⁽¹⁾			0.36		0.44	
I _{IN} ⁽³⁾	Maximum Input Leakage Current	5.5	V _I = V _{CC} , GND		±0.1	±1.0		μA		
I _{OLD}	Minimum Dynamic Output Current ⁽²⁾	5.5	V _{OLD} = 1.65V Max.			75		mA		
I _{OHD}			V _{OHD} = 3.85V Min.			-75		mA		
I _{CC} ⁽³⁾	Maximum Quiescent Supply Current	5.5	V _{IN} = V _{CC} or GND		2.0	20.0		μA		

Notes:

1. All outputs loaded; thresholds on input associated with output under test.
2. Maximum test duration 2.0ms, one output loaded at a time.
3. I_{IN} and I_{CC} @ 3.0V are guaranteed to be less than or equal to the respective limit @ 5.5V V_{CC}.

DC Electrical Characteristics for ACT

Symbol	Parameter	V _{CC} (V)	Conditions	T _A = +25°C		T _A = -40°C to +85°C		Units
				Typ.	Guaranteed Limits			
V _{IH}	Minimum HIGH Level Input Voltage	4.5	V _{OUT} = 0.1V or V _{CC} - 0.1V	1.5	2.0	2.0		V
		5.5		1.5	2.0	2.0		
V _{IL}	Maximum LOW Level Input Voltage	4.5	V _{OUT} = 0.1V or V _{CC} - 0.1V	1.5	0.8	0.8		V
		5.5		1.5	0.8	0.8		
V _{OH}	Minimum HIGH Level Output Voltage	4.5	I _{OUT} = -50μA	4.49	4.4	4.4		V
		5.5		5.49	5.4	5.4		
		4.5	V _{IN} = V _{IL} or V _{IH} ; I _{OH} = -24mA		3.86	3.76		
		5.5	I _{OH} = -24mA ⁽⁴⁾		4.86	4.76		
V _{OL}	Maximum LOW Level Output Voltage	4.5	I _{OUT} = 50μA	0.001	0.1	0.1		V
		5.5		0.001	0.1	0.1		
		4.5	V _{IN} = V _{IL} or V _{IH} ; I _{OL} = 24mA		0.36	0.44		
		5.5	I _{OL} = 24mA ⁽⁴⁾		0.36	0.44		
I _{IN}	Maximum Input Leakage Current	5.5	V _I = V _{CC} , GND		±0.1	± 1.0		μA
I _{CCT}	Maximum I _{CC} /Input	5.5	V _I = V _{CC} - 2.1V	0.6		1.5		mA
I _{OLD}	Minimum Dynamic Output Current ⁽⁵⁾	5.5	V _{OLD} = 1.65V Max.			75		mA
I _{OHD}			V _{OHD} = 3.85V Min.			-75		mA
I _{CC}	Maximum Quiescent Supply Current	5.5	V _{IN} = V _{CC} or GND		2.0	20.0		μA

Notes:

- All outputs loaded; thresholds on input associated with output under test.
- Maximum test duration 2.0ms, one output loaded at a time.

AC Electrical Characteristics for AC

Symbol	Parameter	V_{CC} (V) ⁽⁶⁾	$T_A = +25^\circ\text{C}$, $C_L = 50\text{pF}$			$T_A = -40^\circ\text{C to } +85^\circ\text{C}$, $C_L = 50\text{pF}$		Units
			Min.	Typ.	Max.	Min.	Max.	
f_{MAX}	Maximum Clock Frequency	3.3	125	150		100		MHz
		5.0	150	175		125		
t_{PLH}	Propagation Delay, CP_n to Q_n or \bar{Q}_n	3.3	4.0	8.0	13.5	3.5	16.0	ns
		5.0	2.5	6.0	10.0	2.0	10.5	
t_{PHL}	Propagation Delay, CP_n to Q_n or \bar{Q}_n	3.3	3.0	8.0	14.0	3.0	14.5	ns
		5.0	2.0	6.0	10.0	1.5	10.5	
t_{PLH}	Propagation Delay, \bar{C}_{Dn} or \bar{S}_{Dn} to Q_n or \bar{Q}_n	3.3	3.0	8.0	12.0	2.5	13.0	ns
		5.0	2.5	6.0	9.0	2.0	10.0	
t_{PHL}	Propagation Delay, \bar{C}_{Dn} or \bar{S}_{Dn} to Q_n or \bar{Q}_n	3.3	3.0	10.0	12.0	3.0	13.5	ns
		5.0	2.0	7.5	9.5	2.0	10.5	

Note:

6. Voltage range 3.3 is $3.3\text{V} \pm 0.3\text{V}$. Voltage range 5.0 is $5.0\text{V} \pm 0.5\text{V}$.

AC Operating Requirements for AC

Symbol	Parameter	V_{CC} (V) ⁽⁷⁾	$T_A = +25^\circ\text{C}$, $C_L = 50\text{pF}$		$T_A = -40^\circ\text{C to } +85^\circ\text{C}$, $C_L = 50\text{pF}$		Units
			Typ.	Guaranteed Minimum	Typ.	Guaranteed Minimum	
t_S	Setup Time, HIGH or LOW, J_n or \bar{K}_n to CP_n	3.3	3.5	6.5	7.5	ns	
		5.0	2.0	4.5	5.0		
t_H	Hold Time, HIGH or LOW, J_n or \bar{K}_n to CP_n	3.3	-1.5	0	0	ns	
		5.0	-0.5	0.5	0.5		
t_W	Pulse Width, \bar{C}_{Dn} or \bar{S}_{Dn}	3.3	2.0	7.0	7.5	ns	
		5.0	2.0	4.5	5.0		
t_{REC}	Recovery Time, \bar{C}_{Dn} or \bar{S}_{Dn} to CP_n	3.3	-2.5	0	0	ns	
		5.0	-1.5	0	0		

Note:

7. Voltage range 3.3 is $3.3\text{V} \pm 0.3\text{V}$. Voltage range 5.0 is $5.0\text{V} \pm 0.5\text{V}$.

AC Electrical Characteristics for ACT

Symbol	Parameter	V _{CC} (V) ⁽⁸⁾	T _A = +25°C, C _L = 50pF			T _A = -40°C to +85°C, C _L = 50pF		Units
			Min.	Typ.	Max.	Min.	Max.	
f _{MAX}	Maximum Clock Frequency	5.0	145	210		125		MHz
t _{PLH}	Propagation Delay, CP _n to Q _n or \bar{Q}_n	5.0	4.0	7.0	11.0	3.5	13.0	ns
t _{PHL}	Propagation Delay, CP _n to Q _n or \bar{Q}_n	5.0	3.0	6.0	10.0	2.5	11.5	ns
t _{PLH}	Propagation Delay, \bar{C}_{Dn} or \bar{S}_{Dn} to Q _n or \bar{Q}_n	5.0	2.5	5.5	9.5	2.0	10.5	ns
t _{PHL}	Propagation Delay	5.0	2.5	6.0	10.0	2.0	11.5	ns
	\bar{C}_{Dn} or \bar{S}_{Dn} to Q _n or \bar{Q}_n							

Note:

8. Voltage range 5.0 is 5.0V ± 0.5V

AC Operating Requirements for ACT

Symbol	Parameter	V _{CC} (V) ⁽⁹⁾	T _A = +25°C, C _L = 50pF	T _A = -40°C to +85°C, C _L = 50pF		Units
			Typ.	Guaranteed Minimum		
t _S	Setup Time, HIGH or LOW, J _n or \bar{K}_n to CP _n	5.0	0.5	2.0	2.5	ns
t _H	Hold Time, HIGH or LOW, J _n or \bar{K}_n to CP _n	5.0	0	2.0	2.0	ns
t _W	Pulse Width, CP _n or \bar{C}_{Dn} or \bar{S}_{Dn}	5.0	3.0	5.0	6.0	ns
t _{rec}	Recovery Time, \bar{C}_{Dn} or \bar{S}_{Dn} to CP _n	5.0	-2.5	0	0	ns

Note:

9. Voltage range 5.0 is 5.0V ± 0.5V

Capacitance

Symbol	Parameter	Conditions	Typ.	Units
C _{IN}	Input Capacitance	V _{CC} = OPEN	4.5	pF
C _{PD}	Power Dissipation Capacitance	V _{CC} = 5.0V	35.0	pF

Physical Dimensions (Continued)

Dimensions are in millimeters unless otherwise noted.

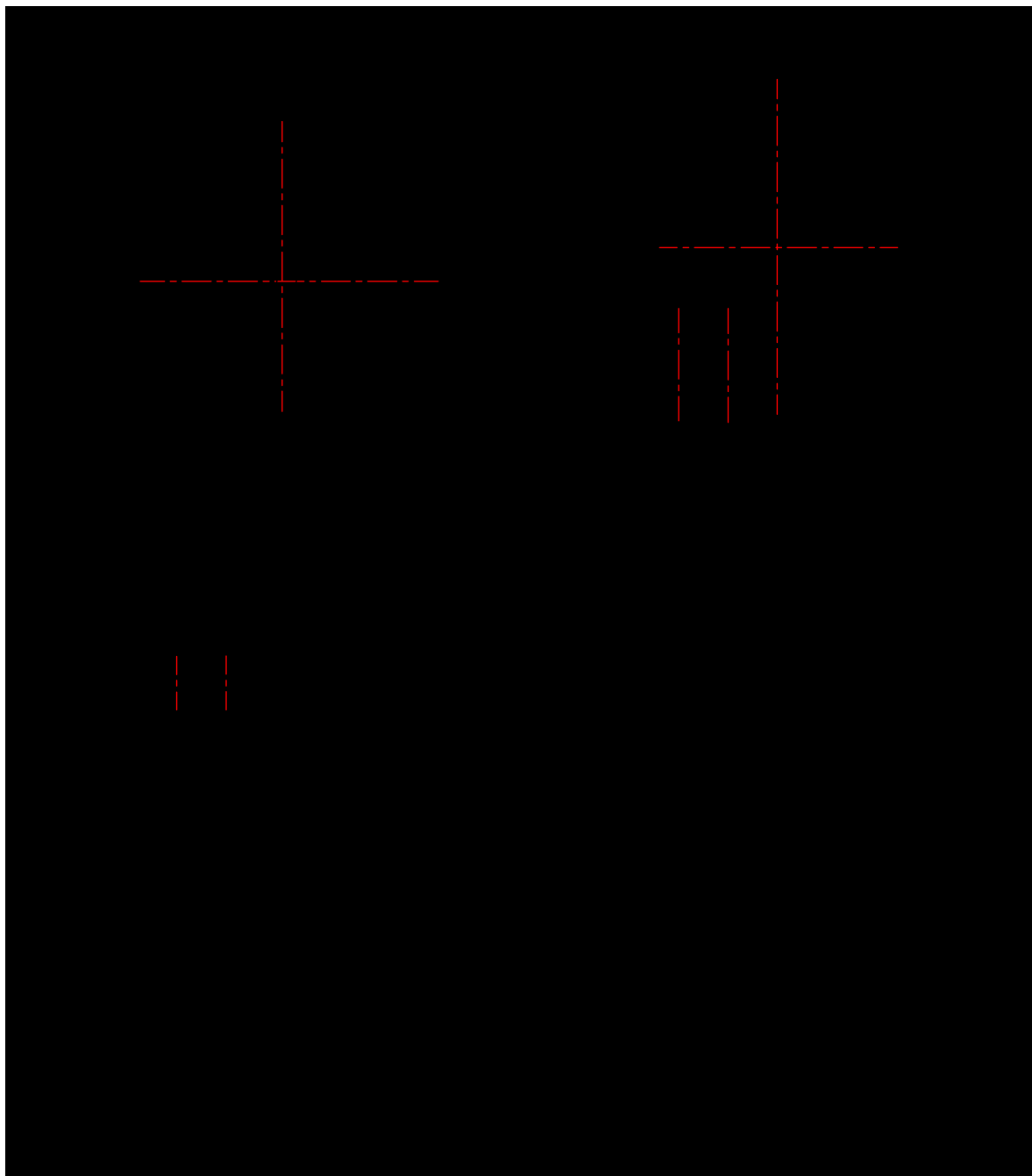

**Figure 2. 16-Lead Small Outline Package (SOP), EIAJ TYPE II, 5.3mm Wide
Package Number M16D**

Physical Dimensions (Continued)

Dimensions are in millimeters unless otherwise noted.

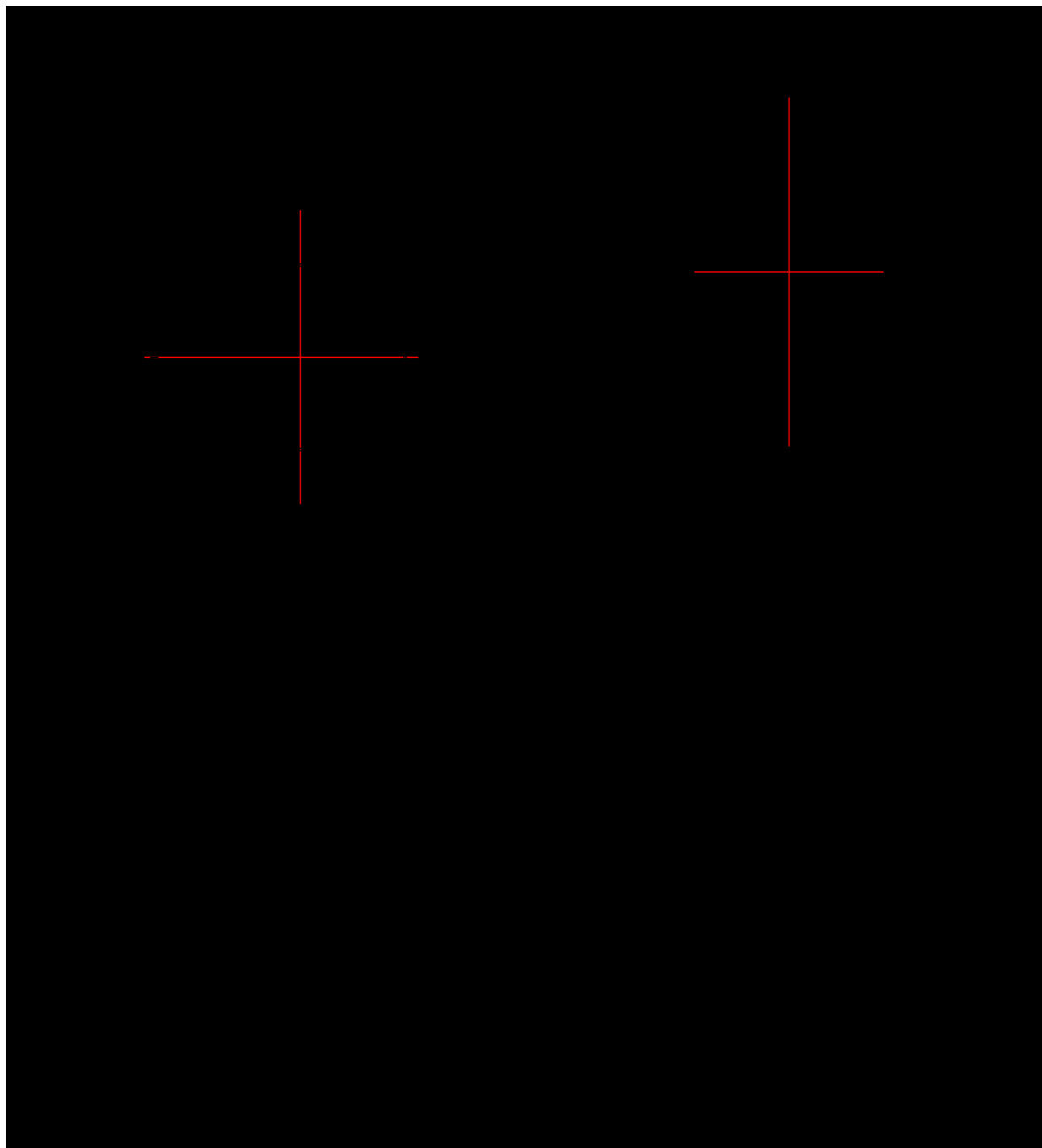

**Figure 3. 16-Lead Thin Shrink Small Outline Package (TSSOP), JEDEC MO-153, 4.4mm Wide
Package Number MTC16**

Physical Dimensions (Continued)

Dimensions are in inches (millimeters) unless otherwise noted.

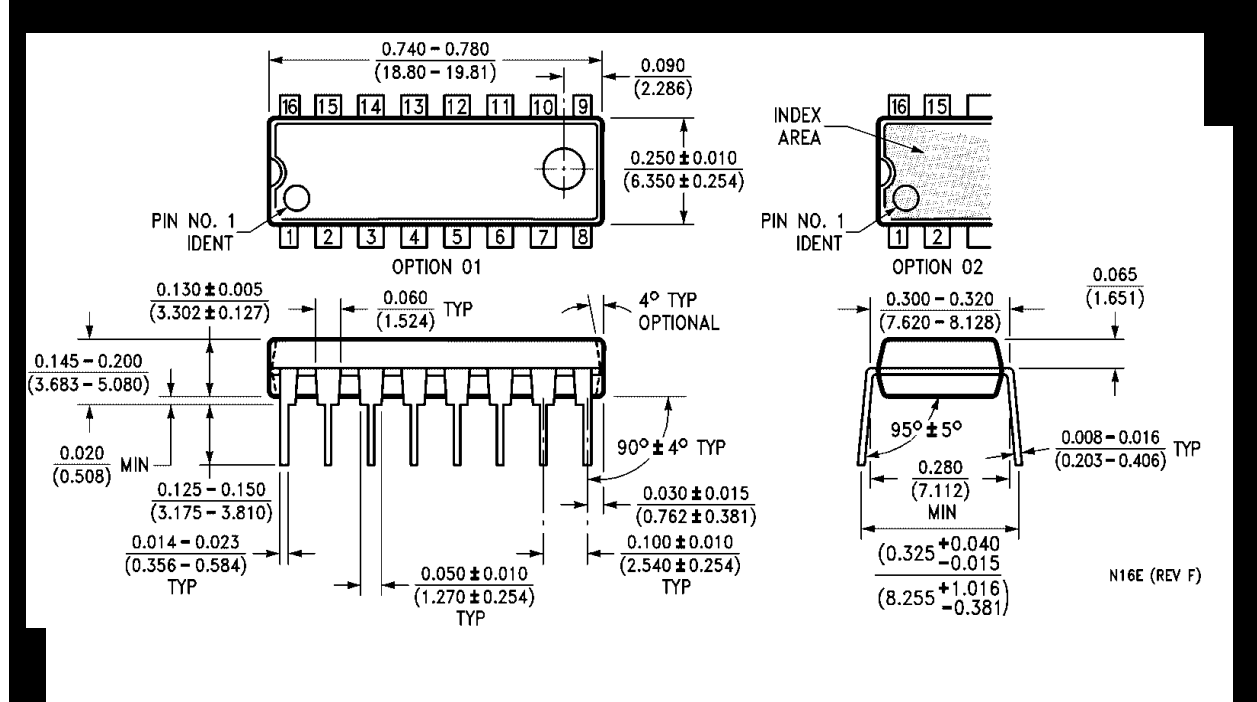

Figure 4. 16-Lead Plastic Dual-In-Line Package (PDIP), JEDEC MS-001, 0.300" Wide Package Number N16E



5