

# BG-12350NB

(12V 35Ah/10hr)

Rechargeable Sealed Lead Acid Battery



Technical Specification Sheet



These rechargeable batteries are lead-lead dioxide systems. The dilute sulfuric acid electrolyte is absorbed by separators and thus immobilized. Should the battery be accidentally overcharged producing hydrogen and oxygen, special one-way valves allow the gases to escape thus avoiding excessive pressure build-up. Otherwise, the battery is completely sealed and is, therefore, maintenance-free, leak proof and usable in any position.

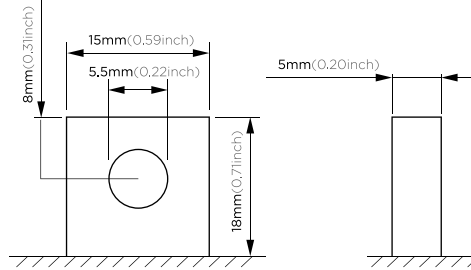

Terminal Dimensions

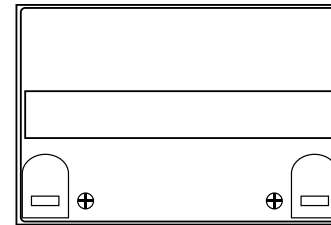
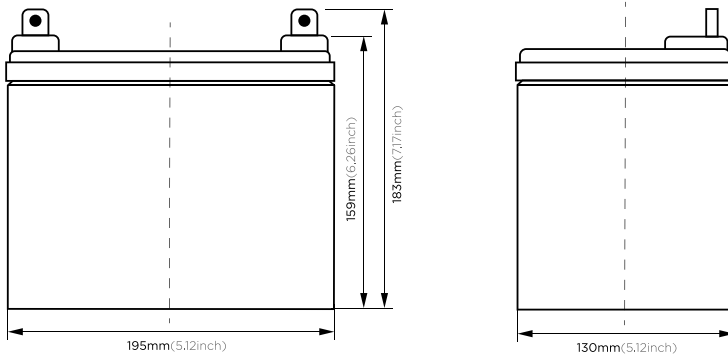

## Application

- Alarm System
- Cable Television
- Communication Equipment
- Control Equipment
- Security System
- Medical Equipment
- UPS
- Power tools
- Emergency Power System
- Toys

## Performance Characteristics

<b>Designed Floating Life</b>	8 Years			
<b>Capacity (25°C)</b>	20HR (1.8A,1.75V)	10HR (3.5A,1.75V)	5HR (6A,1.75V)	1HR (22A,1.75V)
	36AH	35AH	30AH	22AH
<b>Dimensions</b>	Length	Width	Height	Total Height
	195mm (7.71inch)	130mm (5.12inch)	159mm (6.26inch)	183mm (7.17inch)
<b>Approx. Weight</b>	11.8Kg (26.05lbs)			
<b>Internal Resistance</b>	Full charged at 25°C: 0.009 Ohm			
<b>Self Discharge</b>	3% of capacity declined per month at (25°C)			
<b>Capacity Affected by Temp. (20HR)</b>	40°C	25°C	0°C	-15°C
	102%	100%	85%	65%
<b>Charge Voltage (25°C)</b>	Cycle use		Float use	
	14.4-15V(-30mV/°C), max. Current: 8.75A		13.6-13.8V(-20mV/°C)	

## General Features

- Absorbent Glass Mat(AGM) technology for efficient gas recombination of up to 99% and freedom from electrolyte maintenance or water adding.
- Not restricted for air transport-complies with IATA/ICAO Special Provision A67.
- UL-recognized component.
- Can be mounted in any orientation.
- Computer designed lead, calcium tin alloy grid for high power density.
- Long service life, float or cyclic applications.
- Maintenance-free operation.
- Low self discharge.

## Battery Construction

Component	Positive plate	Negative plate	Container	Cover	Safety valve	Terminal	Separator	Electrolyte
Raw material	Lead dioxide	Lead	ABS	ABS	Rubber	Copper	Fiberglass	Sulfuric acid



**Charge characteristic**

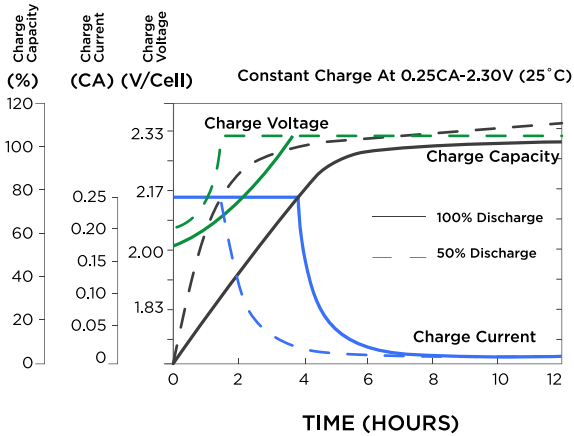

**Discharge characteristic (25°C)**

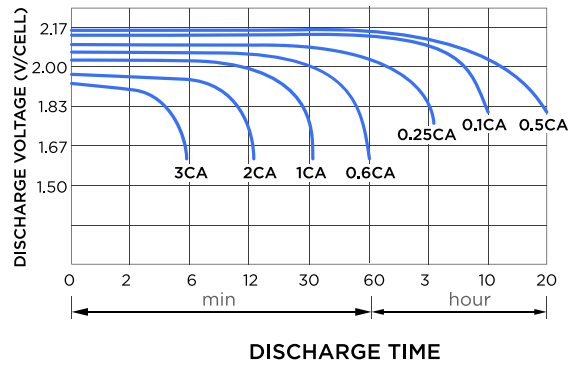

**Relationship of OCV and state of charge**

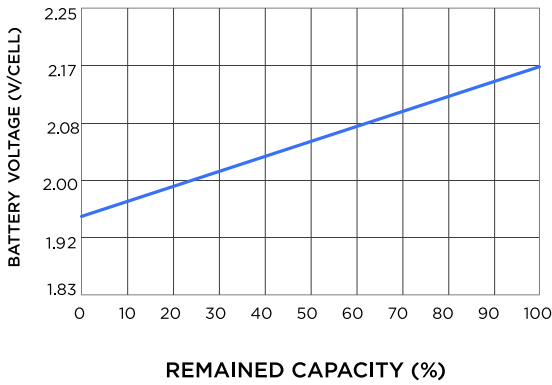

**Self-discharge characteristic**

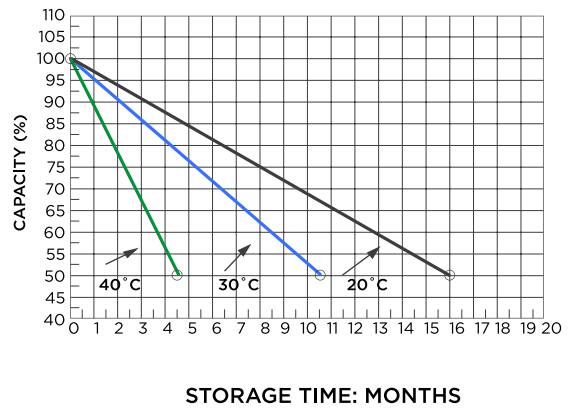

**Constant current discharge ratings-amperes at 77°F 25°C**

F. V / T i m e	5 min	10 min	15 min	30 min	1HR	3HR	5HR	10HR	20HR
1.60V	123	84.0	61.3	36.8	23.1	9.56	6.68	3.71	1.84
1.67V	110	76.7	59.5	35.7	23.1	9.52	6.62	3.66	1.84
1.70V	105	73.9	57.4	35.0	23.0	9.52	6.62	3.63	1.84
1.75V	93.1	68.3	54.3	34.3	22.8	9.45	6.57	3.57	1.83
1.80V	84.0	63.4	51.8	33.3	22.5	9.42	6.52	3.50	1.76
1.85V	63.7	52.2	44.8	30.6	22.2	9.38	6.46	3.44	1.66

**Constant power discharge ratings-watts at 77°F 25°C**

F. V / T i m e	5 min	10 min	15 min	30 min	1HR	3HR	5HR	10HR	20HR
1.60V	202	139	109	69.3	45.5	18.3	12.8	7.42	3.69
1.67V	191	138	107	67.9	44.0	18.3	12.8	7.31	3.68
1.70V	179	134	106	66.2	42.8	18.3	12.8	7.25	3.68
1.75V	167	125	99.4	64.4	42.5	18.1	12.6	7.13	3.66
1.80V	149	117	93.5	62.7	41.7	17.8	12.4	7.01	3.53
1.85V	120	96.6	81.6	57.4	41.3	17.7	12.3	6.88	3.32