

THIS DRAWING IS UNPUBLISHED. RELEASED FOR PUBLICATION
 © COPYRIGHT BY TYCO ELECTRONICS CORPORATION. ALL RIGHTS RESERVED.

LOC	DIST	REVISIONS			
P	LTR	DESCRIPTION	DATE	DWN	APVD
-	-				
D1		UPDATE PER ECO-05-010808	3 OCT 05	CAS	MKS

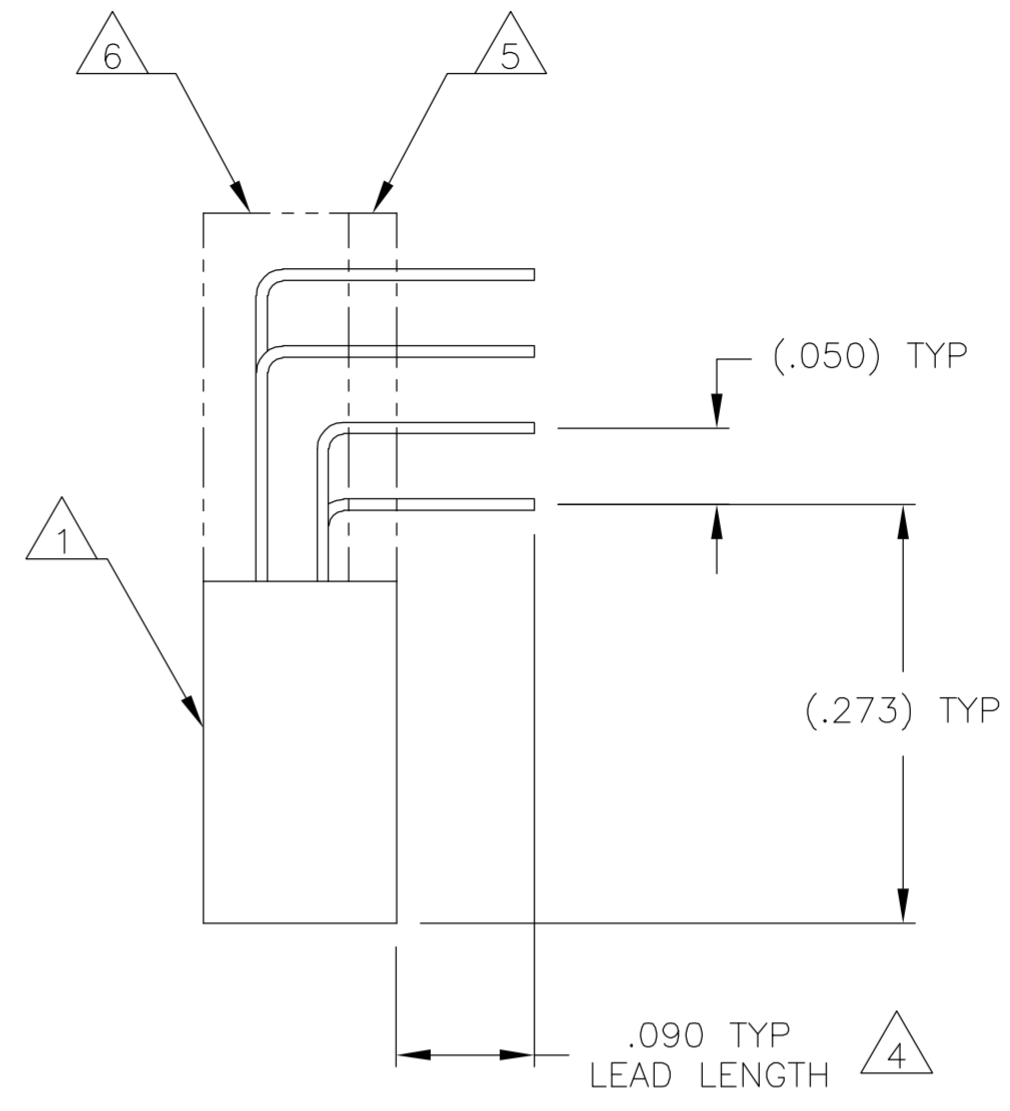
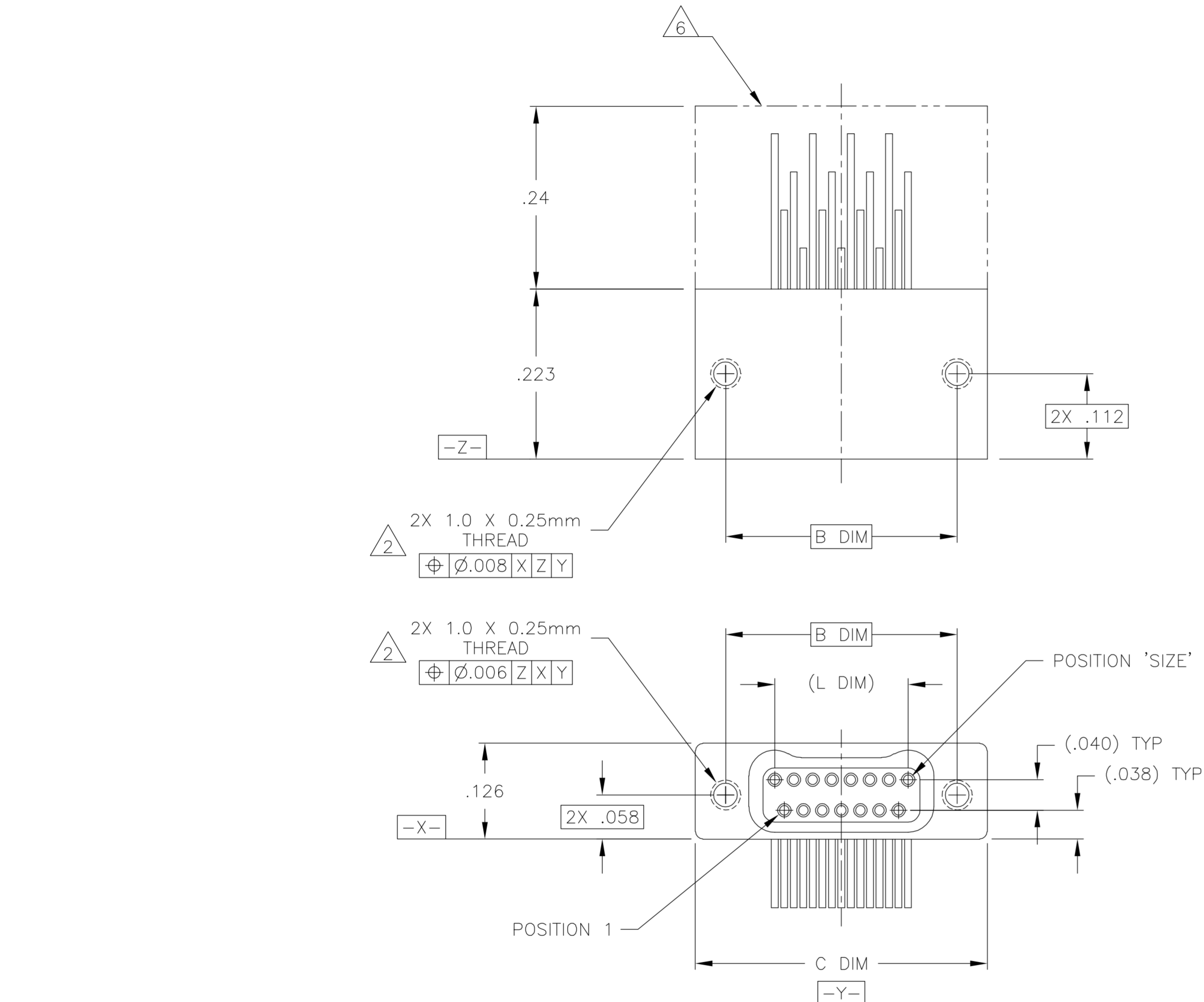

SIZE	B DIM	C DIM ±.0050	(L DIM)
09	.229	.3085	(.100)
15	.304	.3835	(.175)
25	.429	.5085	(.300)
37	.579	.6585	(.450)
51	.754	.8335	(.625)
65	.929	1.0085	(.800)

- 1 SHELL OPTIONS (TO BE SPECIFIED IN NANONICS PART NUMBER):
 METAL: 6061-T6 ALUMINUM, ELECTROLESS NICKEL PLATED PER SAE-AMS-C-26074 (STANDARD) OR GOLD PLATED PER ASTM B488
 303 STAINLESS STEEL, PASSIVATED PER SAE-AMS-2700
 INSULATOR MATERIAL FOR ALL METAL SHELLS IS LIQUID CRYSTAL POLYMER (LCP) PER MIL-M-24519 OR PER ASTM D5138
- 2 PLASTIC: LIQUID CRYSTAL POLYMER (LCP) PER MIL-M-24519 OR PER ASTM D5138
 STANDARD 1.00UNM CAPTIVE JACKSCREWS ARE SHOWN FOR REFERENCE ONLY AND MUST BE SPECIFIED IN THE NANONICS PART NUMBER WHEN REQUIRED. JACKSCREW MATERIAL IS 303 STAINLESS STEEL, PASSIVATED PER SAE-AMS-2700, AND DRY LUBED PER DOD-L-85645. RETAINING RING IS 17-4 STAINLESS STEEL, PASSIVATED PER SAE-AMS-2700. JACKSCREWS HAVE A .9mm HEX SOCKET HEAD. 1.20UNM JACKSCREWS ALSO AVAILABLE.
- 3 MOUNTING HARDWARE IS AVAILABLE WITH THIS CONFIGURATION (NOT SHOWN). HARDWARE MUST BE SPECIFIED IN THE NANONICS PART NUMBER. CONSULT TYCO ELECTRONICS FOR DETAILS.
- 4 LEAD MATERIAL: BeCu, TIN LEAD PLATED PER 60/40 COMPOSITION PER SAE-AMS-P-81728
- 5 INSULATOR BOARD MATERIAL: G10 OR EQUIVALENT
- 6 EPOXY ENCAPSULATION USING FREY CF-3003 EPOXY
- 7 NANONICS TERMINATION CODE: M9
- 8 THIS DRAWING PREVIOUSLY IDENTIFIED AS NANONICS N10138/256

THIS DRAWING IS A CONTROLLED DOCUMENT.		DWN M STORRY 31 AUG 00	Tyco Electronics Corporation Harrisburg, PA 17105-3608	
DIMENSIONS: INCHES	TOLERANCES UNLESS OTHERWISE SPECIFIED:	CHK -	NAME	
	0 PLC ± -	APVD -	PRODUCT SPEC	
	1 PLC ± -	PRODUCT SPEC	RECP ASSEMBLY, HORIZONTAL MOUNT, INVERTED, THROUGH HOLE, 2 TO 4 ROW, .050 SPACING, PLASTIC OR METAL,	
	2 PLC ± .010	APPLICATION SPEC	SIZE A2	CAGE CODE OPJN9
	3 PLC ± .005	WEIGHT -	DRAWING NO C=1589489	RESTRICTED TO -
MATERIAL SEE NOTES	FINISH SEE NOTES	CUSTOMER DRAWING	SCALE 8:1	SHEET 1 of 2
			REV D1	

THIS DRAWING IS UNPUBLISHED. RELEASED FOR PUBLICATION
 © COPYRIGHT BY TYCO ELECTRONICS CORPORATION. ALL RIGHTS RESERVED.

LOC		DIST		REVISIONS			
P	LTR	DESCRIPTION	DATE	DWN	APVD		
-	-	SEE SHEET 1	-	-	-		

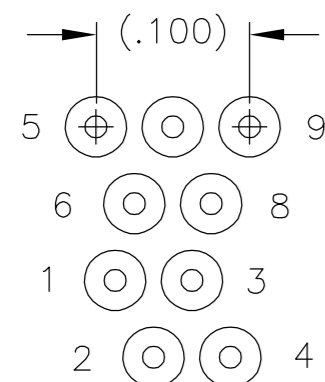

9 POSITION

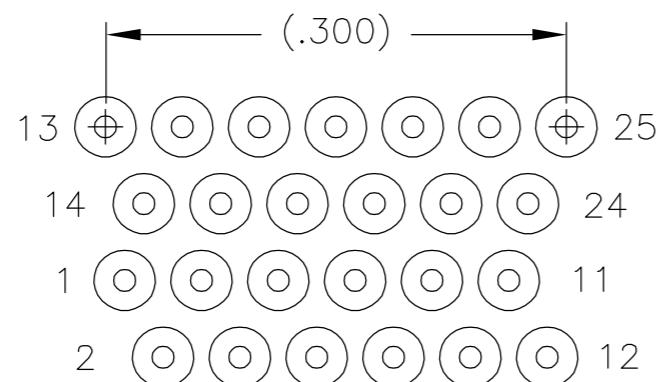

25 POSITION

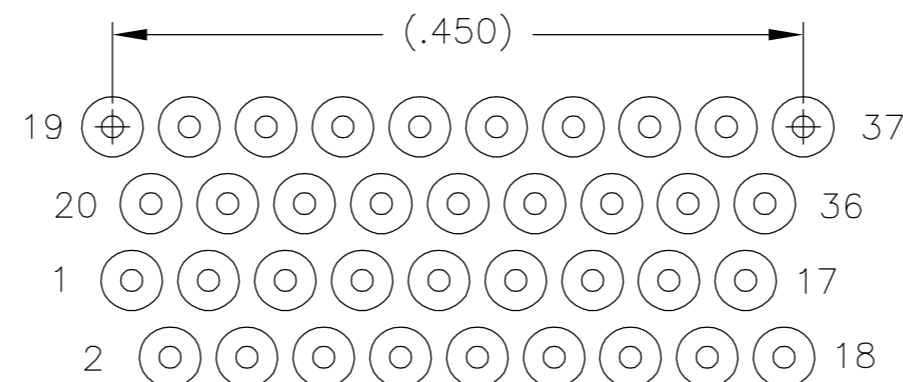

37 POSITION

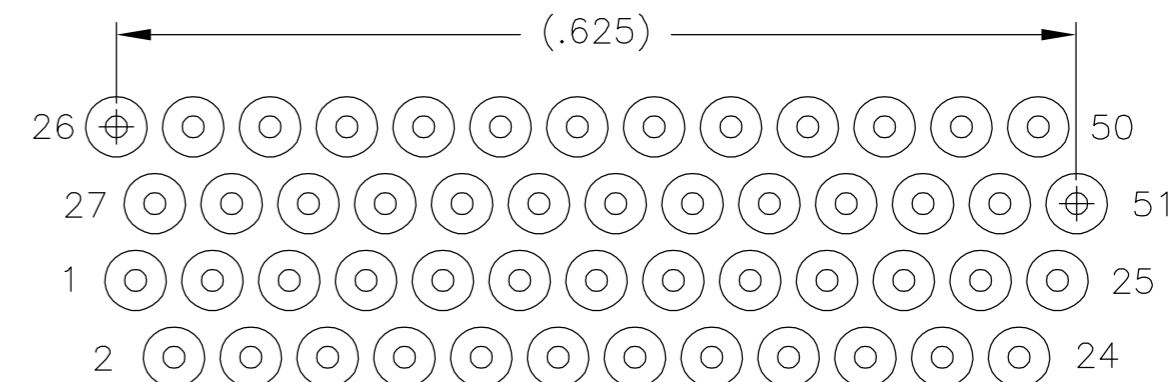

51 POSITION

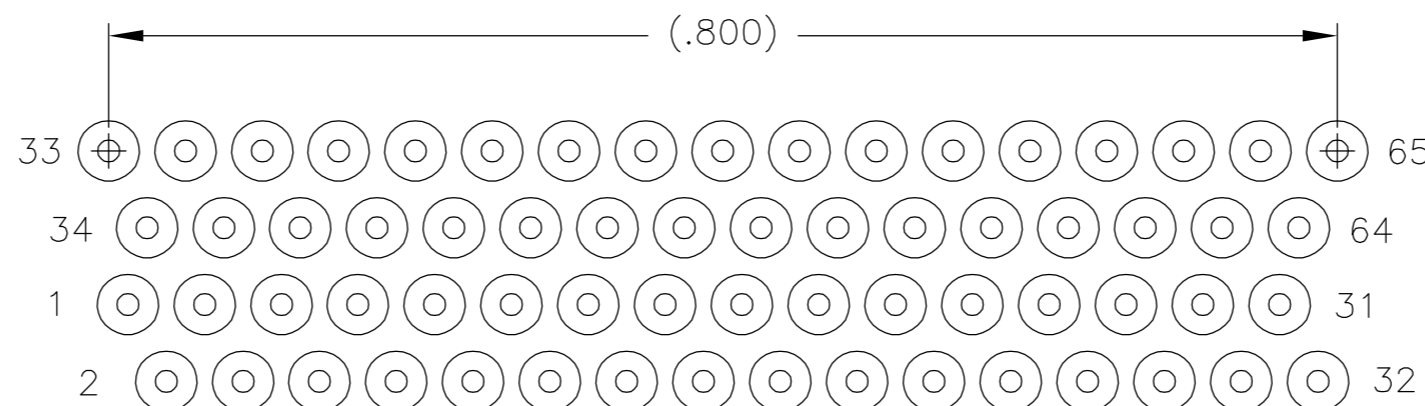

65 POSITION

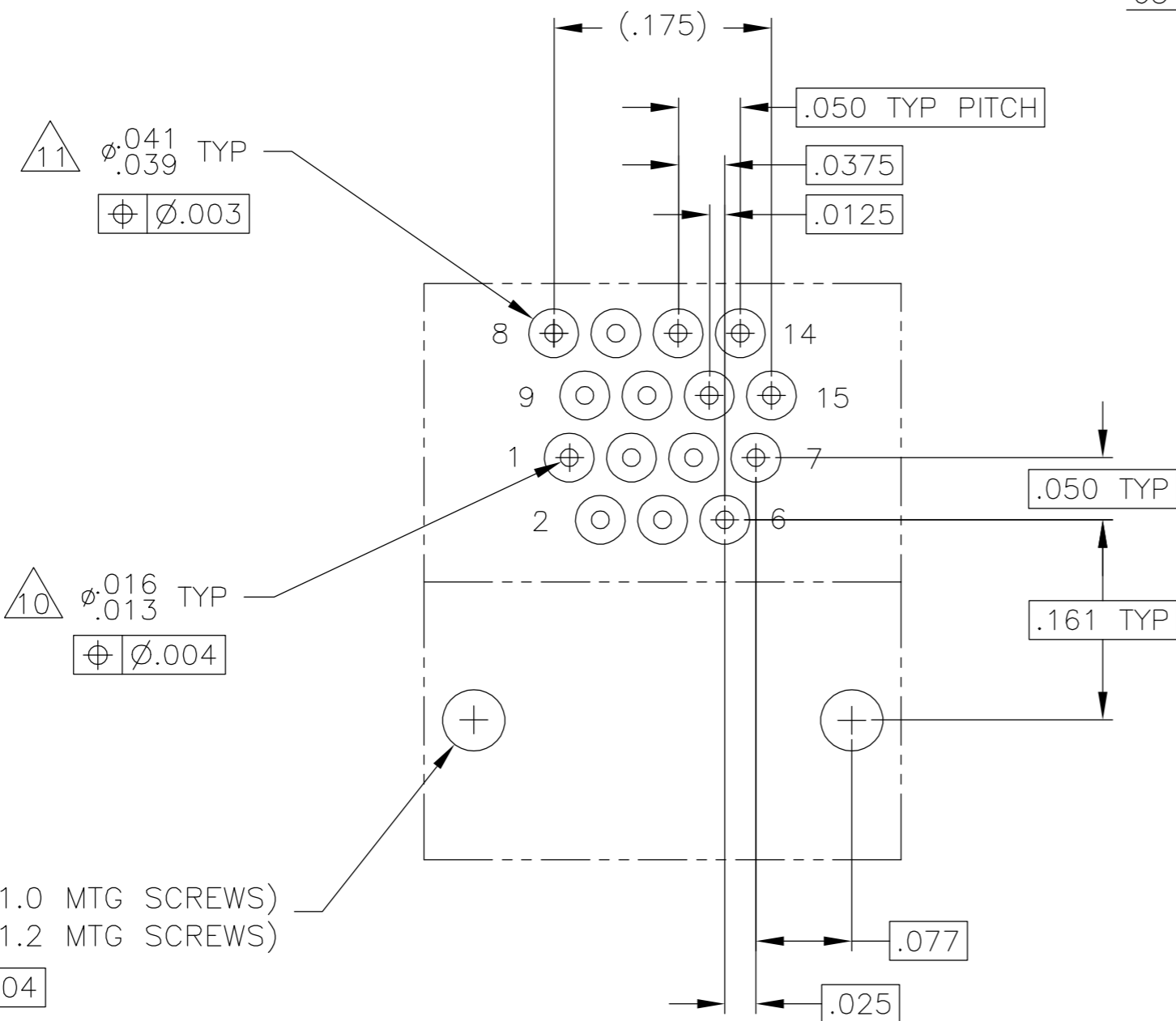

TYPICAL PCB LAYOUT $\Delta 9$
 SIZE 15 SHOWN FOR REFERENCE

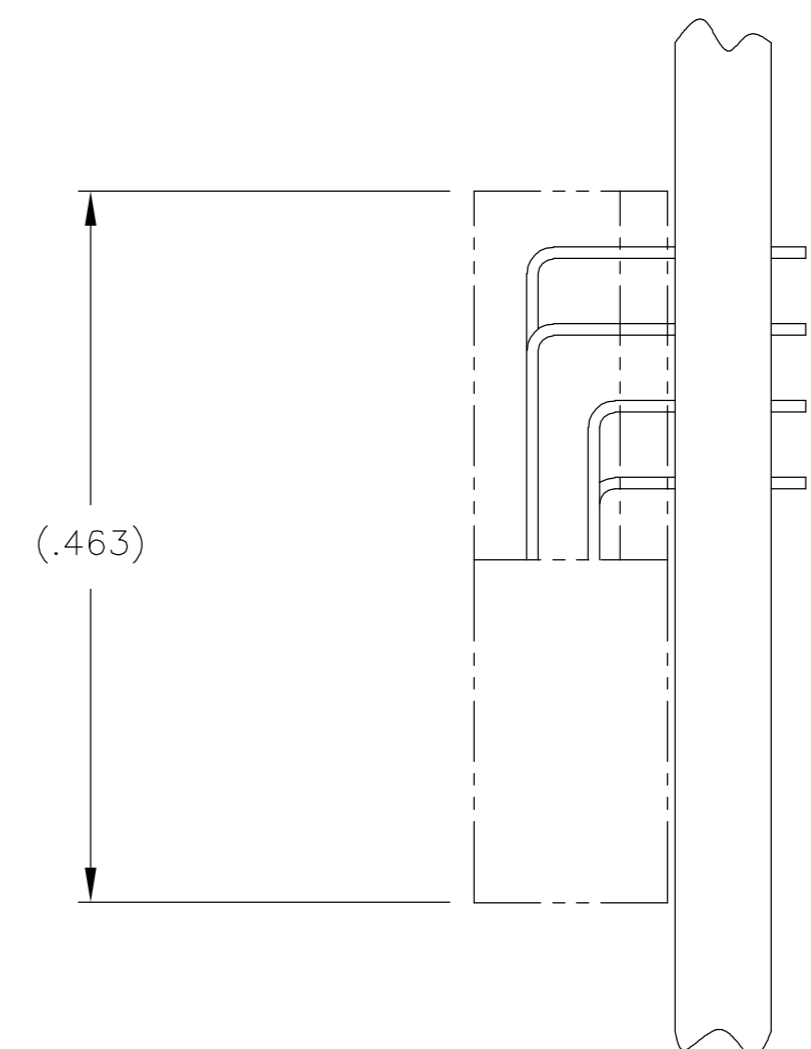

- $\Delta 9$ POSITIONAL TOLERANCES FOR BASIC DIMENSIONED FEATURES ARE RELATIVE TO FIDUCIALS OR SOME SIMILAR DATUM REFERENCES DEFINED BY PCB DESIGNER
- $\Delta 10$ PLATED THROUGH HOLES
- $\Delta 11$ SOLDER PADS
- 12 ALL THROUGH HOLE LAYOUTS ARE AS VIEWED FROM TOP OF PCB

THIS DRAWING IS A CONTROLLED DOCUMENT.		DWN M STORRY	31 AUG 00	Tyco Electronics Corporation Harrisburg, PA 17105-3608	
DIMENSIONS: INCHES	TOLERANCES UNLESS OTHERWISE SPECIFIED:	CHK -	APVD -	NAME	
	0 PLC ± -	PRODUCT SPEC		RECP ASSEMBLY, HORIZONTAL MOUNT, INVERTED, THROUGH HOLE, 2 TO 4 ROW, .050 SPACING, PLASTIC OR METAL,	
	1 PLC ± -	APPLICATION SPEC		SIZE CAGE CODE DRAWING NO RESTRICTED TO	
	2 PLC ± .010	-		A2 OPJN9 C=1589489	
	3 PLC ± .005	-		SCALE 8:1 SHEET 2 of 2 REV D1	
MATERIAL SEE NOTES	FINISH SEE NOTES	4 PLC ± -	WEIGHT -		
		ANGLES ± 1°	CUSTOMER DRAWING		