

NB7N017M

3.3V SiGe 8-Bit Dual Modulus Programmable Divider/Prescaler with CML Outputs

The NB7N017M is a high speed 8-bit dual modulus programmable divider/prescaler with 16 mA CML outputs capable of switching at input frequencies greater than 3.5 GHz. The CML output structure contains internal 50 Ω source termination resistor to V_{CC} . The device generates 400 mV output amplitude with 50 Ω receiver resistor to V_{CC} . This I/O structure enables easy implementation of the NB7N017M in 50 Ω systems.

The differential inputs contain 50 Ω termination resistors to VT pads and all differential inputs accept RSECL, ECL, LVDS, LVCMOS, LVTTTL, and CML.

Internally, the NB7N017M uses a > 3.5 GHz 8-bit programmable down counter. A select pin, SEL, is used to select between two words, Pa[0:7] and Pb[0:7], that are stored in REGa and REGb respectively. Two parallel load pins, PLa and PLb, are used to load the level triggered programming registers, REGa and REGb, respectively. A differential clock enable, CE, pin is available.

The NB7N017M offers a differential output, TC. Terminal count output, TC, goes high for one clock cycle when the counter has reached the all zeros state. To reduce output phase noise, TC is retimed with the rising edge triggered latches.

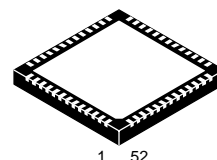
Features

- Maximum Input Clock Frequency > 3.5 GHz Typical
- Differential CLK Clock Input
- Differential CE Clock Enable Input
- Differential SEL Word Select Input
- 50 Ω Internal Input and Output Termination Resistors
- Differential TC Terminal Count Output
- All Outputs 16 mA CML with 50 Ω Internal Source Termination to V_{CC}
- All Single-Ended Control Pins CMOS and PECL/NECL Compatible
- Counter Programmed Using One of Two Single-Ended Words, Pa[0:7] and Pb[0:7], Stored in REGa and REGb
- REGa and REGb Implemented with Level Triggered Latch
- Compatible with Existing 3.3 V LVEP, EP, and SG Devices
- Ability to Program the Divider without Disturbing Current Settings
- Positive CML Output Operating Range: $V_{CC} = 3.0$ V to 3.465 V with $V_{EE} = 0$ V
- Negative CML Output Operating Range: $V_{CC} = 0$ V with $V_{EE} = -3.0$ V to -3.465 V
- V_{BB} Reference Voltage Output
- CML Output Level: 400 mV Peak-Peak Output with 50 Ω Receiver Resistor to V_{CC}
- Pb-Free Packages are Available*



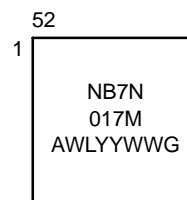
ON Semiconductor®

<http://onsemi.com>



QFN-52
MN SUFFIX
CASE 485M

MARKING DIAGRAM*



A = Assembly Site
WL = Wafer Lot
YY = Year
WW = Work Week
G = Pb-Free Package

*For additional marking information, refer to Application Note AND8002/D.

ORDERING INFORMATION

See detailed ordering and shipping information in the package dimensions section on page 18 of this data sheet.

*For additional information on our Pb-Free strategy and soldering details, please download the ON Semiconductor Soldering and Mounting Techniques Reference Manual, SOLDERRM/D.

NB7N017M

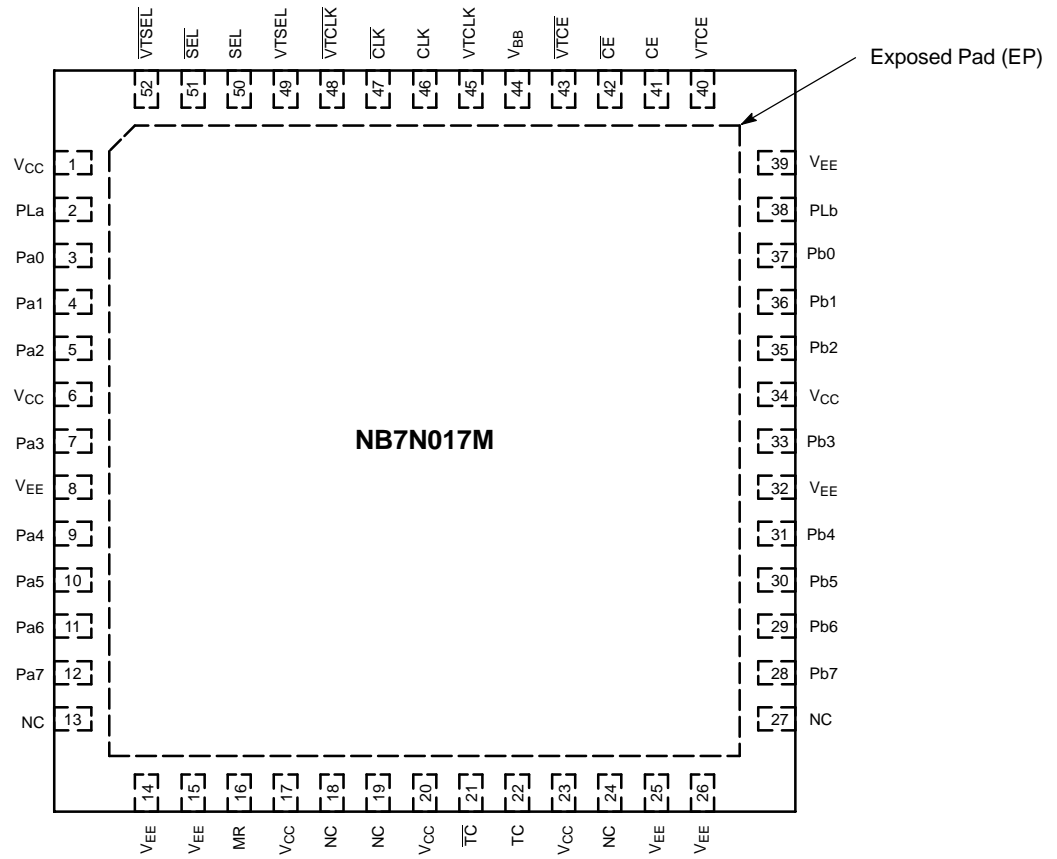


Figure 1. Pinout (Top View)

NB7N017M

Table 1. PIN DESCRIPTION

Pin Name	I/O	Default State	Single/Differential (Notes 1 and 2)	Description
CLK	ECL, CML, LVCMOS, LVDS, LVTTTL Input	–	Differential	Clock
CE	ECL, CML, LVCMOS, LVDS, LVTTTL Input	–	Differential	Clock Enable
MR	CMOS, ECL Input	Low	Single	Asynchronous Master Reset: Counter set to 0000 0000 to reload at next CLK pulse, REGa and REGb = 1111 1111 and TC = 1.
SEL	ECL, CML, LVCMOS, LVDS, LVTTTL Input	–	Differential	Divide Select
PLa, PLb	CMOS, ECL Input	Low	Single	Parallel Load Counter Latch from Pa[0:7], Pb[0:7] (Level Triggered)
TC	CML Output	–	Differential	Terminal Count, 16 mA CML output with 50 Ω Source Termination to V _{CC} (Note 5)
Pa[0:7], Pb[0:7]	CMOS, ECL Input	High	Single	Counter Program Pins. CMOS and PECL/NECL compatible Pa7 = MSB, Pb7 = MSB
V _{CC}	Power	–	–	Positive Supply
V _{EE}	Power	–	–	Negative Supply
VTCLK, $\overline{\text{VTCLK}}$, VTSEL, $\overline{\text{VTSEL}}$, VTCE, $\overline{\text{VTCE}}$	Termination	–	Differential	50 Ω Internal Input Termination Resistor (Note 6)
V _{BB}	Output	–	–	CMOS/ECL Reference Voltage Output
NC	N/A	–	–	No Connect (Note 4)
EP	–	–	–	Exposed Pad (Note 3)

1. All high speed inputs and outputs are differential to improve performance.
2. All single-ended inputs are CMOS and NECL/ECL compatible.
3. All V_{CC} and V_{EE} pins must be externally connected to external power supply voltage to guarantee proper device operation. The thermally exposed pad (EP) on package bottom (see case drawing) must be attached to a heat-sinking conduit. Exposed pad is bonded to the lowest voltage potential, V_{EE}.
4. The NC pins are electrically connected to the die and must be left open.
5. CML outputs require 50 Ω receiver termination resistor to V_{CC} for proper operation.
6. In the differential configuration when the input termination pins are connected to the common termination voltage, and if no signal is applied then the device will be susceptible to self-oscillation.

NB7N017M

Table 2. CE Truth Table

CE	Clock Status
LOW	Clock Disabled
HIGH	Clock Enabled

Table 3. SEL Truth Table

SEL	Active Register
LOW	REGa
HIGH	REGb

Table 4. Register Programming Values for Various Divide Ratios

Pa7/Pb7	Pa6/Pb6	Pa5/Pb5	Pa4/Pb4	Pa3/Pb3	Pa2/Pb2	Pa1/Pb1	Pa0/Pb0	Divide By
0	0	0	0	0	0	0	0	undefined
0	0	0	0	0	0	0	1	2
0	0	0	0	0	0	1	0	3
0	0	0	0	0	0	1	1	4
-	-	-	-	-	-	-	-	-
-	-	-	-	-	-	-	-	-
1	1	1	1	1	1	0	1	254
1	1	1	1	1	1	1	0	255
1	1	1	1	1	1	1	1	256

Table 5. Function Table

MR	Pla	PLb	SEL	CE	CLK	Function
H	X	X	X	X	X	Master Reset (Counter programmed to 0000 0000, REGa and REGb programmed to 1111 1111 and TC to 1)
L	H	L	X	X	X	REGa is transparent to Pa[0:7]
L	L	H	X	X	X	REGb is transparent Pb[0:7]
L	L	L	L	H	Z	Count; At TC pulse, load counter from REGa
L	L	L	H	H	Z	Count; At TC pulse, load counter from REGb
L	X	X	X	L	X	Hold

X – Don't Care

H – HIGH

L – LOW

Z – Rising Edge

NB7N017M

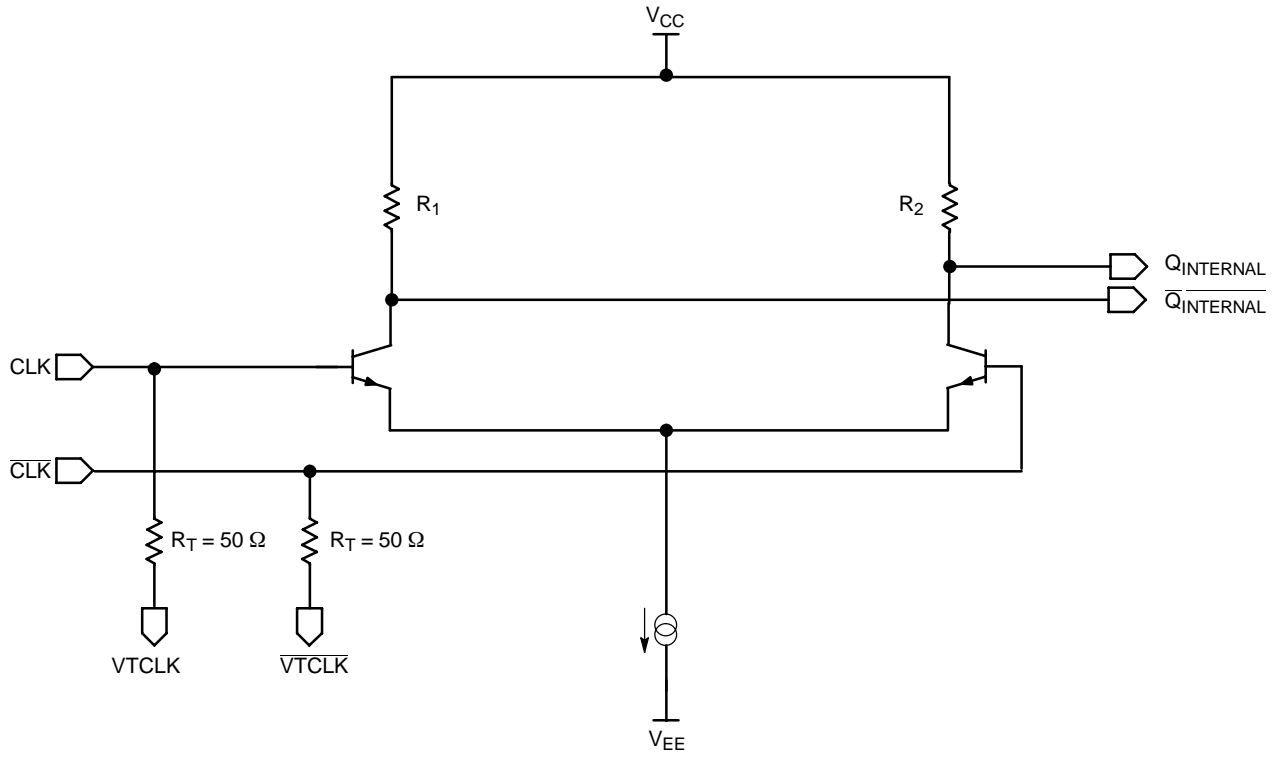


Figure 2. Input Structure

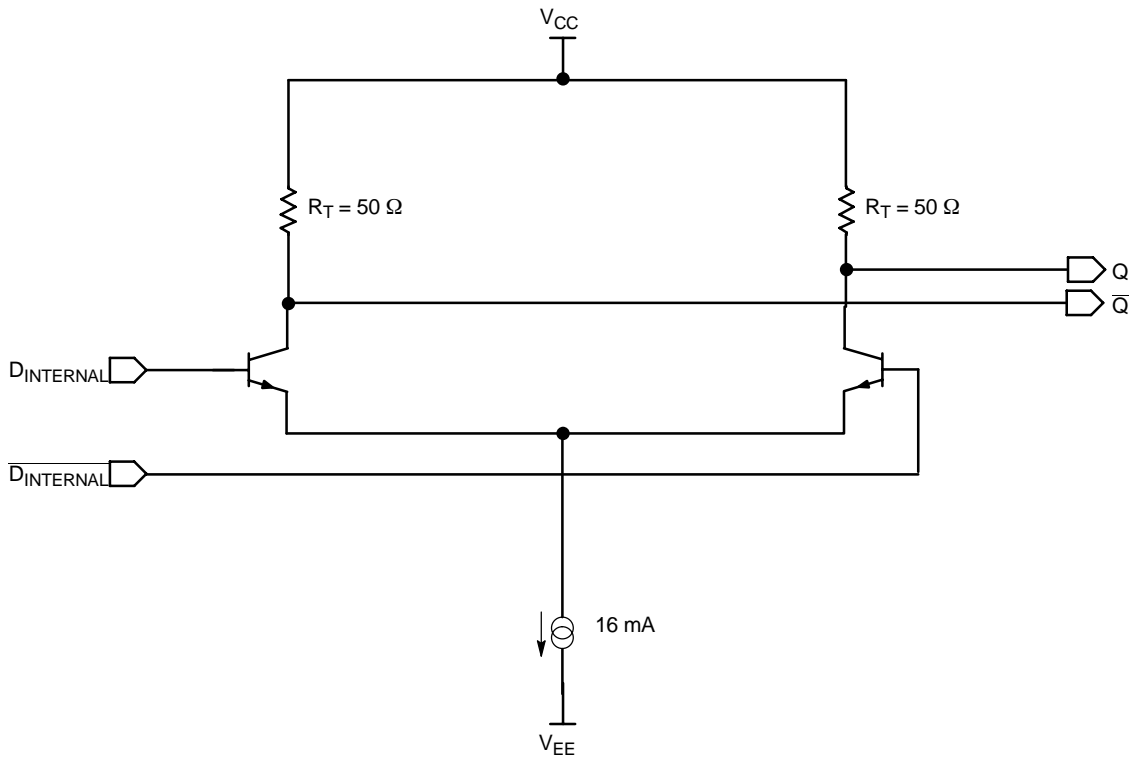


Figure 3. Output Structure

NB7N017M

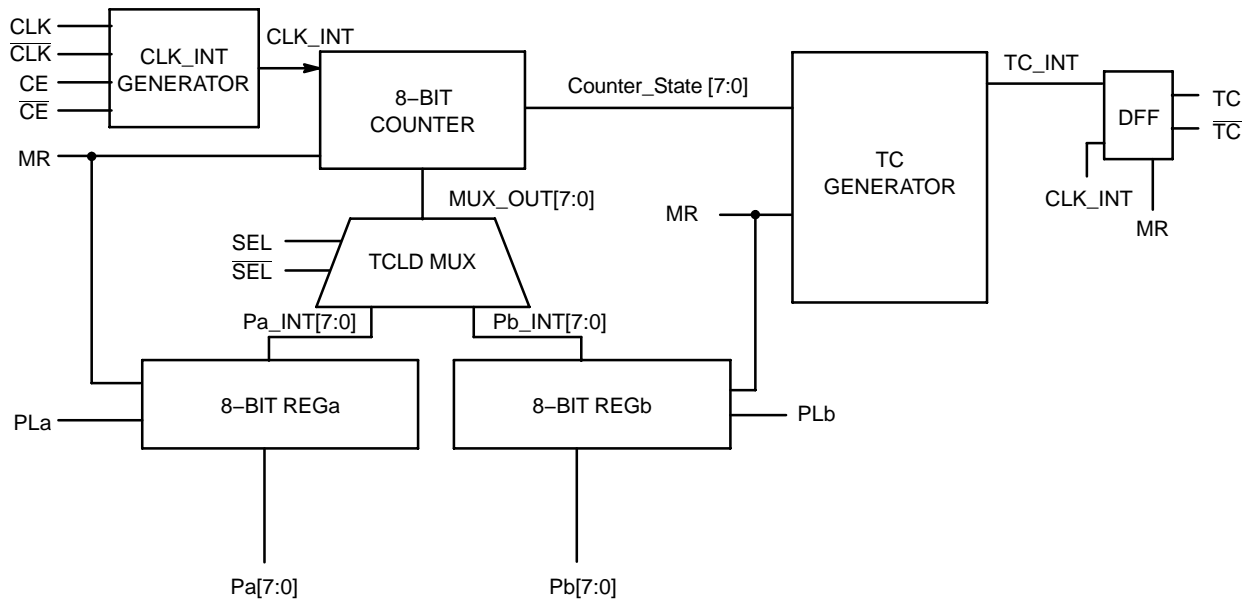


Figure 4. Block Diagram

Table 6. Interface Options

CLK INPUT interfacing options	CLK INPUT INTERFACING OPTIONS
CML	Connect VTCLK and \overline{VTCLK} to V_{CC}
LVDS	Connect VTCLK and \overline{VTCLK} together
AC-COUPLED	Bias VTCLK and \overline{VTCLK} Inputs within (VIHCMR) Common Mode Range
RSECL, PECL, NECL	Standard ECL Termination Techniques or connect VTCLK and \overline{VTCLK} to V_{TT}
LVTTL, LVCMOS	An Entered Voltage Should be Applied to the unused Complementary Differential Input. Nominal Voltage is 1.5 V for LVTTL and $V_{CC}/2$ for LVCMOS Inputs.

Table 7. ATTRIBUTES

Characteristic	Value	
Internal Input Pulldown Resistor (MR, PLa, PLb)	75 k to V_{EE}	
Internal Input Pullup Resistor (Pa[0:7], Pb[0:7])	75 k to V_{CC}	
ESD Protection	Human Body Model	>500 V
	Machine Model	>10 V
	Charged Device Model	>2 kV
Moisture Sensitivity (Note 7)	Pb Pkg	Pb-Free Pkg
	QFN-52	Level 2
Flammability Rating Oxygen Index: 28 to 34	UL 94 V-0 @ 0.125 in	
Transistor Count	1914	
Meets or exceeds JEDEC Spec EIA/JESD78 IC Latchup Test		

7. For additional information, see Application Note AND8003/D.

NB7N017M

Table 8. MAXIMUM RATINGS

Symbol	Parameter	Condition 1	Condition 2	Rating	Units
V_{CC}	Positive Power Supply	$V_{EE} = 0\text{ V}$		3.6	V
V_{EE}	Negative Power Supply	$V_{CC} = 0\text{ V}$		-3.6	V
V_I	Positive Input Negative Input	$V_{EE} = 0\text{ V}$ $V_{CC} = 0\text{ V}$	$V_I \leq V_{CC}$ $V_I \geq V_{EE}$	3.6 -3.6	V V
V_{INPP}	Differential Input Voltage $ \text{CLK} - \overline{\text{CLK}} $	$V_{CC} - V_{EE} \geq 2.8\text{ V}$		2.8 V	V
I_{in}	Input Current through R_T (50 Ω Resistor)	Continuous Surge		25 50	mA mA
I_{out}	Output Current	Continuous Surge		25 50	mA mA
I_{BB}	V_{BB} Sink/Source			± 0.5	mA
T_A	Operating Temperature Range			-40 to +85	$^{\circ}\text{C}$
T_{stg}	Storage Temperature Range			-65 to +150	$^{\circ}\text{C}$
θ_{JA}	Thermal Resistance (Junction-to-Ambient) (Note 8)	0 lfpm 500 lfpm	52 QFN 52 QFN	25 – 32 20 – 27	$^{\circ}\text{C}/\text{W}$ $^{\circ}\text{C}/\text{W}$
θ_{JC}	Thermal Resistance (Junction-to-Case)	2S2P (Note 8)	52 QFN	4 – 15	$^{\circ}\text{C}/\text{W}$
T_{sol}	Wave Solder Pb Pb-Free			265 265	$^{\circ}\text{C}$

Maximum ratings are those values beyond which device damage can occur. Maximum ratings applied to the device are individual stress limit values (not normal operating conditions) and are not valid simultaneously. If these limits are exceeded, device functional operation is not implied, damage may occur and reliability may be affected.

8. JEDEC standard multilayer board – 2S2P (2 signal, 2 power).

NB7N017M

Table 9. DC CHARACTERISTICS, POSITIVE CML OUTPUT $V_{CC} = 3.0\text{ V to }3.465\text{ V}$; $V_{EE} = 0\text{ V}$ (Note 11)

Symbol	Characteristic	-40°C			25°C			85°C			Unit
		Min	Typ	Max	Min	Typ	Max	Min	Typ	Max	
I_{CC}	Positive Power Supply Current	170	200	230	170	200	230	170	200	230	mA
V_{OH}	Output HIGH Voltage (Note 12)	$V_{CC} - 40$	$V_{CC} - 10$	V_{CC}	$V_{CC} - 40$	$V_{CC} - 10$	V_{CC}	$V_{CC} - 40$	$V_{CC} - 10$	V_{CC}	mV
V_{OL}	Output LOW Voltage (Note 12)		$V_{CC} - 400$	$V_{CC} - 330$		$V_{CC} - 400$	$V_{CC} - 330$		$V_{CC} - 400$	$V_{CC} - 330$	mV

DIFFERENTIAL INPUT DRIVEN SINGLE-ENDED (Figures 19, 21)

V_{th}	Input Threshold Reference Voltage Range (Note 9)	$V_{EE} + 1125$		$V_{CC} - 75$	$V_{EE} + 1125$		$V_{CC} - 75$	$V_{EE} + 1125$		$V_{CC} - 75$	mV
V_{IH}	Single-Ended Input HIGH Voltage	$V_{th} + 75$		V_{CC}	$V_{th} + 75$		V_{CC}	$V_{th} + 75$		V_{CC}	mV
V_{IL}	Single-Ended Input LOW Voltage	V_{EE}		$V_{th} - 75$	V_{EE}		$V_{th} - 75$	V_{EE}		$V_{th} - 75$	mV

DIFFERENTIAL INPUTS DRIVEN DIFFERENTIALLY (Figures 20, 22)

V_{IHD}	Differential Input HIGH Voltage	$V_{EE} + 1200$		V_{CC}	$V_{EE} + 1200$		V_{CC}	$V_{EE} + 1200$		V_{CC}	mV
V_{ILD}	Differential Input LOW Voltage	V_{EE}		$V_{CC} - 75$	V_{EE}		$V_{CC} - 75$	V_{EE}		$V_{CC} - 75$	mV
V_{CMR}	Input Common Mode Range (Differential Cross-Point Voltage) (Note 10)	$V_{EE} + 1200$		$V_{CC} - 50$	$V_{EE} + 1200$		$V_{CC} - 50$	$V_{EE} + 1200$		$V_{CC} - 50$	mV
V_{ID}	Differential Input Voltage	$V_{EE} + 100$		V_{CC}	$V_{EE} + 100$		V_{CC}	$V_{EE} + 100$		V_{CC}	mV
V_{BB}	Output Voltage Reference @ -100 μA	1840	1970	2100	1840	1960	2100	1820	1970	2100	mV
R_{TIN}	Internal Input Termination Resistor	45	50	55	45	50	55	45	50	55	Ω
R_{TOUT}	Internal Output Resistor	45	50	55	45	50	55	45	50	55	Ω
I_{IH}	Input HIGH Current CLK, CE, SEL MR, PLa, PLb Pa[0:7], Pb[0:7]	0 0 -50	7 30 -10	15 60 0	0 0 -50	7 30 -10	15 60 0	0 0 -50	7 30 -10	15 60 0	μA
I_{IL}	Input LOW Current CLK, CE, SEL MR, PLa, PLb Pa[0:7], Pb[0:7]	-0.5 0 -50	 20 -20	0.5 60 0	-0.5 0 -50	 20 -20	0.5 60 0	-0.5 0 -50	 20 -20	0.5 60 0	μA

NOTE: Device will meet the specifications after thermal equilibrium has been established when mounted in a test socket or printed circuit board with maintained airflow greater than 500 lfm. Electrical parameters are guaranteed only over the declared operating temperature range. Functional operation of the device exceeding these conditions is not implied. Device specification limit values are applied individually under normal operating conditions and not valid simultaneously.

9. V_{th} is applied to the complementary input when operating in single-ended mode.

10. V_{CMR} minimum varies 1:1 with V_{EE} , V_{CMR} maximum varies 1:1 with V_{CC} . The V_{CMR} range is referenced to the most positive side of the differential input signal.

11. Input and output parameters vary 1:1 with V_{CC} . V_{EE} can vary +0.925 V to -0.165 V.

12. All loading with 50 Ω to V_{CC} .

13. V_{IHCMR} min varies 1:1 with V_{EE} , V_{IHCMR} max varies 1:1 with V_{CC} . The V_{IHCMR} range is referenced to the most positive side of the differential input signal.

NB7N017M

Table 10. DC CHARACTERISTICS, NEGATIVE CML OUTPUT $V_{CC} = 0\text{ V}$; $V_{EE} = -3.465\text{ V to }-3.0\text{ V}$ (Note 16)

Symbol	Characteristic	-40°C			25°C			85°C			Unit
		Min	Typ	Max	Min	Typ	Max	Min	Typ	Max	
I_{CC}	Positive Power Supply Current	170	200	230	170	200	230	170	200	230	mA
V_{OH}	Output HIGH Voltage (Note 17)	V_{CC} -40	V_{CC} -10	V_{CC}	V_{CC} -40	V_{CC} -10	V_{CC}	V_{CC} -40	V_{CC} -10	V_{CC}	mV
V_{OL}	Output LOW Voltage (Note 17)		V_{CC} -400	V_{CC} -330		V_{CC} -400	V_{CC} -330		V_{CC} -400	V_{CC} -330	mV

DIFFERENTIAL INPUT DRIVEN SINGLE-ENDED (Figures 19, 21)

V_{th}	Input Threshold Reference Voltage Range (Note 14)	V_{EE} +1125		V_{CC} -75	V_{EE} +1125		V_{CC} -75	V_{EE} +1125		V_{CC} -75	mV
V_{IH}	Single-Ended Input HIGH Voltage	V_{th} +75		V_{CC}	V_{th} +75		V_{CC}	V_{th} +75		V_{CC}	mV
V_{IL}	Single-Ended Input LOW Voltage	V_{EE}		V_{th} -75	V_{EE}		V_{th} -75	V_{EE}		V_{th} -75	mV

DIFFERENTIAL INPUTS DRIVEN DIFFERENTIALLY (Figures 20, 22)

V_{IHD}	Differential Input HIGH Voltage	V_{EE} +1200		V_{CC}	V_{EE} +1200		V_{CC}	V_{EE} +1200		V_{CC}	mV
V_{ILD}	Differential Input LOW Voltage	V_{EE}		V_{CC} -75	V_{EE}		V_{CC} -75	V_{EE}		V_{CC} -75	mV
V_{CMR}	Input Common Mode Range (Differential Cross-Point Voltage) (Note 15)	V_{EE} +1200		V_{CC} -50	V_{EE} +1200		V_{CC} -50	V_{EE} +1200		V_{CC} -50	mV
V_{ID}	Differential Input Voltage	V_{EE} +100		V_{CC}	V_{EE} +100		V_{CC}	V_{EE} +100		V_{CC}	mV
V_{BB}	Output Voltage Reference @ -100 μA	-1460	-1330	-1200	-1460	-1330	-1200	-1460	-1330	-1200	mV
R_{TIN}	Internal Input Termination Resistor	45	50	55	45	50	55	45	50	55	Ω
R_{TOUT}	Internal Output Resistor	45	50	55	45	50	55	45	50	55	Ω
I_{IH}	Input HIGH Current CLK, CE, SEL MR, PLa, PLb Pa[0:7], Pb[0:7]	0 0 -50	7 30 -10	15 60 0	0 0 -50	7 30 -10	15 60 0	0 0 -50	7 30 -10	15 60 0	μA
I_{IL}	Input LOW Current CLK, CE, SEL MR, PLa, PLb Pa[0:7], Pb[0:7]	-0.5 0 -50	0 20 -20	0.5 60 0	-0.5 0 -50	0 20 -20	0.5 60 0	-0.5 0 -50	0 20 -20	0.5 60 0	μA

NOTE: Device will meet the specifications after thermal equilibrium has been established when mounted in a test socket or printed circuit board with maintained airflow greater than 500 lfm. Electrical parameters are guaranteed only over the declared operating temperature range. Functional operation of the device exceeding these conditions is not implied. Device specification limit values are applied individually under normal operating conditions and not valid simultaneously.

14. V_{th} is applied to the complementary input when operating in single-ended mode.

15. V_{CMR} minimum varies 1:1 with V_{EE} , V_{CMR} maximum varies 1:1 with V_{CC} . The V_{CMR} range is referenced to the most positive side of the differential input signal.

16. Input and output parameters vary 1:1 with V_{CC} .

17. All loading with 50 Ω to V_{CC} .

18. V_{IHCMR} min varies 1:1 with V_{EE} , V_{IHCMR} max varies 1:1 with V_{CC} . The V_{IHCMR} range is referenced to the most positive side of the differential input signal.

NB7N017M

Table 11. AC CHARACTERISTICS $V_{CC} = 0\text{ V}$; $V_{EE} = -3.465\text{ V to } -3.0\text{ V}$ or $V_{CC} = 3.0\text{ V to } 3.465\text{ V}$; $V_{EE} = 0\text{ V}$ (Note 19)

Symbol	Characteristic	-40°C			25°C			85°C			Unit
		Min	Typ	Max	Min	Typ	Max	Min	Typ	Max	
V_{OUTPP}	Output Voltage Amplitude @ ÷ 2 Mode $f_{in} = 3.5\text{ GHz}$ (See Figure 5)	300	400		300	400		300	400		mV
t_{PLH} , t_{PHL}	Propagation Delay to Output Differential CLK to TC MR to TC	435 100		555 500	455 100		575 500	475 100		595 500	ps
t_{JITTER}	RMS Random Clock Jitter $f_{in} = 3.5\text{ GHz}$ (See Figure 5)			2.5			3.0			3.0	ps
V_{INPP}	Input Voltage Swing/Sensitivity (Differential Configuration) (Note 20)	100		2500	100		2500	100		2500	mV
t_r , t_f	Output Rise/Fall Times (20% – 80%)	25	45	65	25	45	65	25	45	65	ps
t_s	Setup Time (Figure 23)	Pa[7:0] to PLa Pb[7:0] to PLb CE to CLK SEL to CLK PLa to CLK PLb to CLK Pa[7:0] to CLK Pb[7:0] to CLK	3750 4500 400 300 2500 3250 4750 3000	2500 2000 30 120 2000 2750 3500 2500		3750 4500 400 300 2500 3250 4750 3000	2500 2000 30 120 2000 2750 3500 2500	3750 4500 400 300 2500 3250 4750 3000	2500 2000 30 120 2000 2750 3500 2500		ps
t_H	Hold Time (Figure 23)	PLa to Pa[7:0] PLb to Pb[7:0] CLK to CE CLK to SEL CLK to PLa CLK to PLb CLK to PLb[7:0] CLK to PLb[7:0]	-1500 -1250 450 0 -1750 -2250 -2250 -2000	-2700 -1900 40 -110 -1900 -2700 -3200 -2500		-1500 -1250 450 0 -1750 -2250 -2250 -2000	-2700 -1900 40 -110 -1900 -2700 -3200 -2500	-1500 -1250 450 0 -1750 -2250 -2250 -2000	-2700 -1900 40 -110 -1900 -2700 -3200 -2500		ps
t_{SKEW}	Device-to-Device (Note 21)		40	75		40	75		40	75	ps
t_{PW}	Minimum Pulse Width	MR	250	85		250	85		250	85	ps
t_{RR}	Reset Recovery	MR to CLK/ $\overline{\text{CLK}}$	3000	2500		3000	2500		3000	2500	ps

NOTE: Device will meet the specifications after thermal equilibrium has been established when mounted in a test socket or printed circuit board with maintained transverse airflow greater than 500 lfm. Electrical parameters are guaranteed only over the declared operating temperature range. Functional operation of the device exceeding these conditions is not implied. Device specification limit values are applied individually under normal operating conditions and not valid simultaneously.

19. Measured using a 400 mV source, 50% duty cycle clock source at $f_{in} = 1\text{ GHz}$ unless stated otherwise. All loading with $50\ \Omega$ to V_{CC} . Input edge rates 40 ps (20% – 80%).

20. V_{INPP} (MAX) cannot exceed $V_{CC} - V_{EE}$.

21. Device-to-Device skew for identical transitions at identical V_{CC} levels.

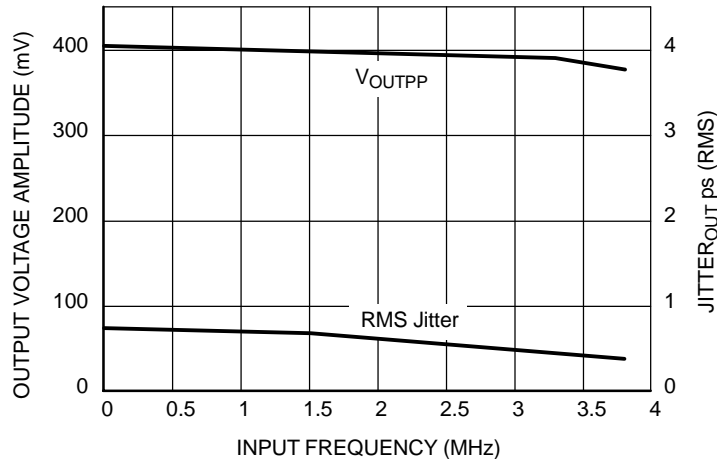


Figure 5. Output Voltage Amplitude (V_{OUTPP}) / RMS Jitter vs. Input Frequency (f_{in}) @ Ambient Temperature (Typical)

NB7N017M

Application Information

All NB7N017M inputs can accept PECL, CML, LVTTTL, LVCMOS and LVDS signal levels. The limitations for differential input signal (LVDS, PECL, or CML) are

minimum input swing of 100 mV and the maximum input swing of 450 mV. Within these conditions, the input voltage can range from V_{CC} to 1.2 V. Examples interfaces are illustrated below in a 50 Ω environment ($Z = 50 \Omega$).

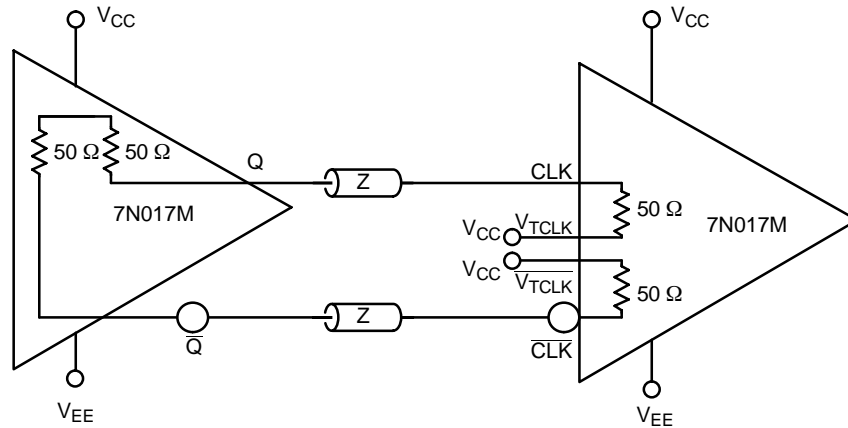


Figure 6. CML to CML Interface

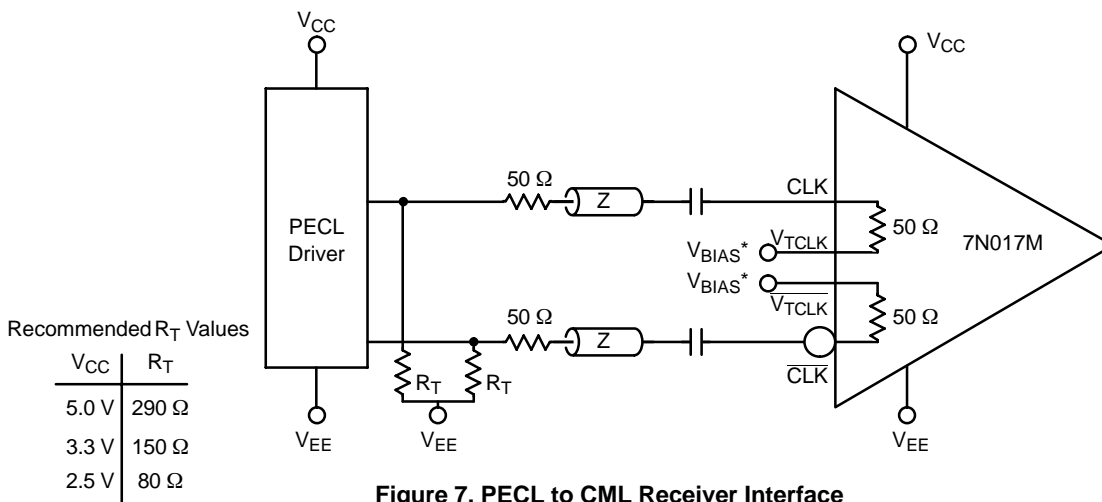


Figure 7. PECL to CML Receiver Interface

* V_{BIAS} is within V_{CMR} Range.

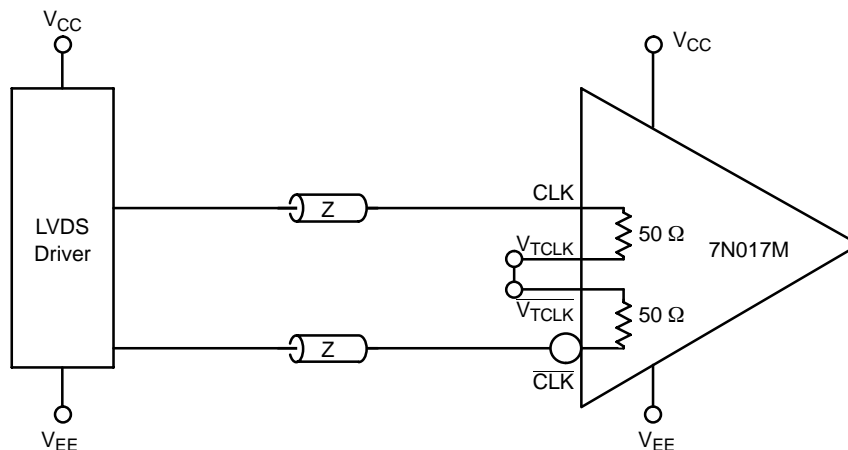


Figure 8. LVDS to CML Receiver Interface

NB7N017M

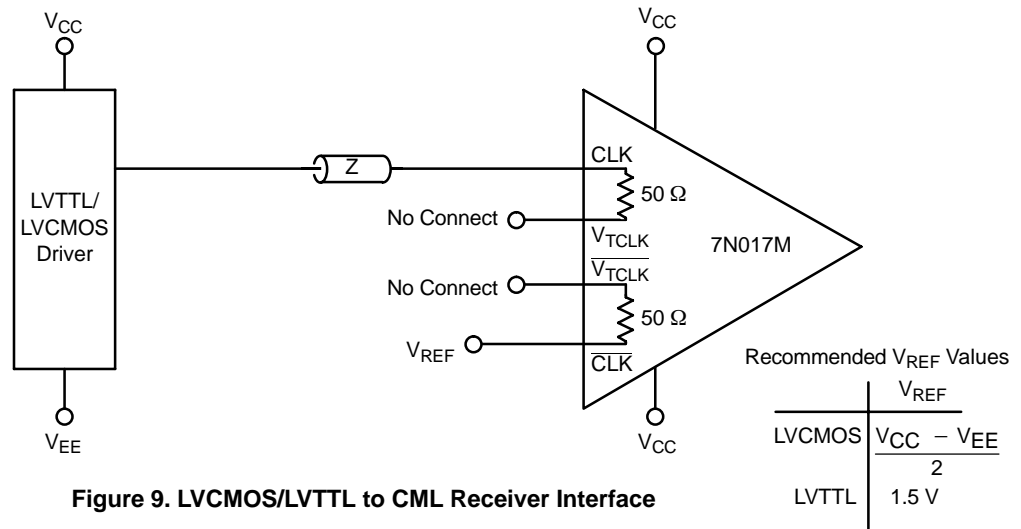


Table 12. OPERATION TABLE

MR	Pa	PLa	Pb	PLb	SEL	CE	CLK	CLK_INT	TC_INT	TC
1	XXXXXXXX	x	XXXXXXXX	X	X	X	X	X	X	X
0	00000101	H	00000100	H	X	H	L	H	H	H
0	00000101	H	00000100	H	X	H	L	H	X	X
0	XXXXXXXX	L	XXXXXXXX	L	L	H	H	H	X	X
0	XXXXXXXX	L	XXXXXXXX	L	X	H	L	L	X	X
0	XXXXXXXX	L	XXXXXXXX	L	X	H	H	H	X	X
0	XXXXXXXX	L	XXXXXXXX	L	X	H	L	L	X	X
0	XXXXXXXX	L	XXXXXXXX	L	X	H	H	H	X	X
0	XXXXXXXX	L	XXXXXXXX	L	X	H	L	L	X	X
0	XXXXXXXX	L	XXXXXXXX	L	X	H	H	H	X	X
0	XXXXXXXX	L	XXXXXXXX	L	X	H	L	L	X	X
0	XXXXXXXX	L	XXXXXXXX	L	X	H	H	H	X	X
0	XXXXXXXX	L	XXXXXXXX	L	X	H	L	L	X	X
0	XXXXXXXX	L	XXXXXXXX	L	X	H	H	H	X	X
0	XXXXXXXX	L	XXXXXXXX	L	X	H	L	L	X	X
0	XXXXXXXX	L	XXXXXXXX	L	X	H	H	H	X	X
0	XXXXXXXX	L	XXXXXXXX	L	X	H	L	L	X	X
0	XXXXXXXX	L	XXXXXXXX	L	X	H	H	H	X	X
0	XXXXXXXX	L	XXXXXXXX	L	X	H	L	L	X	X
0	XXXXXXXX	L	XXXXXXXX	L	X	H	H	H	X	X
0	XXXXXXXX	L	XXXXXXXX	L	X	H	L	L	X	X
0	XXXXXXXX	L	XXXXXXXX	L	X	H	H	H	X	X
0	XXXXXXXX	L	XXXXXXXX	L	X	H	L	L	X	X
0	XXXXXXXX	L	XXXXXXXX	L	X	H	H	H	X	X
0	XXXXXXXX	L	XXXXXXXX	L	X	H	L	L	X	X
0	XXXXXXXX	L	XXXXXXXX	L	X	H	H	H	X	X
0	XXXXXXXX	L	XXXXXXXX	L	X	H	L	L	X	X
0	XXXXXXXX	L	XXXXXXXX	L	X	H	L	L	X	X

X – Don't Care
H – HIGH
L – LOW

NB7N017M

Table 12. OPERATION TABLE

MR	Pa	PLa	Pb	PLb	SEL	CE	CLK	CLK_INT	TC_INT	TC
0	XXXXXXXX	L	XXXXXXXX	L	H	H	H	H	X	X
0	XXXXXXXX	L	XXXXXXXX	L	X	H	L	L	X	X
0	XXXXXXXX	L	XXXXXXXX	L	X	H	H	H	X	X
0	XXXXXXXX	L	XXXXXXXX	L	X	H	L	L	X	X
0	XXXXXXXX	L	XXXXXXXX	L	X	H	H	H	X	X
0	XXXXXXXX	L	XXXXXXXX	L	X	H	L	L	X	X
0	XXXXXXXX	L	XXXXXXXX	L	X	H	H	H	X	X
0	XXXXXXXX	L	XXXXXXXX	L	X	H	L	L	X	X
0	XXXXXXXX	L	XXXXXXXX	L	X	H	L	L	X	X
0	XXXXXXXX	L	XXXXXXXX	L	X	H	H	H	X	X
0	XXXXXXXX	L	XXXXXXXX	L	X	H	L	L	X	X
0	XXXXXXXX	L	XXXXXXXX	L	X	H	H	H	X	X
0	XXXXXXXX	L	XXXXXXXX	L	X	H	L	L	X	X
0	XXXXXXXX	L	XXXXXXXX	L	X	H	H	H	X	X
0	XXXXXXXX	L	XXXXXXXX	L	X	H	L	L	X	X
0	XXXXXXXX	L	XXXXXXXX	L	X	L	H	H	X	X
0	XXXXXXXX	L	XXXXXXXX	L	X	H	L	H	X	X
0	XXXXXXXX	L	XXXXXXXX	L	X	H	H	H	X	X
0	XXXXXXXX	L	XXXXXXXX	L	X	L	L	L	X	X
0	0000010	H	XXXXXXXX	L	X	H	H	H	X	X
0	XXXXXXXX	L	00000001	H	X	H	L	L	X	X
0	XXXXXXXX	L	XXXXXXXX	L	H	H	H	H	X	X
0	XXXXXXXX	L	XXXXXXXX	L	X	H	L	L	X	X
0	XXXXXXXX	L	XXXXXXXX	L	X	H	H	H	X	X
0	XXXXXXXX	L	XXXXXXXX	L	X	H	L	L	X	X
0	XXXXXXXX	L	XXXXXXXX	L	L	H	H	H	X	X
0	XXXXXXXX	L	XXXXXXXX	L	X	H	L	L	X	X
0	XXXXXXXX	L	XXXXXXXX	L	X	H	H	H	X	X
0	XXXXXXXX	L	XXXXXXXX	L	X	H	L	L	X	X
0	XXXXXXXX	L	XXXXXXXX	L	L	H	H	H	X	X
0	XXXXXXXX	L	XXXXXXXX	L	X	H	L	L	X	X
0	XXXXXXXX	L	XXXXXXXX	L	X	H	H	H	X	X
0	XXXXXXXX	L	XXXXXXXX	L	L	H	L	L	X	X
0	XXXXXXXX	L	XXXXXXXX	L	L	H	H	H	X	X
0	XXXXXXXX	L	XXXXXXXX	L	X	H	L	L	X	X
0	XXXXXXXX	L	XXXXXXXX	L	X	H	H	H	X	X
0	XXXXXXXX	L	XXXXXXXX	L	L	H	L	L	X	X
0	XXXXXXXX	L	XXXXXXXX	L	L	H	H	H	X	X
0	XXXXXXXX	L	XXXXXXXX	L	X	H	L	L	X	X
0	XXXXXXXX	L	XXXXXXXX	L	X	H	H	H	X	X

X – Don't Care
H – HIGH
L – LOW

NB7N017M

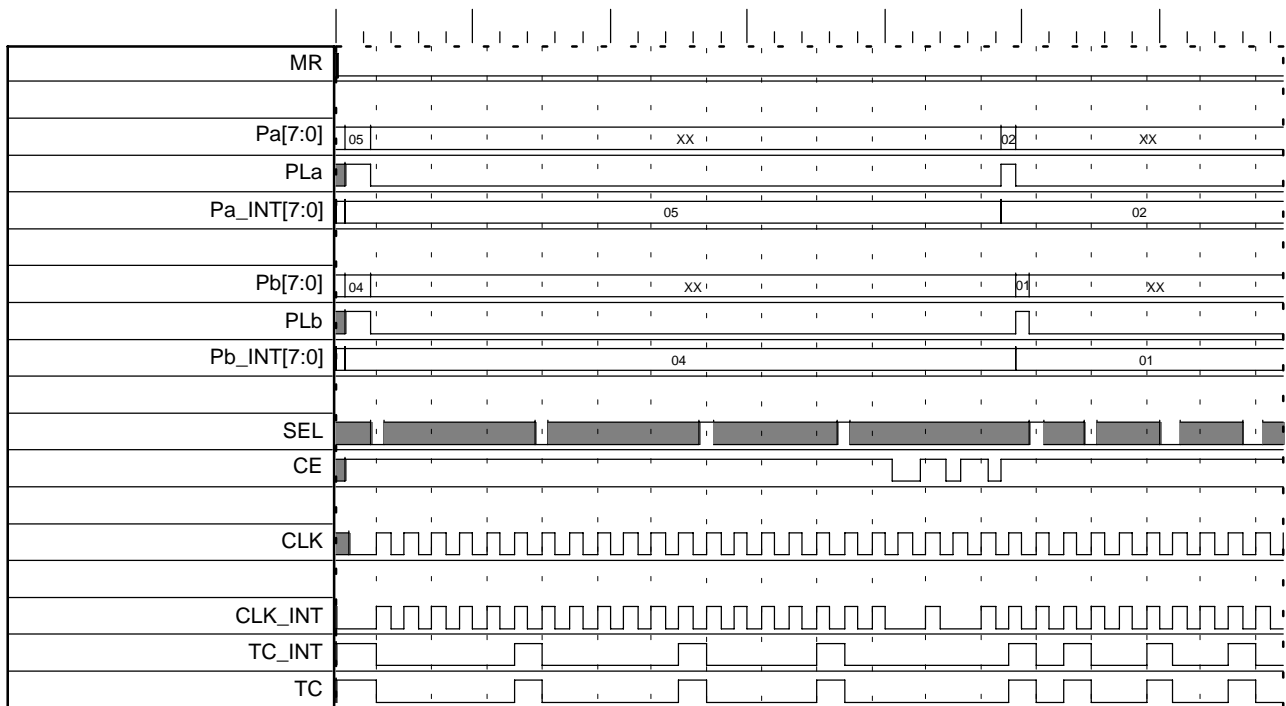


Figure 10. Device Timing Diagram for Table 12

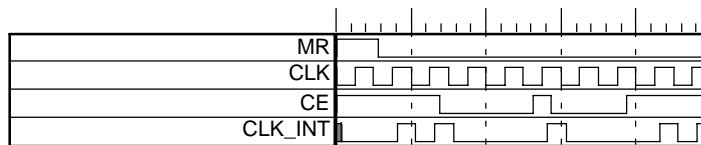
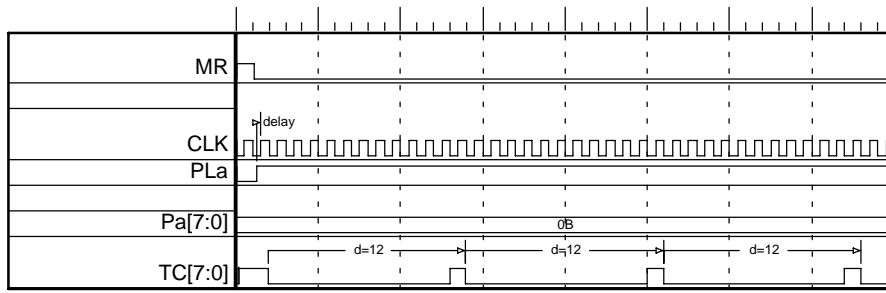
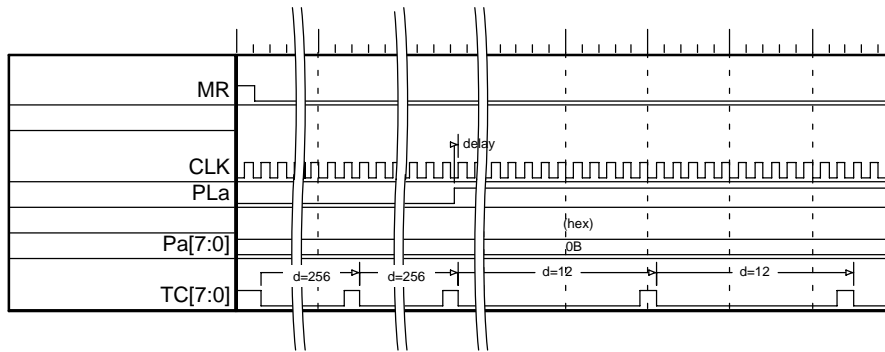


Figure 11. Timing Diagram for CE Input

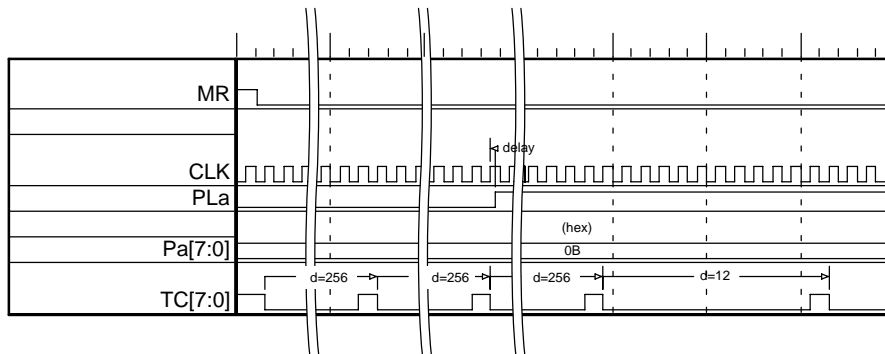
NB7N017M



**Figure 12. Timing Diagram for PLa / PLb Inputs
(SEL is Low)**

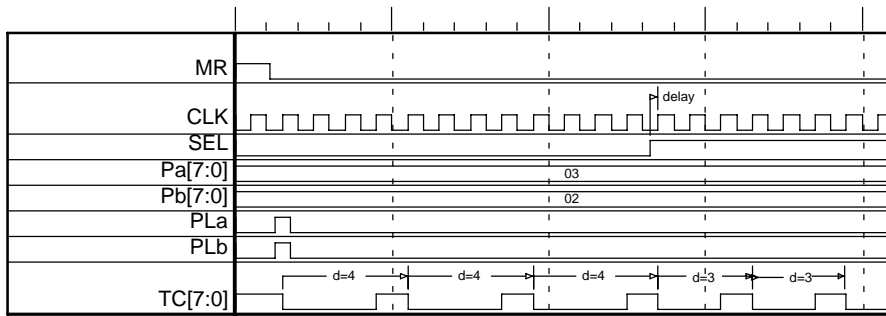


**Figure 13. Timing Diagram for PLa / PLb Inputs
(Before Critical Rising Edge of CLK)
(SEL is Low)**

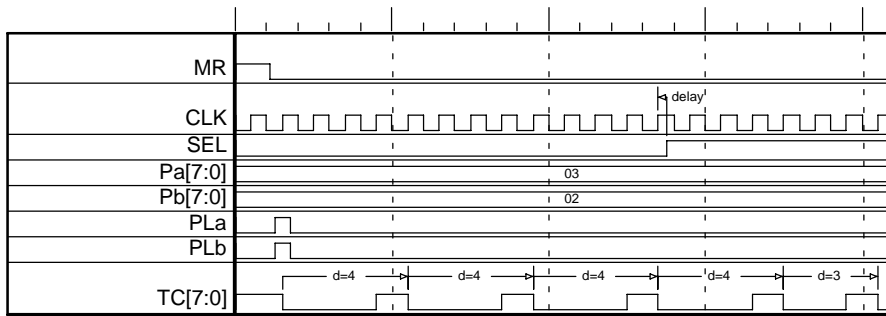


**Figure 14. Timing Diagram for PLa / PLb Inputs
(After Critical Rising Edge of CLK)
(SEL is Low)**

NB7N017M



**Figure 15. Timing Diagram for SEL Input
(Before Critical Rising Edge of CLK)**



**Figure 16. Timing Diagram for SEL Input
(After Critical Rising Edge of CLK)**

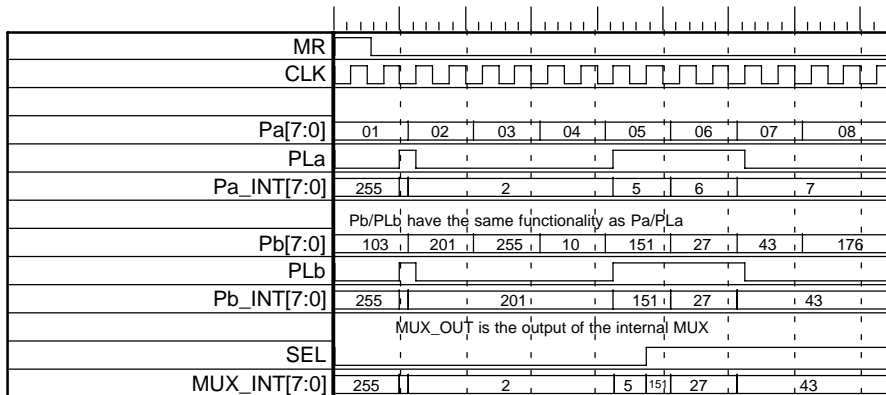


Figure 17. Timing Diagram Relating PLa, PLb, Pa(0:7), Pb(0:7)

NB7N017M

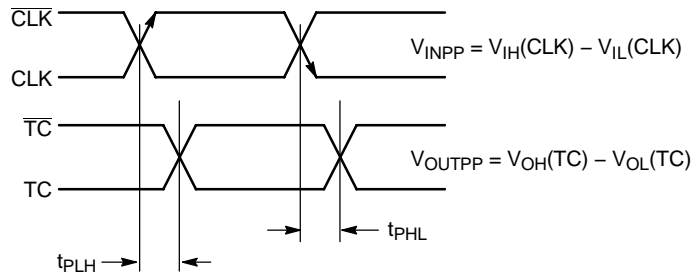


Figure 18. AC Reference Measurement

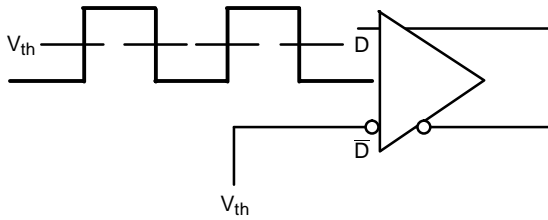


Figure 19. Differential Input Driven Single-Ended

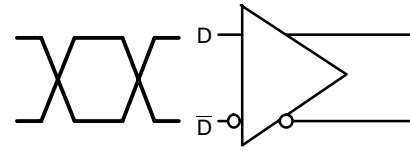


Figure 20. Differential Inputs Driven Differentially

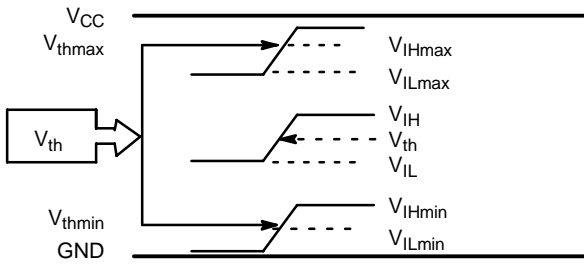


Figure 21. V_{th} Diagram

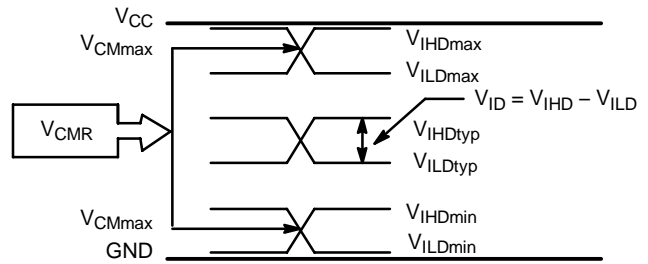


Figure 22. V_{CMR} Diagram

NB7N017M

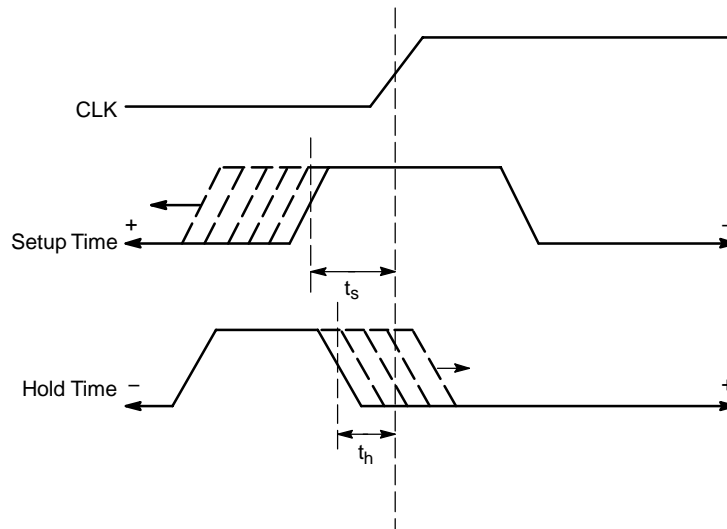


Figure 23. Setup and Hold Time

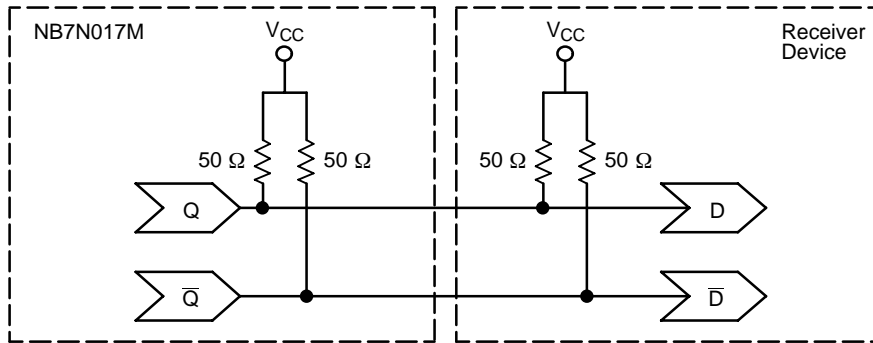


Figure 24. Typical Termination for 16 mA Output Drive and Device Evaluation

ORDERING INFORMATION

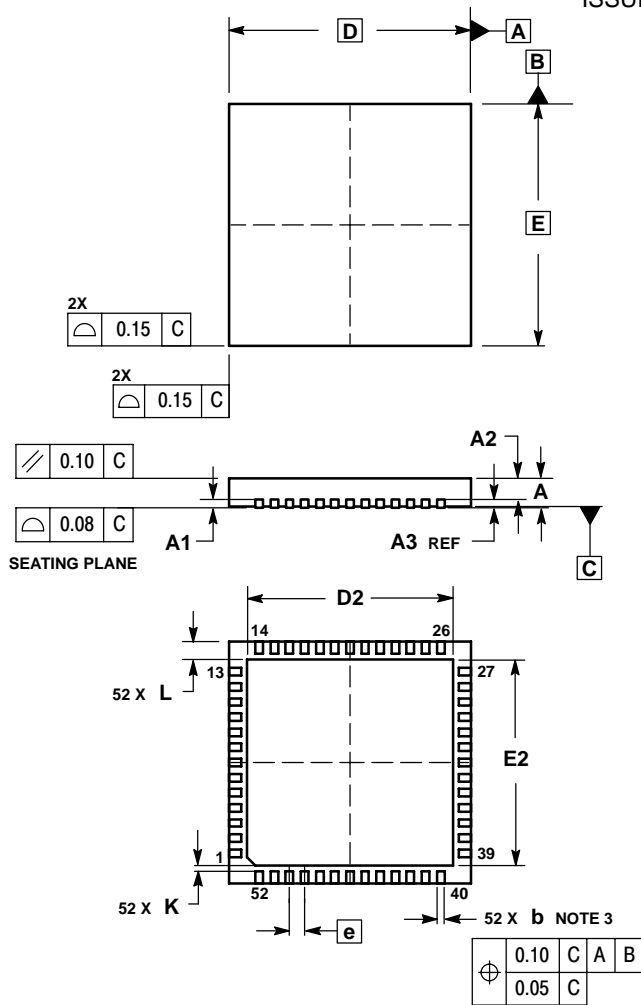
Device	Package	Shipping†
NB7N017MMN	QFN-52	260 Units / Tray
NB7N017MMNG	QFN-52 (Pb-Free)	260 Units / Tray
NB7N017MMNR2	QFN-52	2000 / Tape & Reel
NB7N017MMNR2G	QFN-52 (Pb-Free)	2000 / Tape & Reel

†For information on tape and reel specifications, including part orientation and tape sizes, please refer to our Tape and Reel Packaging Specifications Brochure, BRD8011/D.

NB7N017M

PACKAGE DIMENSIONS

52 PIN QFN 8x8
CASE 485M-01
ISSUE A



NOTES:

1. DIMENSIONING AND TOLERANCING PER ASME Y14.5M, 1994.
2. CONTROLLING DIMENSION: MILLIMETERS
3. DIMENSION b APPLIES TO PLATED TERMINAL AND IS MEASURED BETWEEN 0.25 AND 0.30 MM FROM TERMINAL.
4. COPLANARITY APPLIES TO THE EXPOSED PAD AS WELL AS THE TERMINALS.

DIM	MILLIMETERS	
	MIN	MAX
A	0.80	1.00
A1	0.00	0.05
A2	0.60	0.80
A3	0.20 REF	
b	0.18	0.30
D	8.00 BSC	
D2	6.50	6.80
E	8.00 BSC	
E2	6.50	6.80
e	0.50 BSC	
K	0.20	---
L	0.30	0.50

ON Semiconductor and are registered trademarks of Semiconductor Components Industries, LLC (SCILLC). SCILLC reserves the right to make changes without further notice to any products herein. SCILLC makes no warranty, representation or guarantee regarding the suitability of its products for any particular purpose, nor does SCILLC assume any liability arising out of the application or use of any product or circuit, and specifically disclaims any and all liability, including without limitation special, consequential or incidental damages. "Typical" parameters which may be provided in SCILLC data sheets and/or specifications can and do vary in different applications and actual performance may vary over time. All operating parameters, including "Typicals" must be validated for each customer application by customer's technical experts. SCILLC does not convey any license under its patent rights nor the rights of others. SCILLC products are not designed, intended, or authorized for use as components in systems intended for surgical implant into the body, or other applications intended to support or sustain life, or for any other application in which the failure of the SCILLC product could create a situation where personal injury or death may occur. Should Buyer purchase or use SCILLC products for any such unintended or unauthorized application, Buyer shall indemnify and hold SCILLC and its officers, employees, subsidiaries, affiliates, and distributors harmless against all claims, costs, damages, and expenses, and reasonable attorney fees arising out of, directly or indirectly, any claim of personal injury or death associated with such unintended or unauthorized use, even if such claim alleges that SCILLC was negligent regarding the design or manufacture of the part. SCILLC is an Equal Opportunity/Affirmative Action Employer. This literature is subject to all applicable copyright laws and is not for resale in any manner.

PUBLICATION ORDERING INFORMATION

LITERATURE FULFILLMENT:
Literature Distribution Center for ON Semiconductor
P.O. Box 61312, Phoenix, Arizona 85082-1312 USA
Phone: 480-829-7710 or 800-344-3860 Toll Free USA/Canada
Fax: 480-829-7709 or 800-344-3867 Toll Free USA/Canada
Email: orderlit@onsemi.com

N. American Technical Support: 800-282-9855 Toll Free
USA/Canada

Japan: ON Semiconductor, Japan Customer Focus Center
2-9-1 Kamimeguro, Meguro-ku, Tokyo, Japan 153-0051
Phone: 81-3-5773-3850

ON Semiconductor Website: <http://onsemi.com>

Order Literature: <http://www.onsemi.com/litorder>

For additional information, please contact your local Sales Representative.