

PART NUMBER	ITEM ①		ITEM ②	ITEM ③
	HANDLE	COLOR	CONTACT SPRING	BODY
108-0752-001	NYLON	BLACK	NICKEL SILVER	BRASS
108-0752-002		RED	NICKEL PL .0001 MIN	NICKEL PL .0001 MIN

DRAWING NO.		B-108-0752-001/002	
0	REVISIONS		
ENGINEERING RELEASE			
20	10-8-94	RH	SWTAKRJB ECN 42740

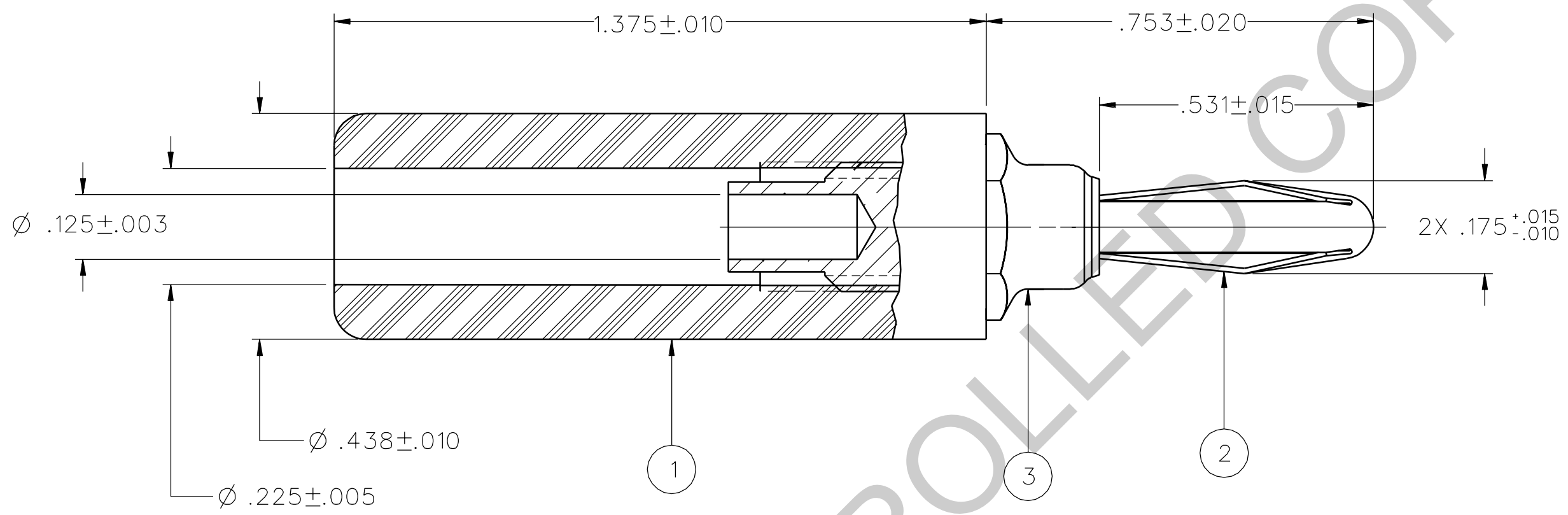

NOTES:

1. SPECIFICATIONS:

ELECTRICAL:

CURRENT RATING: 15 AMPS DC MINIMUM
 DIELECTRIC WITHSTANDING VOLTAGE: 3500 VRMS MIN AT SEA LEVEL
 RECOMMENDED WORKING VOLTAGE: 1750 VRMS MAX AT SEA LEVEL
 INSULATION RESISTANCE: 5000 MEGOHMS MIN
 CONTACT RESISTANCE: 10 MILLIOHMS MAXIMUM

MECHANICAL:

INSERTION/WITHDRAWAL FORCE: 1.0 - 12.0 POUNDS
 CONTACT SPRING RETENTION FORCE: 25 POUNDS MINIMUM
 WIRE ACCEPTABILITY: 10 AWG OR SMALLER
 WIRE ATTACHMENT: SOLDER
 MATING BANANA JACK DIAMETER: .166 NOMINAL
 DURABILITY: 1000 CYCLES MINIMUM

ENVIRONMENTAL:

(MEETS OR EXCEEDS THE APPLICABLE PARAGRAPH OF MIL-C-28901)
 OPERATING TEMPERATURE: -55 DEG C TO 85 DEG C.
 TEMPERATURE RISE AT RATED CURRENT: 10 DEG C MAXIMUM
 CORROSION: MIL-STD-1344, METHOD 1001, CONDITION B
 SHOCK: MIL-STD-1344, METHOD 2004, CONDITION G
 VIBRATION: MIL-STD-1344, METHOD 2005, CONDITION I
 HUMIDITY: MIL-STD-1344, METHOD 1002, CONDITION B

CUSTOMER DRAWING

THIS DRAWING TO BE INTERPRETED
 PER ASME Y 14.5M - 1994

"μSTATION"

COMPANY CONFIDENTIAL

TOLERANCE UNLESS OTHERWISE SPECIFIED		DRAWN BY	DATE
DECIMALS	mm	SWC	3-25-94
.XX	_____	CHECKED BY	DATE
.XXX	_____	TAK	10-11-94
MATL	_____	APPROVED BY	DATE
FINISH	_____	RJB	10-12-94
U/M	INCH	RELEASE DATE	10-12-94
		SCALE	4:1

 <p>Cinch CONNECTIVITY SOLUTIONS a bel group</p>	<p>Cinch Connectivity Solutions P.O. Box 1732 Waseca, MN 56093 1-800-247-8256</p>	
	<p>TITLE ASSEMBLY, BANANA PLUG, INSULATED HANDLE, HEX BODY SOLDER BACK HOLE</p>	
<p>SHEET 2 OF 2</p>	<p>DRAWING NO. B-108-0752-001/002</p>	