

1206 Package Infrared Chip LED With Inner Lens

EAIST3015A1



Features

- Small double-end package
- High reliability
- Low forward voltage
- Good spectral matching to Si photodetector
- Package in 8mm tape on 7" diameter reel
- Pb free
- The product itself will remain within RoHS compliant version.

Descriptions

EAIST3015A1 is an infrared emitting diode in miniature SMD package which is molded in a water clear plastic with flat top view lens.

The device is spectrally matched with silicon photodiode and phototransistor.

Applications

- PCB mounted infrared sensor
- Infrared emitting for miniature light barrier
- Floppy disk drive
- Optoelectronic switch
- Smoke detector

Device Selection Guide

Part No.	Chip Material	Resin Color
EAIST3015A1	GaAlAs	Water Clear

Package Dimensions

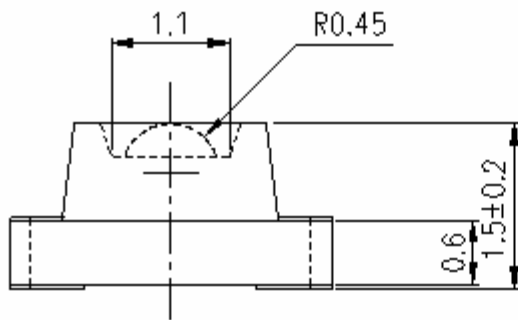
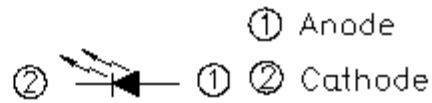
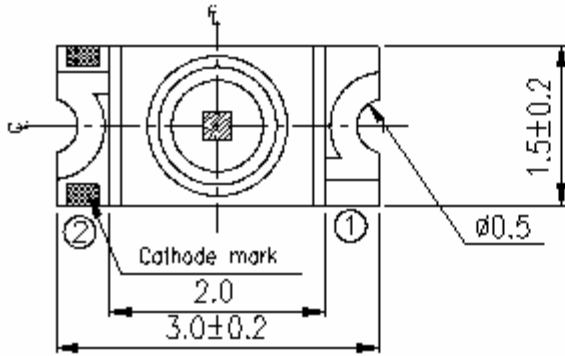

For reflow soldering (propose)

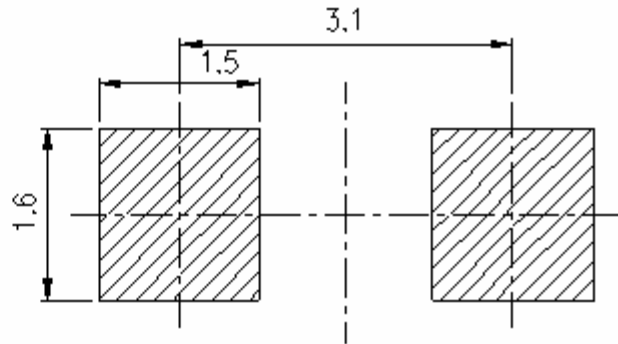
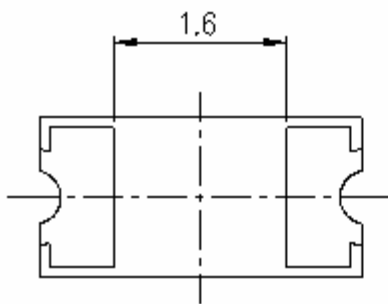

- Notes:**
1. All dimensions are in millimeters
 2. Tolerances unless dimensions ± 0.1 mm

Absolute Maximum Ratings (Ta=25°C)

Parameter	Symbol	Rating	Units
Reverse Voltage	V_R	5	V
Continuous Forward Current	I_F	65	mA
Power Dissipation at(or below) 25°C Free Air Temperature	P_d	130	mW
Operating Temperature	T_{opr}	-25 ~ +85	°C
Storage Temperature	T_{stg}	-40 ~ +100	°C
Soldering Temperature	T_{sol}	Reflow Soldering : 260 °C for 10 sec. Hand Soldering : 350 °C for 3 sec.	

Electro-Optical Characteristics (Ta=25°C)

Parameter	Symbol	Min.	Typ.	Max.	Unit	Condition
Radiant Intensity	I_e	1.25	2.25	----	mW/sr	$I_F=20mA$
Viewing Angle	$2\theta_{1/2}$	----	100	----	deg	
Peak Wavelength	λ_p	----	940	----	nm	
Spectrum Radiation Bandwidth	$\Delta\lambda$	----	45	----	nm	
Forward Voltage	V_F	----	1.2	1.5	V	
Reverse Current	I_R	----	----	10	μA	$V_R=5V$

Typical Electro-Optical Characteristics Curves

Fig.1 Forward Current vs. Ambient Temperature

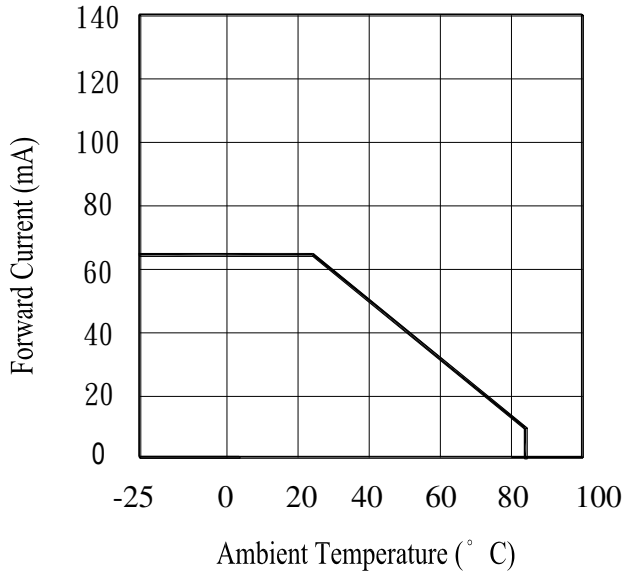

Fig.2 Spectral Distribution

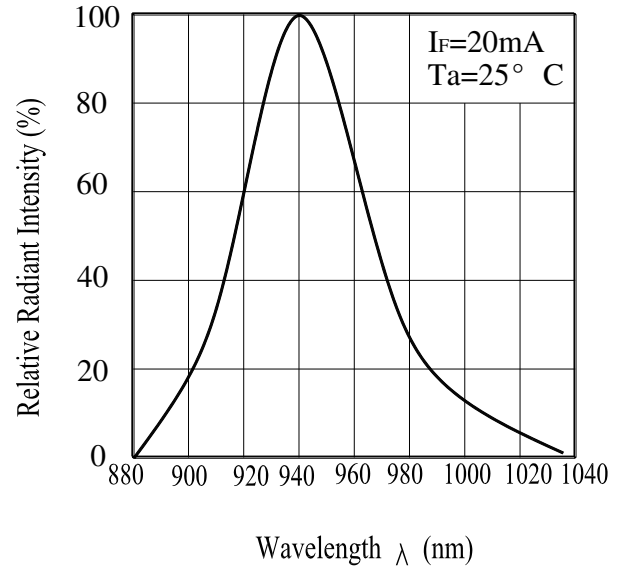

Fig.3 Peak Emission Wavelength vs. Ambient Temperature

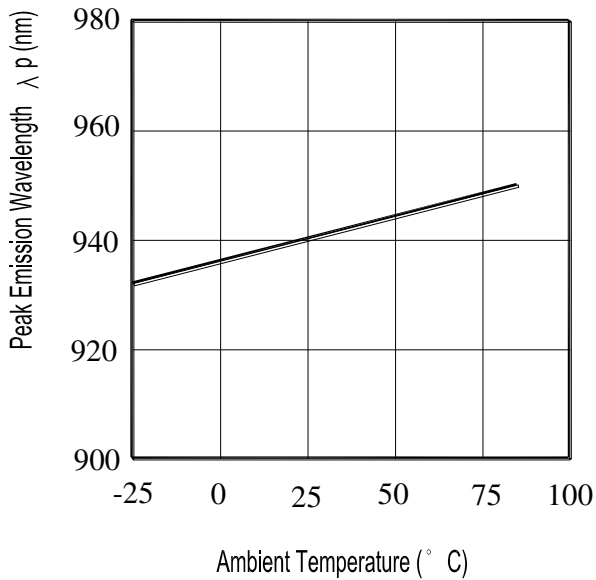
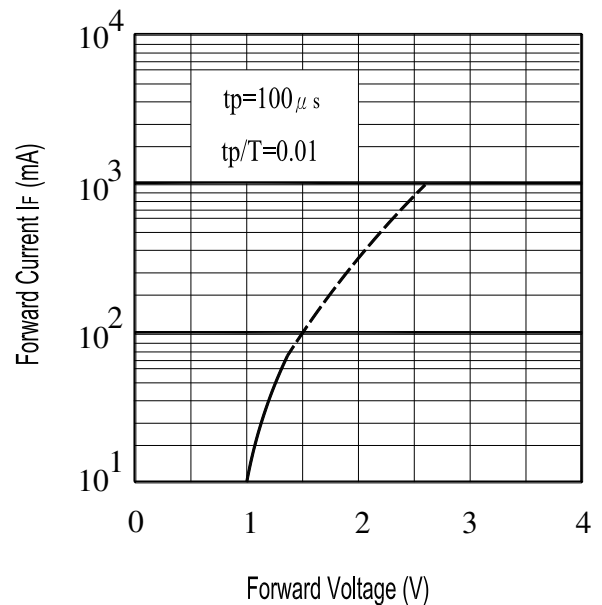

Fig.4 Forward Current vs. Forward Voltage



Typical Electro-Optical Characteristics Curves

Fig.5 Relative Intensity vs.
 Forward Current

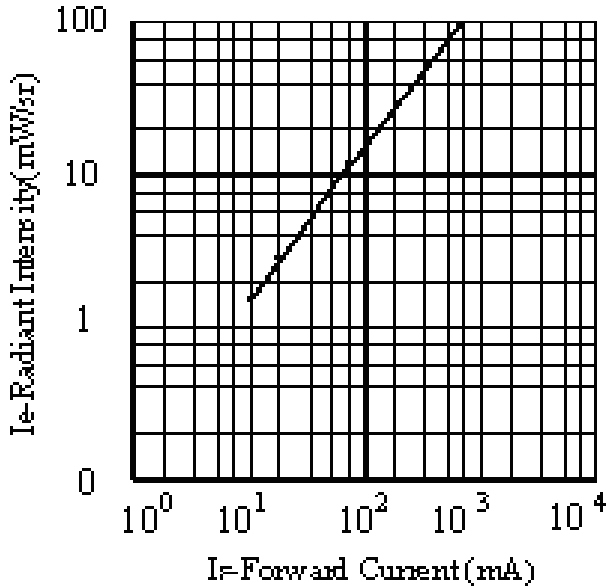
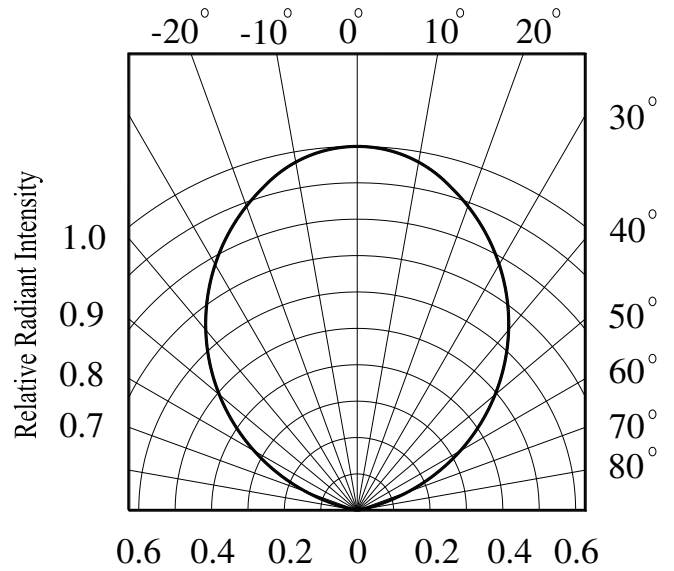

Fig.6 Relative Radiant Intensity vs.
 Angular Displacement



Precautions For Use

1. Over-current-proof

Customer must apply resistors for protection, otherwise slight voltage shift will cause big current change (Burn out will happen).

2. Storage

2.1 Do not open moisture proof bag before the products are ready to use.

2.2 Before opening the package: The LEDs should be kept at 30°C or less and 90%RH or less.

2.3 The LEDs should be used within a year.

2.4 After opening the package, the LEDs should be kept at 30°C or less and 60%RH or less.

2.5 The LEDs should be used within 168 hours (7 days) after opening the package.

2.6 If the moisture absorbent material (silica gel) has faded away or the LEDs have exceeded the storage time, baking treatment should be performed using the following conditions.

Baking treatment : 60±5°C for 48 hours.

3. Soldering Condition

3.1 Pb-free solder temperature profile

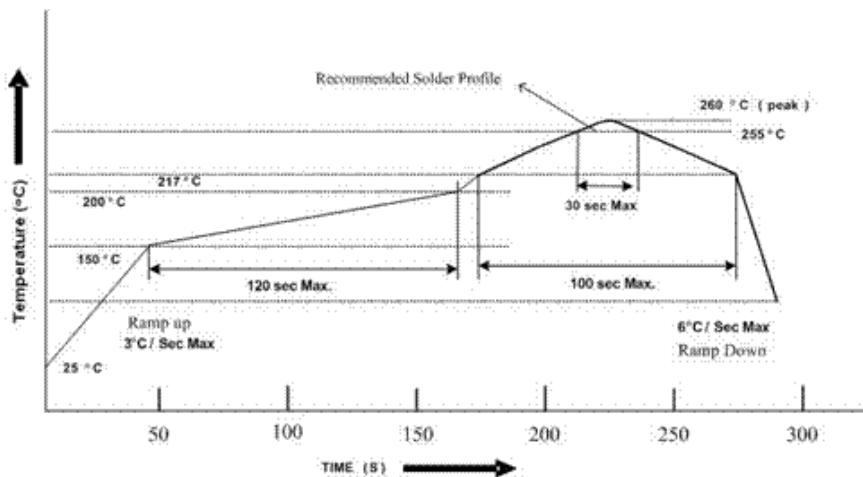

3.2 Reflow soldering should not be done more than two times.

3.3 When soldering, do not put stress on the LEDs during heating.

3.4 After soldering, do not warp the circuit board.

4. Soldering Iron

Each terminal is to go to the tip of soldering iron temperature less than 350°C for 3 seconds within once in less than the soldering iron capacity 25W. Leave two seconds and more intervals, and do soldering of each terminal. Be careful because the damage of the product is often started at the time of the hand solder.

5. Repairing

Repair should not be done after the LEDs have been soldered. When repairing is unavoidable, a double-head soldering iron should be used (as below figure). It should be confirmed beforehand whether the characteristics of the LEDs will or will not be damaged by repairing.

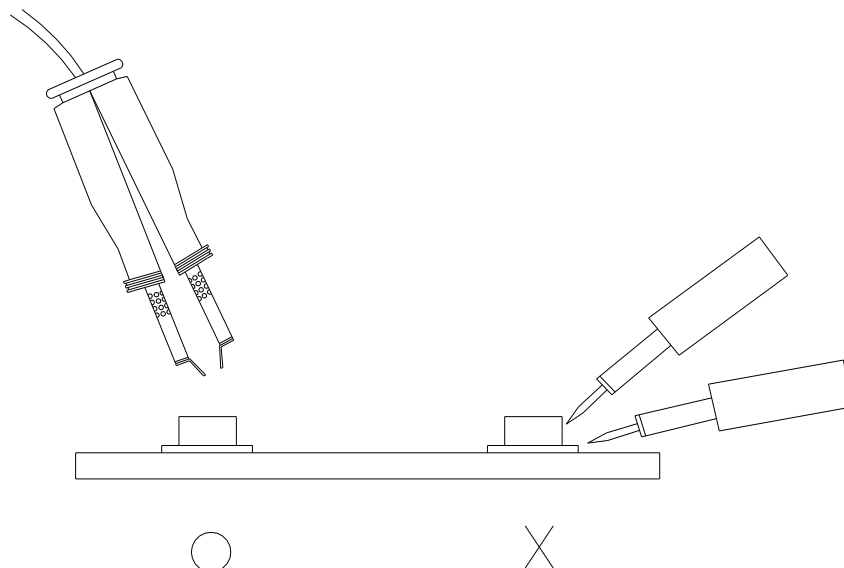

Package Dimensions

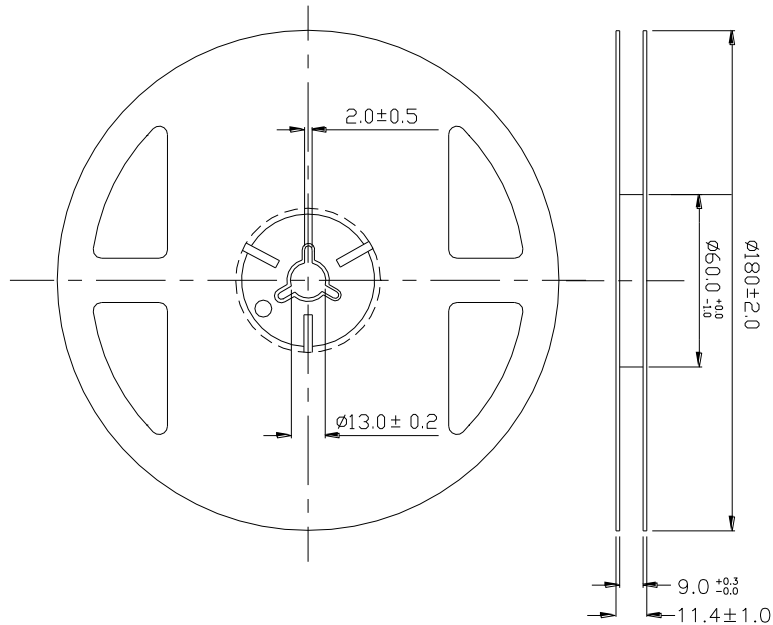

Note: The tolerances unless mentioned are ± 0.1 , unit=mm.

Carrier Taping Dimensions: Loaded Quantity Per Reel 2000PCS/Reel

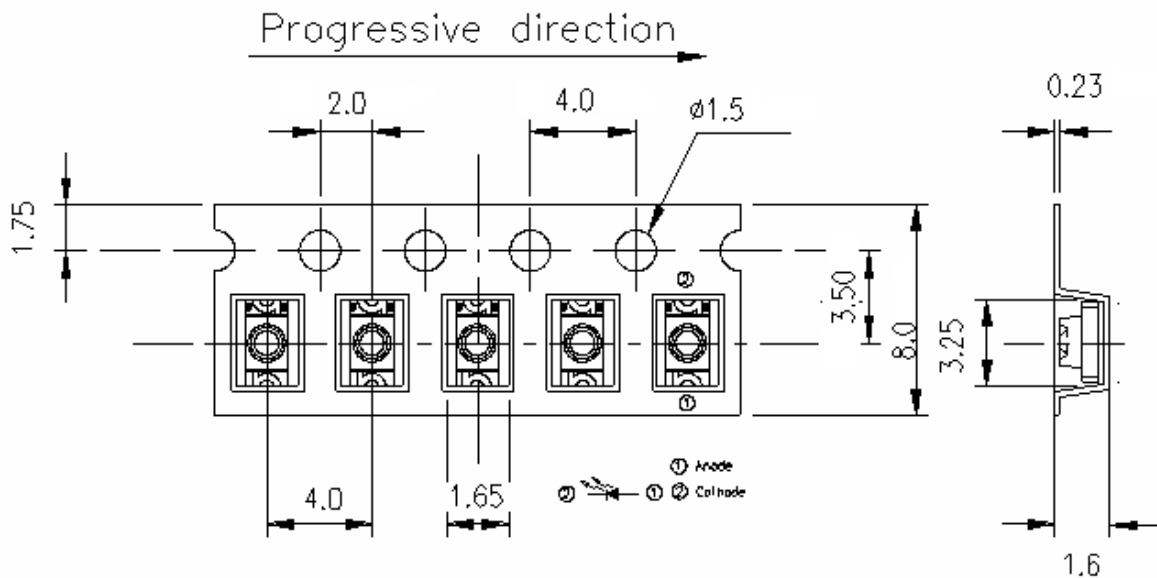

Note: The tolerances unless mentioned is ± 0.1 mm, Unit = mm

Label Form Specification

Pb EVERLIGHT AMERICA

CPN: XXXXXXXXXXXX
P/N: XXXXXXXXXXXX
XXXXXXXXXXXXXXXXXXXX
QTY: XXXX CAT: XXX
HUE: XXX
REF: XXX
LOT NO: XXXXXXXXXXXXXXXXXXXX
REFERENCE: XXXXXXXXXXXX
XXXXXXXXXXXXXXXXXXXX

RoHS

MADE IN TAIWAN

CPN: Customer's Production Number

P/N : Production Number

QTY: Packing Quantity

CAT: Ranks

HUE: Peak Wavelength

REF: Reference

LOT No: Lot Number

Notes

1. Above specification may be changed without notice. Everlight Americas will reserve authority on material change for above specification.
2. When using this product, please observe the absolute maximum ratings and the instructions for using outlined in these specification sheets. Everlight Americas assumes no responsibility for any damage resulting from use of the product which does not comply with the absolute maximum ratings and the instructions included in these specification sheets.
3. These specification sheets include materials protected under copyright of Everlight Americas corporation. Please don't reproduce or cause anyone to reproduce them without Everlight Americas's consent.