



## FEATURES

Interleaved Boost PFC topology providing high power factor and low THD  
Protection features for AC line input and high voltage output  
Current balancing between two phases  
High efficiency  
I2C serial interface to PC  
Software GUI  
Programmable digital filters  
Programmable response to faults  
Programmable inrush control  
Accurate AC power metering  
Digital Calibration and trimming

## CAUTION

This evaluation board uses high voltages whenever it is powered up. The output capacitor has high level of energy stored and it must be discharged before the load is disconnected. Extreme caution must be taken to ensure safety for the user. It is strongly advised to power down the evaluation board when not in use.

## ADP1048 EVALUATION BOARD OVERVIEW

This evaluation board features the ADP1048 in a switching power supply application. With the evaluation board and software, the ADP1048 can be interfaced to any PC running Windows 2000/XP/Vista/NT via the computer's USB port. The software allows control and monitoring of the ADP1048 internal registers. The board is set up for the ADP1048 to act as boost power factor correction circuit with a rated load of 600W from an input voltage ranging from a 85 V<sub>RMS</sub> to 265 V<sub>RMS</sub>.

## EVALUATION SYSTEM CONTENTS

The evaluation system package contains the following items:

- Application note EVAL-ADP1048 (order code: ADP1048-600-EVALZ)
- ADP1048 evaluation board

The USB/I2C adapter for serial communication and software CD need to be ordered separately.

### Rev. 1.3

Reference designs are as supplied "as is" and without warranties of any kind, express, implied, or statutory including, but not limited to, any implied warranty of merchantability or fitness for a particular purpose. No license is granted by implication or otherwise under any patents or other intellectual property by application or use of reference designs. Information furnished by Analog Devices is believed to be accurate and reliable. However, no responsibility is assumed by Analog Devices for its use, nor for any infringements of patents or other rights of third parties that may result from its use. Analog Devices reserves the right to change devices or specifications at any time without notice. Trademarks and registered trademarks are the property of their respective owners. Reference designs are not authorized to be used in life support devices or systems.

## TABLE OF CONTENTS

Features .....	1
CAUTION .....	1
TOPOLOGY AND circuit description .....	3
CONNECTORS .....	3
SETTING FILES AND EEPROM .....	5
BOARD EVALUATION .....	6
EQUIPMENT .....	6
SETUP .....	8
ADP1048 PROGRAMMING SOFTWARE .....	10
APPENDIX I – SCHEMATIC (MAIN BOARD) .....	11
APPENDIX II – SCHEMATIC (DAUGHTER CARD) .....	14
APPENDIX III – LAYOUT (MAIN BOARD) .....	15
APPENDIX IV – LAYOUT (DAUGHTER CARD) .....	17
APPENDIX X – BILL OF MATERIALS (MAIN BOARD) .....	20
APPENDIX XI – BILL OF MATERIALS (DAUGHTER CARD) .....	23
APPENDIX XII – REGISTER FILE (RevA_IC revised-0408.48r) .....	24
Notes .....	26

## DEMO BOARD SPECIFICATIONS

<i>Specification</i>	<i>MIN</i>	<i>TYP</i>	<i>MAX</i>	<i>Units</i>	<i>Notes</i>
$V_{IN}$	85	115 or 230	265	$V_{RMS}$	
$V_{OUT}$		385		V	
$P_{OUT}$	0.0		600	W	
$T_{AMBIENT}$	0	30	65	°C	
Efficiency		95		%	
Switching frequency		97.7		KHz	

Table 1 - Target Specifications

## TOPOLOGY AND CIRCUIT DESCRIPTION

This evaluation board features the ADP1048 in a typical AC/DC switching power supply in an interleaved boost power factor correction (PFC) topology. The circuit is designed to provide a rated load of 385V/600W from an AC input voltage source of 85 V<sub>RMS</sub> to 265 V<sub>RMS</sub> AC. The ADP1048 provides functions all the functions necessary for active PFC circuit plus accurate AC power metering. It achieves near-unity power factor, low distortion of the input current, the output voltage regulation, over current protection, AC line fault detection and protection, over temperature protection, and power supply shutdown. It also can optimize light load efficiency performance using output voltage adjustment and frequency reduction.

Please refer to the appendix for the detailed schematic. The AC input side consists of the input terminals, EMI filter, inrush relay and its control circuit. The D1 is the rectifier bridge for main power transmission. The D4 is used for input voltage sensing. The boost circuit consists boost inductor (L2), boost switch (Q1) and diode (D2). The gate signal for the boost switch comes from the ADP1048 through the ADP3634 gate driver. The ADP1048 (U1, on daughter card) can be powered either via the USB 5V via an ADP3303 LDO (U2, on daughter card) present on the same daughter card, or via the auxiliary power supply on the board. Thermistor (RTD1) is placed close to the MOSFET on the board allowing over temperature protection functionality to be implemented.

## CONNECTORS

The connections to the evaluation board are shown below.

Connector	Evaluation Board Function
J1	AC Input
J9, J10	AC Input
J4	385V DC Voltage Output
J5	Ground Return for 385 V DC Voltage Output
J8, J11	I2C Connector
J6	Daughter card

Table 2 - Evaluation board connectors

There is a 4 pin connector for I2C communication. This allows the software to communicate with the evaluation board through the USB port of the PC. Connectors (J8 and J11) are identical and are connected in parallel to each other to allow multiple boards to be connected to the same I2C bus in a daisy chain configuration.

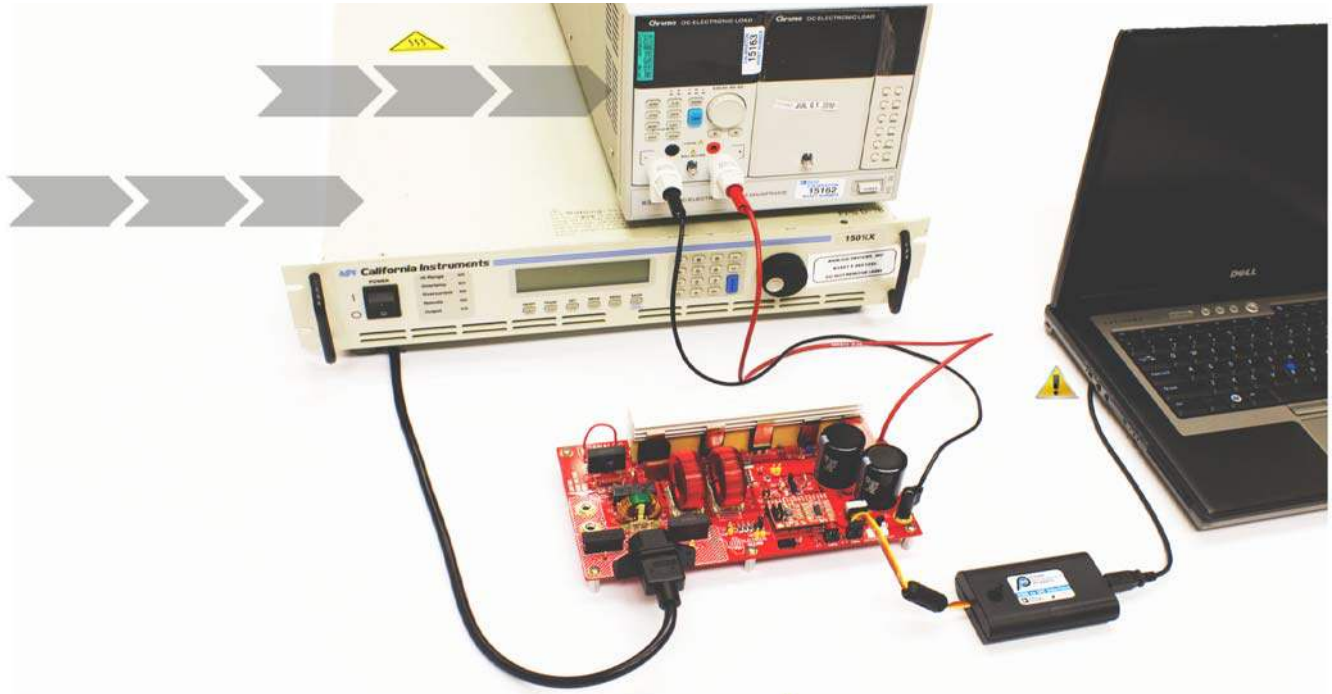

Figure 1 - Evaluation Board Setup

Pin	Evaluation Board Function
1	5V
2	SCL
3	SDA
4	Ground

Table 3 - J8, J11 connections

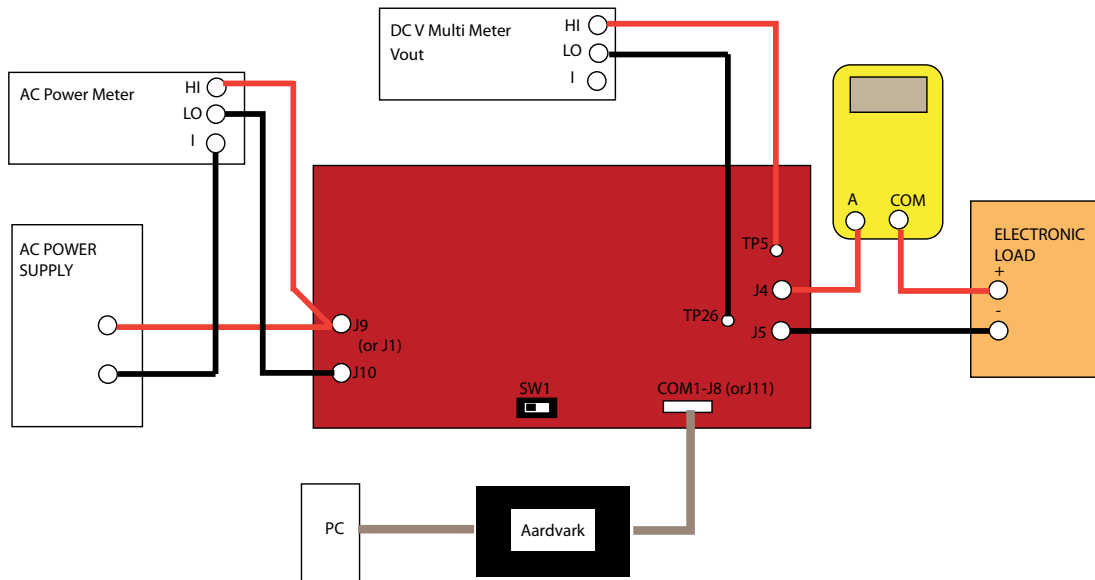

Figure 2 - Test configuration for the Evaluation Board

## SETTING FILES AND EEPROM

The ADP1048 communicates with the GUI software using the I2C bus.

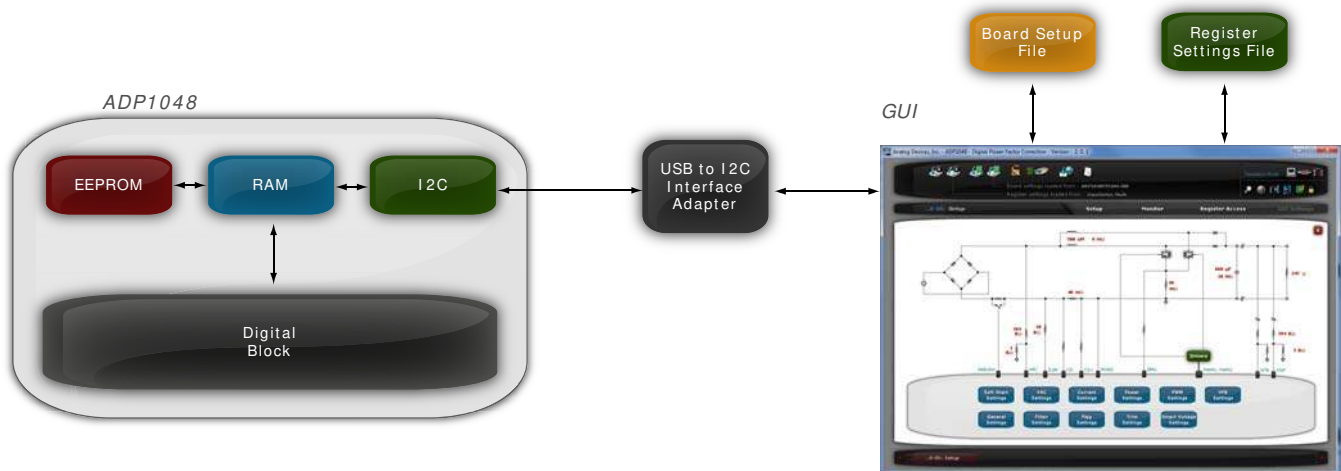

Figure 3 - ADP1048 and GUI interaction

The register settings (having extension .48r) and the board settings (having extension .48b) are two files that are associated with the ADP1048 software. The register settings file contains information that govern the functionality of the part such as the over voltage and over current limits, softstart timing, PWM settings etc. The ADP1048 stores all its settings in the EEPROM. When the ADP1048 is connected to the USB adapter the LDO powers the I.C. and the GUI downloads the settings from the registers of the ADP1048 so that the state of the part is known. It is possible to save these settings in a file for later use. Older register settings are overwritten when new files are loaded.

The EEPROM on the ADP1048 can contain the information about the board, such as current sense resistor, output inductor and capacitor values. This information is also stored in board setup file (extension .48b) and is necessary for the GUI to display the correct information in the 'Monitor' tab as well as 'Filter Settings' window. Always make sure that the correct board file has been loaded for the board currently in use.

Each ADP1048 chip has trim registers for the temperature, input current and the output voltage and input voltage. These can be configured during production and are not overwritten whenever a new register settings file is loaded. This is done in order to retain the trimming of all the ADCs for that corresponding environmental and circuit condition (component tolerances, thermal drift, etc.).

## BOARD EVALUATION

### EQUIPMENT

- AC Power Supply
- Electronic Load
- Oscilloscope with differential probes
- PC with ADP1048 GUI installed
- Precision Digital Multimeters (HP34401 or equivalent - 6 digits) for measuring DC current and voltage

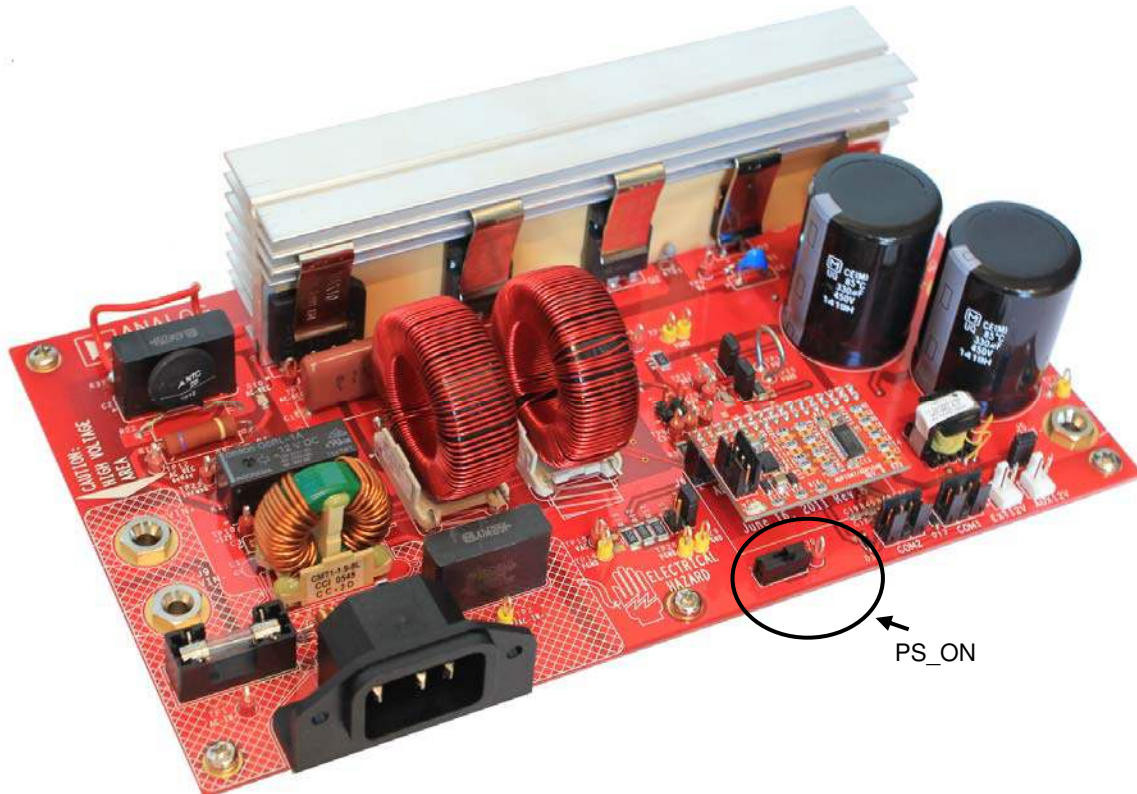

Figure 4 - 600W evaluation board showing PS\_ON hardware switch

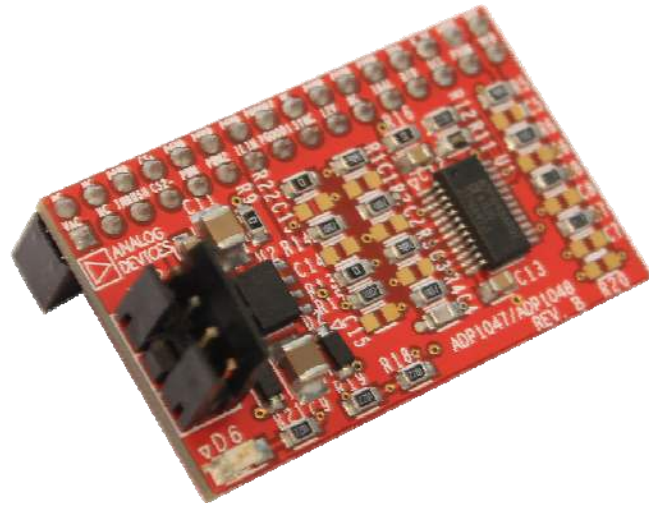

Figure 5 - ADP1048 daughter card

## SETUP

**NOTE: DO NOT CONNECT THE USB CABLE TO THE EVALUATION BOARD UNTIL THE SOFTWARE HAS FINISHED INSTALLING**

- 1) Install the ADP1048 software by inserting the installation CD. The software setup will start automatically and a guided process will install the software as well as the USB drivers for communication of the GUI with the IC using the USB adapter.
- 2) Insert the daughter card in connector J6 as shown in Figure 4.
- 3) Ensure that the PS\_ON switch (SW1 on schematic) is turned to the on position. It is located on the bottom left half of the board (Figure 4).
- 4) Connect the evaluation board to the USB port on the PC using the “USB to I2C interface” adapter as shown in Figure 1.
- 5) The software should report that the ADP1048 has been located on the board. Click “Finish” to proceed to the Main Software Interface Window. The serial number reported on the side of the checkbox indicates the USB adapter serial number. The windows also displays the device I2C address.



Figure 6 - ADP1048 address in the GUI

- 6) If the software does not detect the part it enters into simulation mode. Ensure that the connector is connected to J8/J11 (on main board) Click on ‘Scan for ADP1048A now’ icon (magnifying glass) located on the top right hand corner of the screen.



Figure 7 - “Scan for ADP1048 Now’ icon

- 7) **The board setting is store in the IC and this step is optional.** Click on the “Load Board Settings” icon (fourth button from the left) and select the ADI default.**48b** file. This file contains all the board information including values of shunt and voltage dividers. Note: All board setting files have an extension of .48b



Figure 8 - Different icons on dashboard for loading and saving .48r and .48b files

- 8) **The IC on the evaluation board comes preprogrammed and this step is optional.** The original register configuration is stored in the ADP1048.**48r** register file. Note: All register files have an extension of .48r. The file can be loaded using the second icon from the left in Figure .



- 9) Connect a resistive or electronic load to the output connections of Vout+ and Vout-. Note that the load should be connected before the input power is supplied to the evaluation board for safety concerns.
- 10) Connect a 50 or 60 Hz ac power source, which has to be turned off, to ac plug J1 or terminals J9 and J10.
- 11) Turn on AC power source and increase the input voltage within the range from 85Vrms to 265Vrms.
- 12) The evaluation board should now up and running, and ready for evaluation. The output should now read about 385 VDC.
- 13) Click on the 'MONITOR' tab and then on the Flags and readings icon. This window provides a snapshot of the entire state of the PSU in a single user friendly window.



Figure 9 - Monitor window in GUI

During power up, the ADP1048 is connected to the USB port (5V) and the LDO powers the IC. It takes 20µsec for Vcore (pin 26) to reach an internal voltage of 2.5V. After this, the I.C. downloads the contents of the registers into the EEPROM. After this the softstart ramp begins.

After successful startup and in steady state condition, 5 LEDs on the board to provide to the user the status of the board. All the LEDs will be turned ON indicating that there are no faults detected such as over voltage or over current. In case of a fault the PGOOD or AC\_OK LEDs will be turned OFF indicating that some flag has tripped due to an out of bounds condition. The monitor window will display the appropriate state of the PSU.

LED	Location	Description
D7	Bottom left	Inrush signal
D8	Bottom right	PGOOD signal (active high)
D9	Bottom right	AC_OK signal (active high)
D10	Bottom right	Indicates input voltage is present
D11	Top right	Indicates 12V or USB5V is present

Table 4 – List of LEDs on the evaluation board

## ADP1048 PROGRAMMING SOFTWARE

The goal of this evaluation kit is to allow the user to get an insight into the flexibility offered by the extensive programming options offered by the ADP1048. Several test points on the board allow easy monitoring of the various signals. The user can also use the software to program multiple responses (such as disable power supply or disable the PWM) for various fault conditions. There are several main windows where the user can use to program and evaluate the PSU. They can be accessed from the Setup window in the GUI. The ADP1048 can be easily programmed to modify the behavior of the PSU under different fault and load conditions without any hardware changes. All the changes are purely through software and do not require desoldering components and replacing them with new values to specify a different operating condition

APPENDIX I – SCHEMATIC (MAIN BOARD)

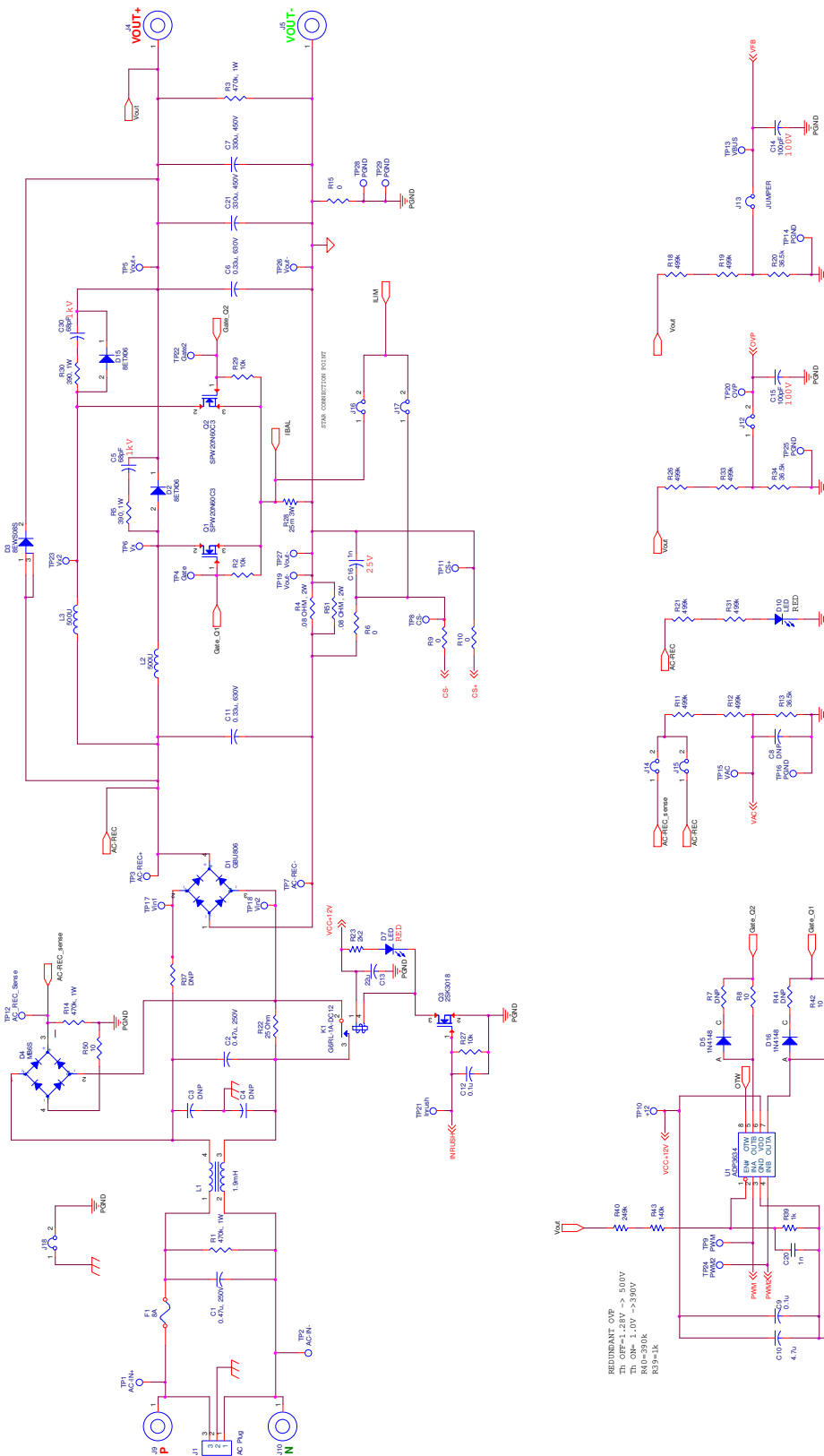

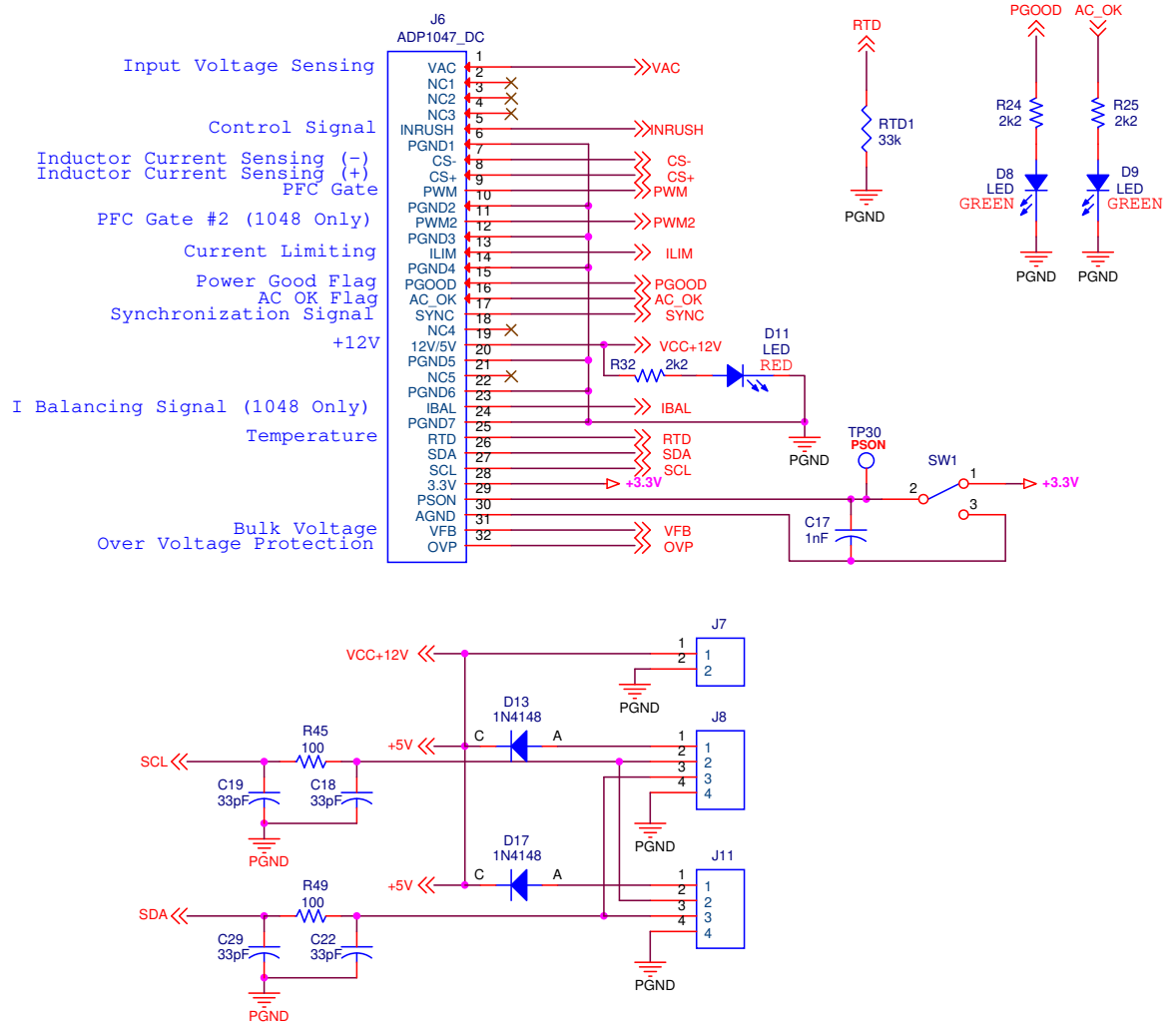

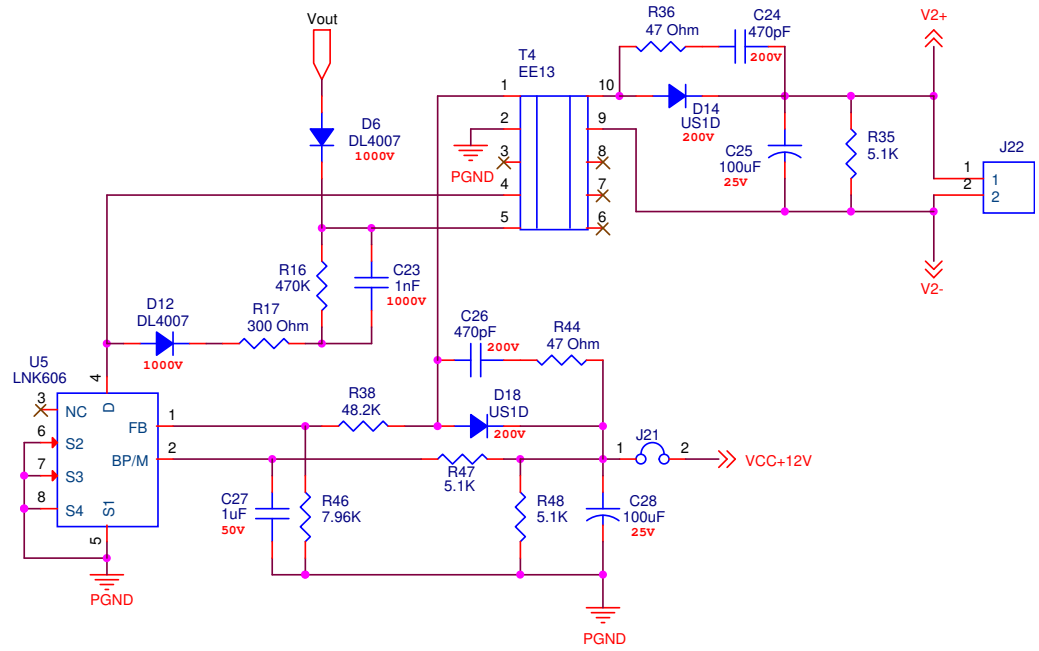

APPENDIX II – SCHEMATIC (DAUGHTER CARD)

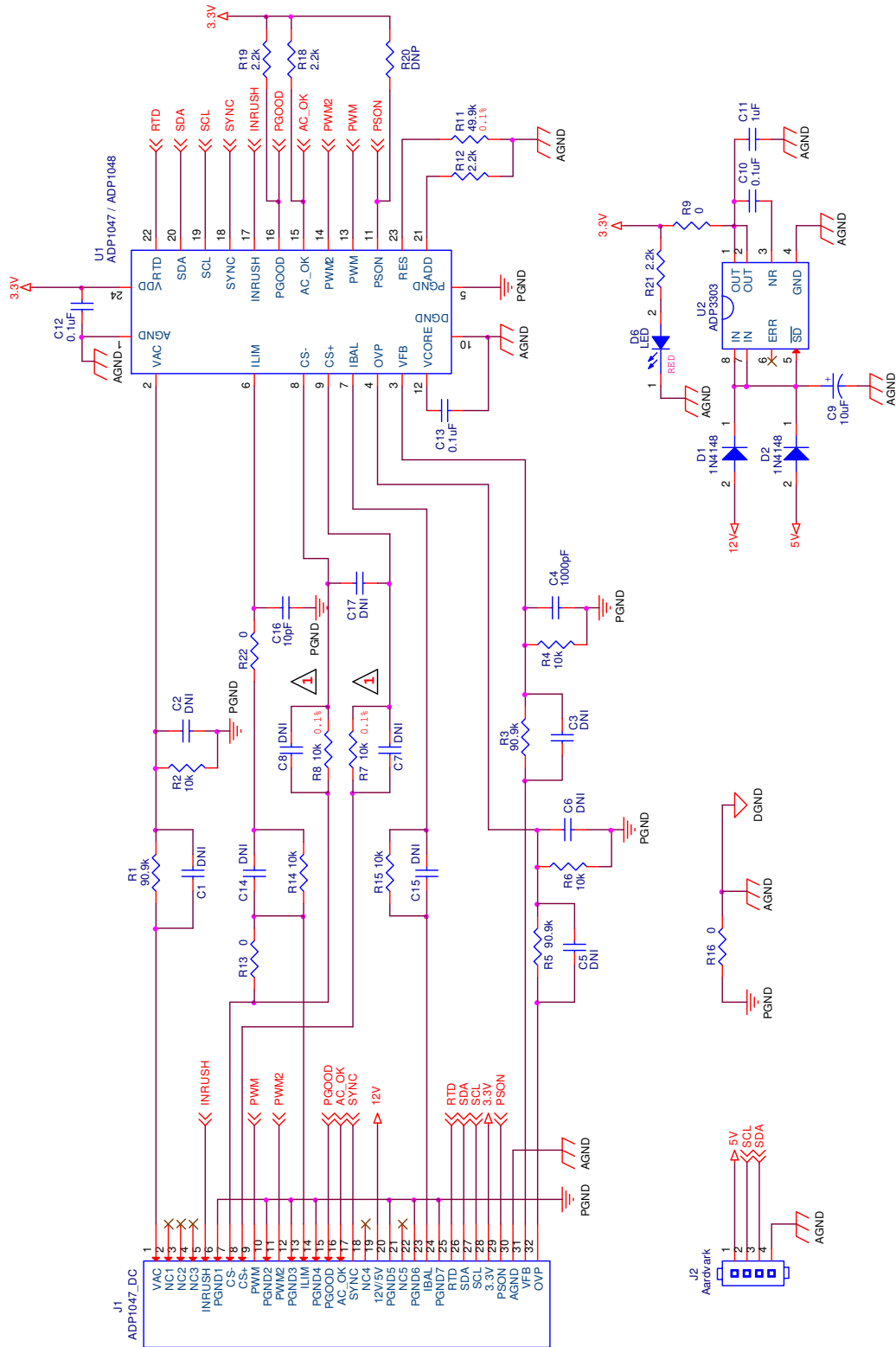

### APPENDIX III – LAYOUT (MAIN BOARD)

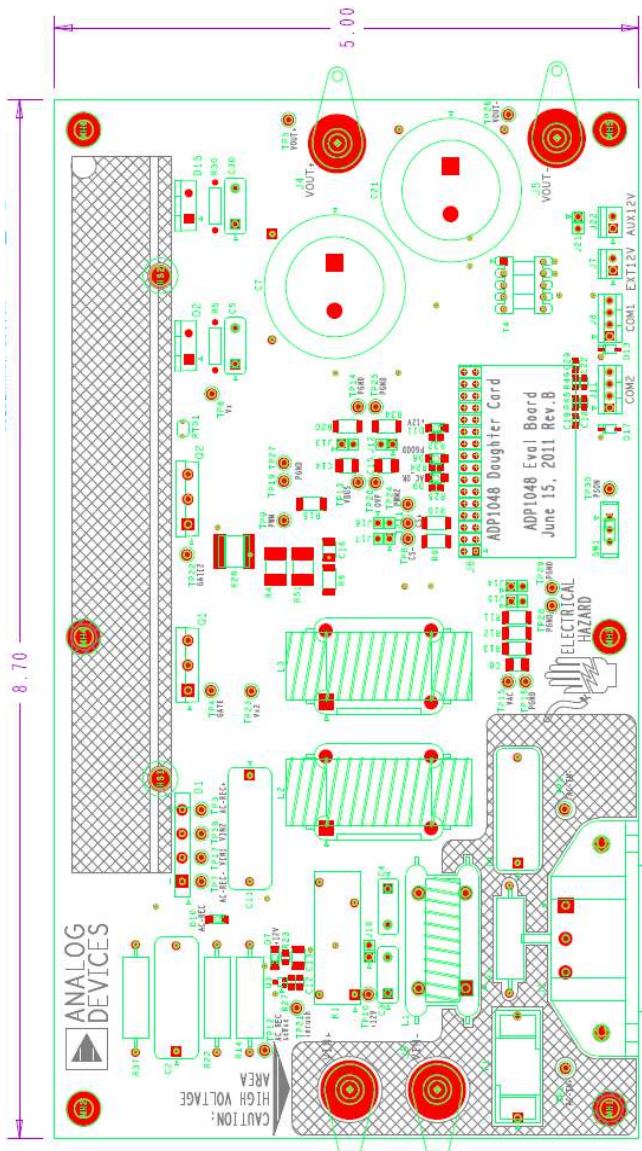

Figure 10 – Layout, Top Silkscreen

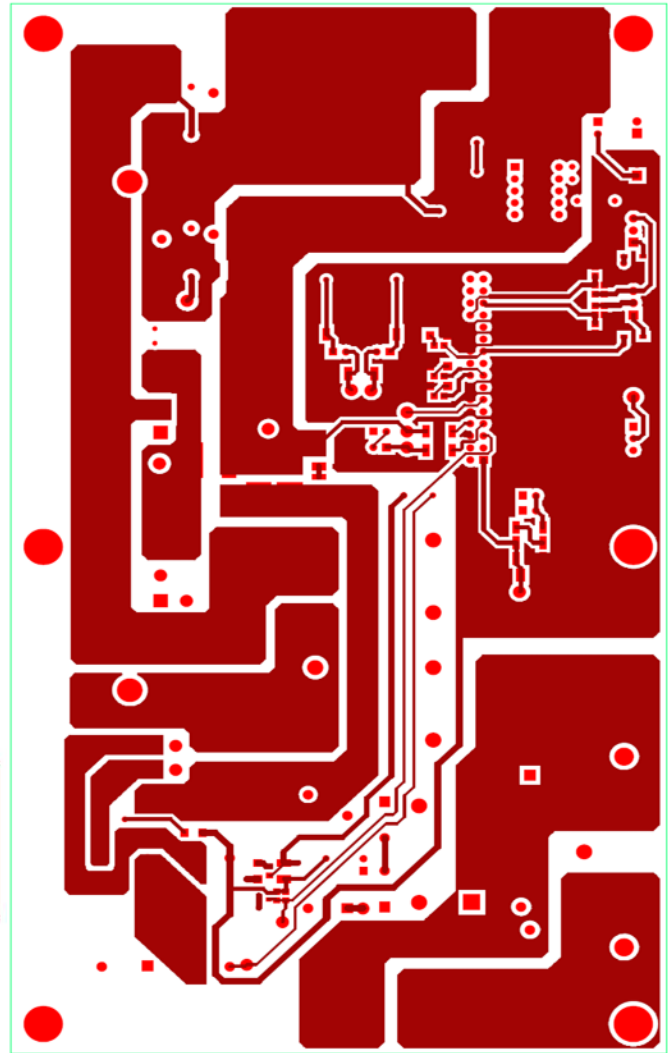

Figure 11 - Layout, Top layer

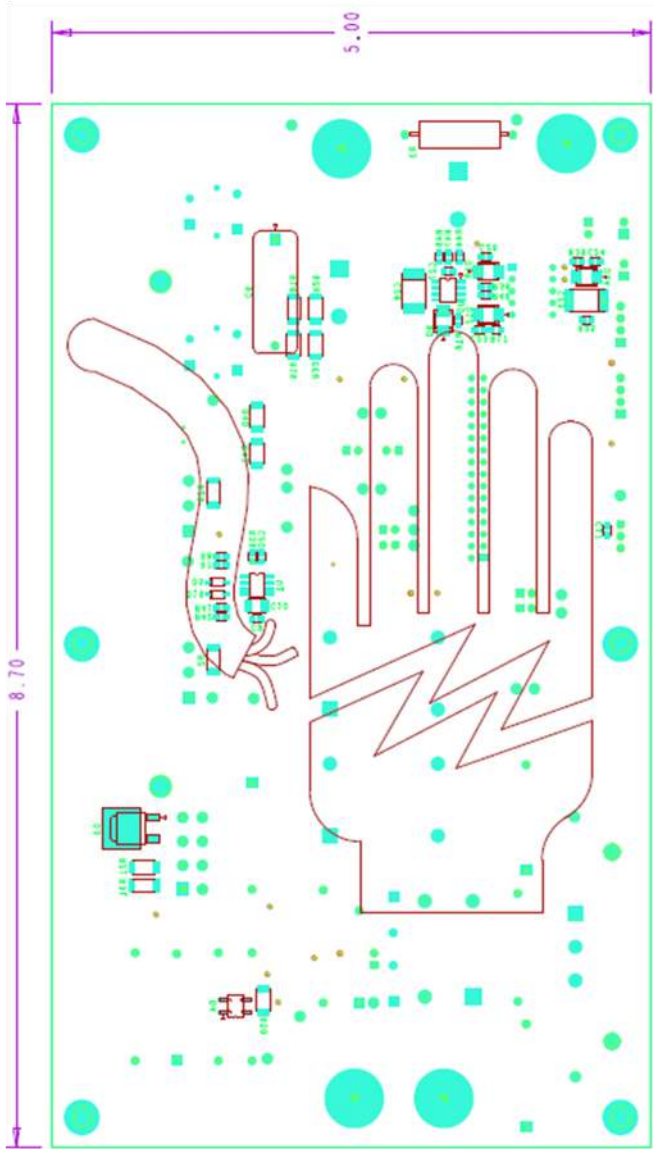

Figure 12 - Layout, Bottom silkscreen

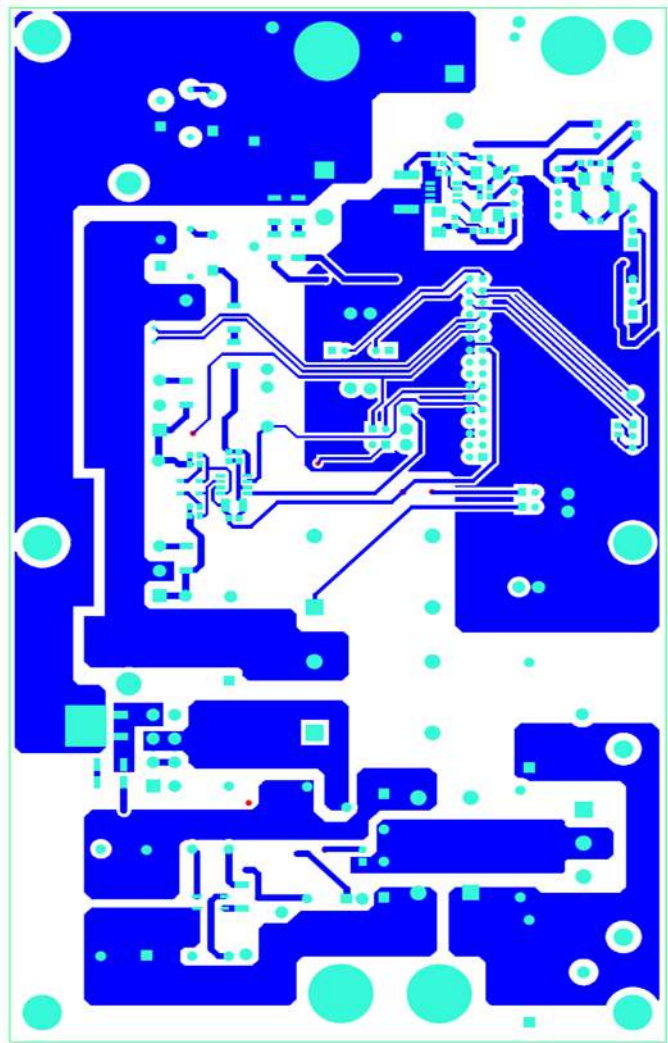

Figure 13 - Layout, Bottom layer



**APPENDIX IV – LAYOUT (DAUGHTER CARD)**

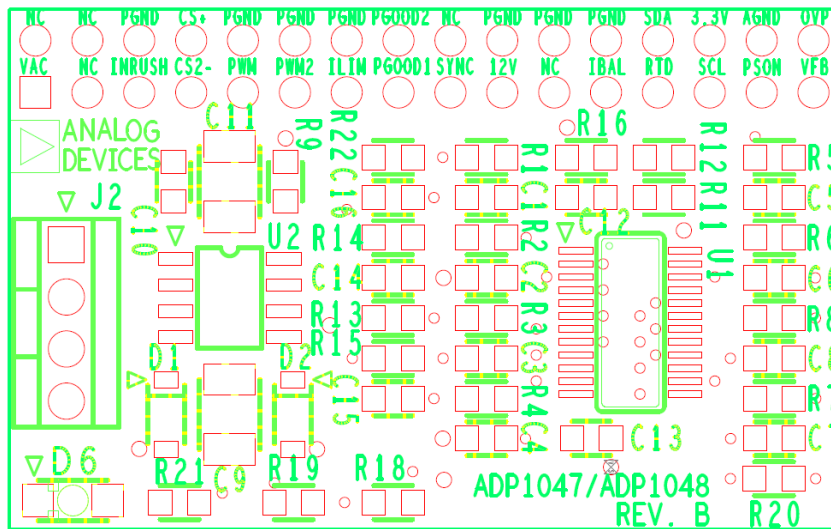

Figure 14 – Top silkscreen

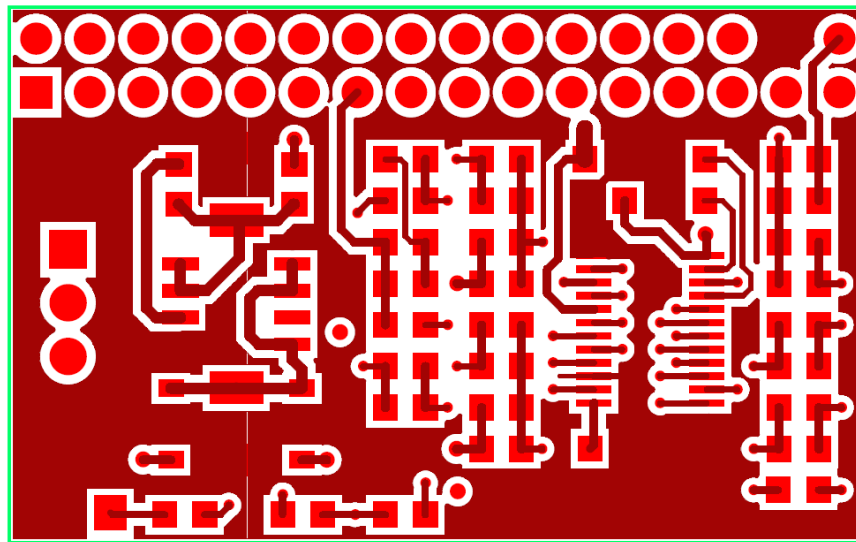

Figure 15 - Top Layer,

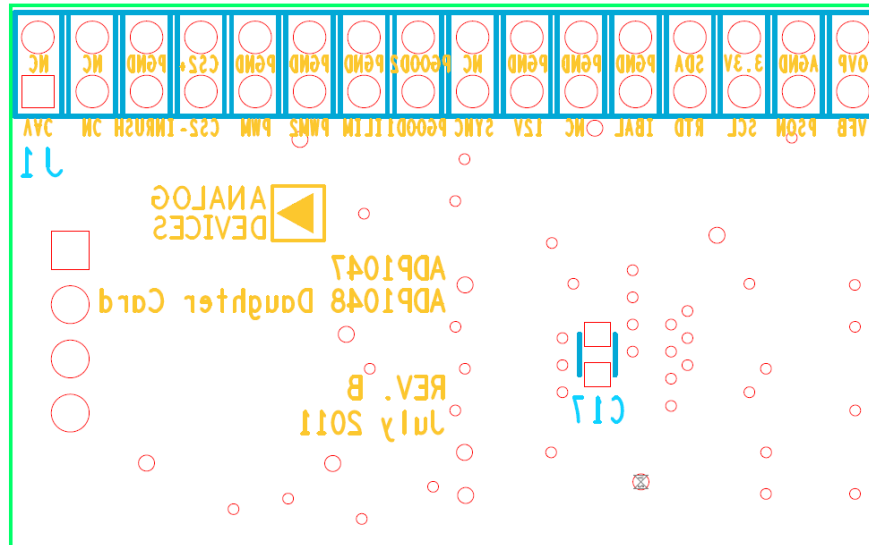

Figure 16 – Bottom Silkscreen

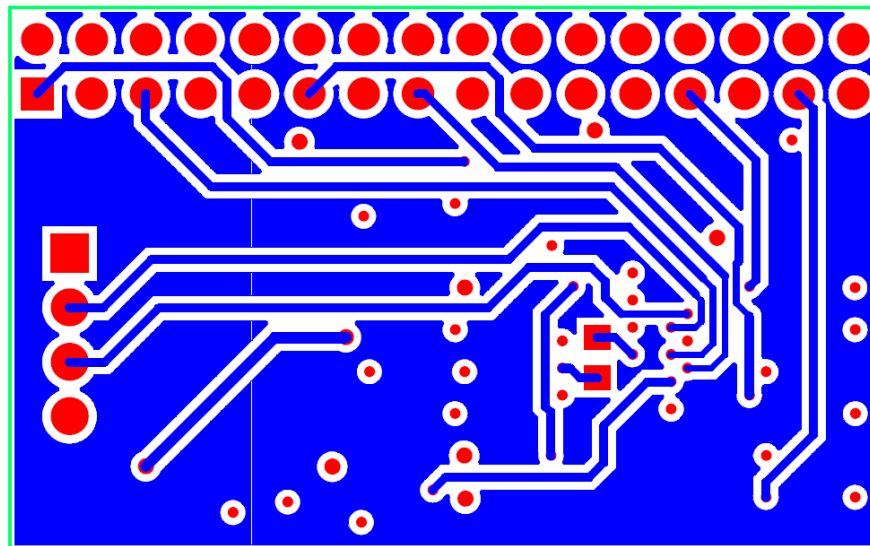

Figure 17 – Bottom layer

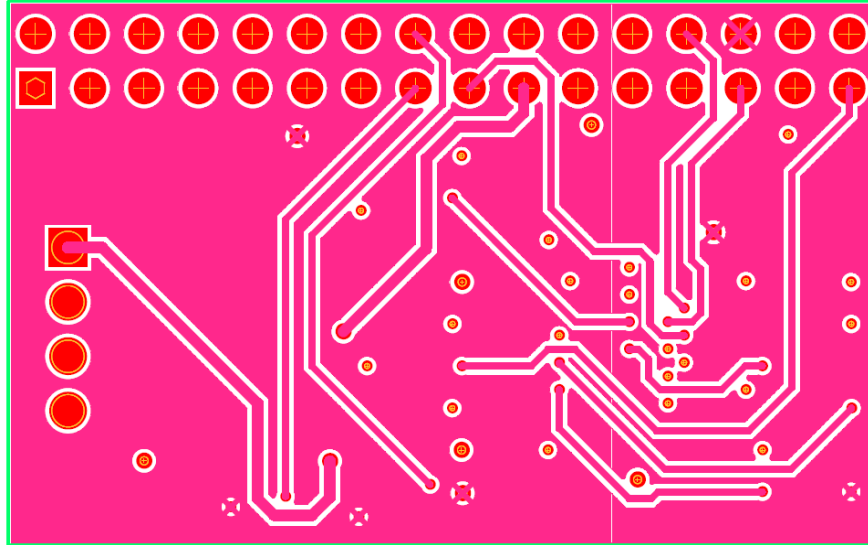

Figure 18 – Inner layer1 layout

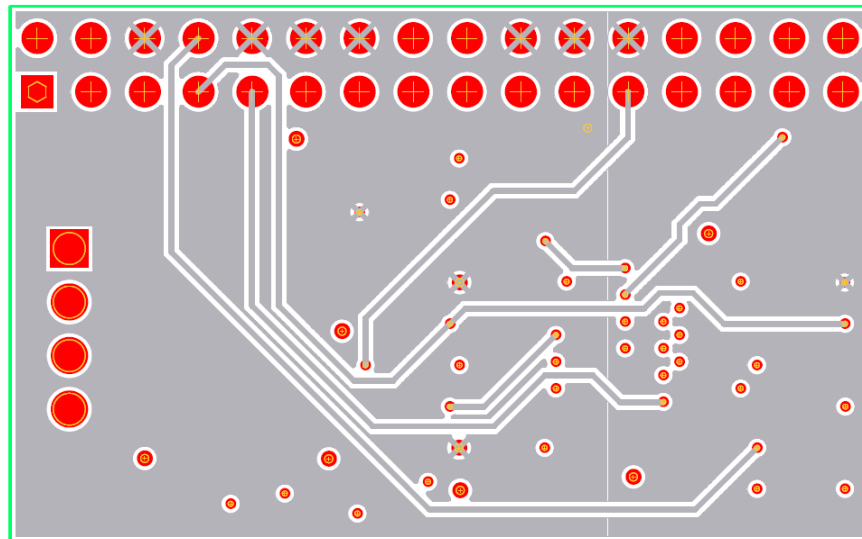

Figure 19 – inner layer2 layout

**APPENDIX X – BILL OF MATERIALS (MAIN BOARD)**

C1	0.47u, 250V	CAP 0.47uF 250/275 VAC +/-20%	Panasonic - ECG	ECQ-U2A474ML
C2	0.47u, 250V	CAP 0.47uF 250/275 VAC +/-20%	Panasonic - ECG	ECQ-U2A474ML
C3	DNP			
C4	DNP			
C5	68pF	CAP CER DISC 68pF 1KV SL 5% RAD	TDK Corp	CC45SL3AD680JYNN
C6	0.33u, 630V	CAP 0.33uF 630VDC METAL POLY	Panasonic - ECG	ECQ-E6334KF
C7	330u, 450V	CAP ALUM 330uF 450V 20% SNAP	Panasonic - ECG	EET-UQ2W331DA
C8	DNP			
C9	0.1u	SMD CAP 0.1uF 50V 10% X7R	Murata Elec	GRM21BR71H104KA01L
C10	4.7u	SMD CAP CER 4.7uF 25V 10% X5R	Murata Elec	GRM32RR61E475KC31L
C11	0.33u, 630V	CAP 0.33uF 630VDC METAL POLY	Panasonic - ECG	ECQ-E6334KF
C12	0.1u	SMD CAP 0.1uF 50V 10% X7R	Murata Elec	GRM21BR71H104KA01L
C13	22u	SMD CAP CER 22uF 16V Y5V	Taiyo Yuden	EMK325F226ZN-T
C14	100pF	SMD CAP CER 100pF 630V 5% COG	Murata Elec	GRM31A5C2J101JW01D
C15	100pF	SMD CAP CER 100pF 630V 5% COG	Murata Elec	GRM31A5C2J101JW01D
C16	1n	SMD CAP CER 1000pF 100V 10% X7R	AVX Corp	12101C102KAT2A
C17	1nF	SMD CAP 1000pF 50V 10% X7R	AVX Corp	08055C102KAT2A
C18	33pF	SMD CAP CERM 33pF 50V 5% NPO	AVX Corp	08055A330JAT2A
C19	33pF	SMD CAP CERM 33pF 50V 5% NPO	AVX Corp	08055A330JAT2A
C20	1n	SMD CAP CER 1000pF 50V 10% X7R	AVX Corp	08055C102KAT2A
C21	330u, 450V	CAP ALUM 330uF 450V 20% SNAP	Panasonic - ECG	EET-UQ2W331DA
C22	33pF	SMD CAP CERM 33pF 50V 5% NPO	AVX Corp	08055A330JAT2A
C23	1nF	SMD CAP CER 1000PF 1000V X7R	Kemet	C0805C102KDRACTU
C24	470pF	SMD CAP CER 470pF 200V X7R	Panasonic - ECG	ECJ-2VB2D471K
C25	100uF	SMD CAP TANT 100uF 25V 10%	Kemet	T491X107K025ZT
C26	470pF	SMD CAP CER 470pF 200V X7R	Panasonic - ECG	ECJ-2VB2D471K
C27	1uF	SMD CAP CER 1uF 50V 10% X5R	AVX Corp	08055D105KAT2A
C28	100uF	SMD CAP TANT 100uF 25V 10%	Kemet	T491X107K025ZT
C29	33pF	SMD CAP CERM 33pF 50V 5% NPO	AVX Corp	08055A330JAT2A
C30	68pF	CAP CER DISC 68pF 1KV SL 5% RAD	TDK Corp	CC45SL3AD680JYNN
D1	GBU806	RECT BRIDGE GPP 600V 8A GBU	Diodes Inc	GBU806
D2	8ETX06	DIODE HYPERFAST 600V 8A	Vishay	8ETX06PBF
D3	8EWS08S	DIODE STD REC 800V 8A SMD	Vishay	8EWS08S
D4	MB6S	IC RECT BRIDGE 0.5A 600V MBS-1	Micro Commercial	MB6S-TP
D5	1N4148	SMD DIODE SW 100V 150MA	Micro Commercial	1N4148W-TP
D6	DL4007	SMD RECT PASSIVATD 1A 1000V	Micro Commercial	DL4007-TP
D7	LED	SMD LED SUPPER RED CLEAR 75mA 1.7V	Chicago M L, LLC	CMD15-21SRC/TR8
D8	LED	SMD LED GREEN CLEAR 75mA 2.1V	Chicago M L LLC	CMD15-21VGC/TR8
D9	LED	SMD LED GREEN CLEAR 75mA 2.1V	Chicago M L LLC	CMD15-21VGC/TR8
D10	LED	SMD LED SUPPER RED CLEAR 75mA 1.7V	Chicago M L, LLC	CMD15-21SRC/TR8
D11	LED	SMD LED SUPPER RED CLEAR 75mA 1.7V	Chicago M L LLC	CMD15-21SRC/TR8

D12	DL4007	SMD RECT PASSIVATD 1A 1000V	Micro Commercial	DL4007-TP
D13	1N4148	SMD DIODE SW 100V 150MA	Micro Commercial	1N4148W-TP
D14	US1D	SMD DIODE ULTRA FAST SW 200V 1A	Diodes Inc	US1D-13-F
D15	8ETX06	DIODE HYPERFAST 600V 8A	Vishay	8ETX06PBF
D16	1N4148	SMD DIODE SW 100V 150MA	Micro Commercial	1N4148W-TP
D17	1N4148	SMD DIODE SW 100V 150MA	Micro Commercial	1N4148W-TP
D18	US1D	SMD DIODE ULTRA FAST SW 200V 1A	Diodes Inc	US1D-13-F
F1	10A	HOLDER PC FUSE 5mm LOW PROFILE	Keystone Elec	4527
K1	G6RL-1A-DC12	RELAY PWR SPST-NO 8A 12VDC PCB	Omron Elec	G6RL-1A DC12
L1	1.9mH	COMMON MODE LINE CHOKES 1.9mH	Coilcraft	CMT1-1.9-9L
L2	500U	INDUCTOR PFC 300W 820UHY	Precision INC	PFC-01102-00
L3	500U	INDUCTOR PFC 300W 820UHY	Precision INC	PFC-01102-00
MH1	P275RD125	SCREW 4-40 x 1/4 PHIL FLAT U/C SST		4C25PFUS
MH2	P275RD125	SCREW 4-40 x 1/4 PHIL FLAT U/C SST		4C25PFUS
MH3	P275RD125	SCREW 4-40 x 1/4 PHIL FLAT U/C SST		4C25PFUS
MH4	P275RD125	SCREW 4-40 x 1/4 PHIL FLAT U/C SST		4C25PFUS
MH5	P275RD125	SCREW 4-40 x 1/4 PHIL FLAT U/C SST		4C25PFUS
MH6	P275RD125	SCREW 4-40 x 1/4 PHIL FLAT U/C SST		4C25PFUS
Q1	SPW20N60C3	MOSFET N-CH 650V 20.7A	Infineon	SPW20N60C3
Q2	SPW20N60C3	MOSFET N-CH 650V 20.7A	Infineon	SPW20N60C3
Q3	2SK3018	MOSFET N-CH 30V 0.1A SOT-323	Rohm	2SK3018T106
RTD1	33k	THERMISTER NTC 33K OHM 5% RAD	EPCOS Inc	B57891M0333J000
R1	470k, 1W	RES 470K OHM METAL FILM 3W 5%	Vishay/BC	PR03000204703JAC00
R2	10k	SMD RES 10K OHM 3/4W 5%	Vishay/Dale	CRCW201010K0JNEF
R3	470k, 1W	RES 470K OHM METAL FILM 3W 5%	Vishay/BC	PR03000204703JAC00
R4	.08 OHM , 2W	SMD RES 0.08 OHM 2W 1% +/-75PPM	Vishay/Dale	WSL2816R0800FEH
R5	390, 1W	RES 390 OHM METAL FILM 1W 5%	Vishay/BC	PR01000103900JR500
R6	0	SMD RES 0.0 OHM 3/4W 5%	Vishay/Dale	CRCW20100000Z0EF
R7	DNP			
R8	10	SMD RES 10.0 OHM 1/8W 1%	Yageo	RC0805FR-0710RL
R9	0	SMD RES 0.0 OHM 3/4W 5%	Vishay/Dale	CRCW20100000Z0EF
R10	0	SMD RES 0.0 OHM 3/4W 5%	Vishay/Dale	541-0.0WCT-ND
R11	499k	SMD RES 499K OHM 3/4W 1%	Vishay/Dale	CRCW2010499KFKEF
R12	499k	SMD RES 499K OHM 3/4W 1%	Vishay/Dale	CRCW2010499KFKEF
R13	36.5k	SMD RES 36.5K OHM 1/2W 1%	Rohm	MCR50JZHF3652
R14	470k, 1W	RES 470K OHM METAL FILM 3W 5%	Vishay/BC	PR03000204703JAC00
R15	0	SMD RES 0.0 OHM 3/4W 5%	Vishay/Dale	CRCW20100000Z0EF
R16	470K	SMD RES 470K OHM 1/8W 1%	Panasonic - ECG	ERJ-6ENF4703V
R17	300 Ohm	SMD RES 300 OHM 1/8W 1%	Panasonic - ECG	ERJ-6ENF3000V
R18	499k	SMD RES 499K OHM 3/4W 1%	Vishay/Dale	CRCW2010499KFKEF
R19	499k	SMD RES 499K OHM 3/4W 1%	Vishay/Dale	CRCW2010499KFKEF
R20	36.5k	SMD RES 36.5K OHM 1/2W 1%	Rohm	MCR50JZHF3652
R21	499k	SMD RES 499K OHM 3/4W 1%	Vishay/Dale	CRCW2010499KFKEF

R22	25 Ohm	CURRENT LIMITER INRSR 25 OHM 20%	EPCOS Inc	B57238S0250M000
R23	2k2	SMD RES 2.20K OHM 1/8W 1%	Yageo	RC0805FR-072K2L
R24	2k2	SMD RES 2.20K OHM 1/8W 1%	Yageo	RC0805FR-072K2L
R25	2k2	SMD RES 2.20K OHM 1/8W 1%	Yageo	RC0805FR-072K2L
R26	499k	SMD RES 499K OHM 3/4W 1%	Vishay/Dale	CRCW2010499KFKEF
R27	10k	SMD RES 10.0K OHM 1/8W 1%	Yageo	RC0805FR-0710KL
R28	25m 3W	SMD RES 0.025 OHM 4W 1% +/-25PPM	Stackpole Elec	CSSH2728FT25L0
R29	10k	SMD RES 10K OHM 3/4W 5%	Vishay/Dale	CRCW201010K0JNEF
R30	390, 1W	RES 390 OHM METAL FILM 1W 5%	Vishay/BC	PR01000103900JR500
R31	499k	SMD RES 499K OHM 3/4W 1%	Vishay/Dale	CRCW2010499KFKEF
R32	2k2	SMD RES 2.20K OHM 1/8W 1%	Yageo	RC0805FR-072K2L
R33	499k	SMD RES 499K OHM 3/4W 1%	Vishay/Dale	CRCW2010499KFKEF
R34	36.5k	SMD RES 36.5K OHM 1/2W 1%	Rohm	MCR50JZHF3652
R35	5.1K	SMD RES 5.10K 1/8W 1%	Panasonic - ECG	ERJ-6ENF5101V
R36	47 Ohm	SMD RES 47.0 OHM 1/8W 1%	Panasonic - ECG	ERJ-6ENF47R0V
R37	DNP			
R38	48.2K	SMD RES 48.7K OHM 1/8W 1%	Panasonic - ECG	ERJ-6ENF4872V
R39	1k	SMD RES 1.00K OHM 1/8W 1%	Yageo	RC0805FR-071KL
R40	249k	SMD RES 249K OHM 3/4W 1%	Vishay/Dale	CRCW2010249KFKEF
R41	DNP			
R42	10	SMD RES 10.0 OHM 1/8W 1%	Yageo	RC0805FR-0710RL
R43	140k	SMD RES 140K OHM 3/4W 1%	Vishay/Dale	CRCW2010140KFKEF
R44	47 Ohm	SMD RES 47.0 OHM 1/8W 1%	Panasonic - ECG	ERJ-6ENF47R0V
R45	100	SMD RES 100 OHM 1/8W 1%	Yageo	RC0805FR-07100RL
R46	7.96K	SMD RES 8.06K OHM 1/8W 1%	Panasonic - ECG	ERJ-6ENF8061V
R47	5.1K	SMD RES 5.10K 1/8W 1%	Panasonic - ECG	ERJ-6ENF5101V
R48	5.1K	SMD RES 5.10K 1/8W 1%	Panasonic - ECG	ERJ-6ENF5101V
R49	100	SMD RES 100 OHM 1/8W 1%	Yageo	RC0805FR-07100RL
R50	10	SMD RES 10.0 OHM 3/4W 5%	Vishay/Dale	CRCW201010R0JNEF
R51	.08 OHM , 2W	SMD RES 0.08 OHM 2W 1% +/-75PPM	Vishay/Dale	WSL2816R0800FEH
SW1	SW-SPDT	SW SLIDE SPDT 30V 0.2A PC MNT	E-Switch	EG1218
T4	EE13	TRANSFORMER	Precision Inc	019-7086-00R
U1	ADP3634	IC DRIVER DUAL 4A NONINV	Analog Devices	ADP3634ARDZ
U5	LNK606	POWER INTEGRATIONS 5.5W 85-265VAC	Power Integrations	LNK606DG

**APPENDIX XI – BILL OF MATERIALS (DAUGHTER CARD)**

Part Reference	Part Description	Manufacture	Mfg Part No
C1	DNI		
C2	DNI		
C3	DNI		
C4	CAP CER 1000pF 50V 5% COG	Murata Electronics	GRM2165C1H102JA01D
C5	DNI		
C6	DNI		
C7	DNI		
C8	DNI		
C9	CAP CER 10uF 25V +/-20% X5R	Panasonic - ECG	ECJ-4YB1E106M
C10	CAP CER 0.1uF 50V 10% X7R	Murata Electronics	GRM21BR71H104KA01L
C11	CAP CER 1.0uF 50V 10% X7R	Murata Electronics	GRM32RR71H105KA01L
C12	CAP CER 0.1uF 50V 10% X7R	Murata Electronics	GRM21BR71H104KA01L
C13	CAP CER 0.1uF 50V 10% X7R	Murata Electronics	GRM21BR71H104KA01L
C14	DNI		
C15	DNI		
C16	DNI		
D1	DIODE SWITCH 100V 150MA	Micro Commercial	1N4148WTPMSCT-ND
D2	DIODE SWITCH 100V 150MA	Micro Commercial	1N4148WTPMSCT-ND
D6	LED SUPER RED CLEAR 75MA 1.7V SMD	CHICAGO MINIATURE LIGHTING	CMD15-21SRC/TR8
R1	RES 90.9K OHM 1/8W 1% SMD	Any	
R2	RES 10K OHM 1/8W 1% SMD	Any	
R3	RES 90.9K OHM 1/8W 1% SMD	Any	
R4	RES 10K OHM 1/8W 1% SMD	Any	
R5	RES 90.9K OHM 1/8W 1% SMD	Any	
R6	RES 10K OHM 1/8W 1% SMD	Any	
R7	RES 10K OHM 1/8W 0.1% SMD	Any	
R8	RES 10K OHM 1/8W 0.1% SMD	Any	
R9	RES 0.0 OHM 1/8W 5% SMD	Any	
R11	RES 49.9K OHM 1/8W 0.1% SMD	Any	
R12	RES 2.20K OHM 1/8W 1% SMD	Any	
R13	RES 0.0 OHM 1/8W 5% SMD	Any	
R14	RES 10K OHM 1/8W 1% SMD	Any	
R15	RES 10K OHM 1/8W 1% SMD	Any	
R16	RES 0.0 OHM 1/8W 5% SMD	Any	
R18	RES 2.20K OHM 1/8W 1% SMD	Any	
R19	RES 2.20K OHM 1/8W 1% SMD	Any	
R20	RES 2.20K OHM 1/8W 1% SMD	Any	
R21	RES 2.20K OHM 1/8W 1% SMD	Any	
R22	RES 0.0 OHM 1/8W 5% SMD	Any	
U1	Digital PFC Controller	Analog Devices	ADP1047
U2	Low Dropout Regulators	Analog Devices	ADP3303

**APPENDIX XII – REGISTER FILE (REVA\_IC REVISED-0408.48R)**

Reg(1 h) = 4h - OPERATION	Reg(FE11 h) = 0h - PWM2 rising edge setting
Reg(2 h) = 17h - ON_OFF_CONFIG	Reg(FE12 h) = 20h - PWM2 falling edge timing
Reg(10 h) = 0h - WRITE_PROTECT	Reg(FE13 h) = 3h - PWM2 falling edge setting
Reg(20 h) = 6h - VOUT_MODE	Reg(FE14 h) = 1h - PWM_Set
Reg(21 h) = 604h - VOUT_COMMAND	Reg(FE15 h) = 33h - PWM_Limit
Reg(29 h) = 80AAh - VOUT_SCALE_LOOP	Reg(FE18 h) = 83h - RTD_ADC_gain_Trim
Reg(2A h) = FB02h - VOUT_SCALE_MONITOR	Reg(FE19 h) = 0h - OT_FAULT_LIMIT
Reg(35 h) = F154h - VIN_ON	Reg(FE1A h) = 0h - OT_WARN_LIMIT
Reg(36 h) = F118h - VIN_OFF	Reg(FE1B h) = Dh - Switching frequency setting
Reg(40 h) = F708h - VOUT_OV_FAULT_Limit	Reg(FE1C h) = 0h - Low power switching frequency setting
Reg(41 h) = C0h - VOUT_OV_FAULT_RESPONSE	Reg(FE1D h) = 3h - Frequency dithering set
Reg(42 h) = F690h - VOUT_OV_WARN_LIMIT	Reg(FE1E h) = 0h - Frequency synchronization set
Reg(43 h) = F500h - VOUT_UV_WARN_LIMIT	Reg(FE20 h) = 28h - Voltage_Loop_Filter_Gain
Reg(44 h) = F320h - VOUT_UV_FAULT_LIMIT	Reg(FE21 h) = C0h - Voltage_Loop_Filter_Zero
Reg(45 h) = 58h - VOUT_UV_FAULT_RESPONSE	Reg(FE22 h) = 58h - Fast voltage loop filter gain
Reg(50 h) = 0h - OT_FAULT_RESPONSE	Reg(FE23 h) = F8h - Fast voltage loop filter zero
Reg(55 h) = F434h - VIN_OV_FAULT_LIMIT	Reg(FE24 h) = BBh - Fast voltage loop enable
Reg(56 h) = 0h - VIN_OV_FAULT_RESPONSE	Reg(FE25 h) = 4Ah - VAC_threshold_set
Reg(58 h) = F140h - VIN_UV_WARN_LIMIT	Reg(FE27 h) = 4Bh - MIN_AC_PERIOD_SET
Reg(59 h) = F118h - VIN_UV_FAULT_LIMIT	Reg(FE28 h) = 8Ah - MAX_AC_PERIOD_SET
Reg(5A h) = 78h - VIN_UV_FAULT_RESPONSE	Reg(FE29 h) = 32h - Current loop filter gain for low line input
Reg(5B h) = CA2Ah - IIN_OC_FAULT_LIMIT	Reg(FE2A h) = D7h - Current loop filter zero for low line input
Reg(5C h) = 0h - IIN_OC_FAULT_RESPONSE	Reg(FE2B h) = 5Ah - Current loop filter gain for high line input
Reg(5D h) = CA5Fh - IIN_OC_WARN_LIMIT_ADC	Reg(FE2C h) = AAh - Current loop filter zero for high line input
Reg(6B h) = F550h - PIN_OP_WARN_LIMIT	Reg(FE2D h) = 1Eh - Soft_Start_Set
Reg(FE00 h) = 0h - CS_Fast_OCP_Response	Reg(FE2E h) = 1h - INRUSH_Set
Reg(FE01 h) = 80h - VFB_Fast_OVP_Response	Reg(FE2F h) = 32h - VFB_OV_FAULT_RISE
Reg(FE02 h) = 0h - OLP_Response	Reg(FE30 h) = 3h - VFB_OV_FAULT_FALL
Reg(FE03 h) = 0h - VDD3P3_RESPONSE	Reg(FE31 h) = 2h - FAST_OVP_debounce_setting
Reg(FE04 h) = 0h - VCORE_RESPONSE	Reg(FE32 h) = 2Eh - Low power mode operation threshold
Reg(FE05 h) = 0h - PGOOD_AC_OK_DEBOUNCE_SET	Reg(FE35 h) = 4Dh - HIGH LINE LIMIT
Reg(FE06 h) = 0h - PSON_SET	Reg(FE36 h) = 41h - LOW LINE LIMIT
Reg(FE07 h) = 0h - Flag_Fault_ID	Reg(FE37 h) = 0h - Ilim_trim
Reg(FE08 h) = 1Bh - SoftStart_Flags_Blank_1	Reg(FE39 h) = 6B7h - EXPONENT
Reg(FE09 h) = 0h - SoftStart_Flags_Blank_2	Reg(FE3A h) = 3h - READ_UPD_RATE
Reg(FE0A h) = 0h - PGOOD_FLAGS_LIST	Reg(FE3B h) = FB02h - VIN_SCALE_MONITOR
Reg(FE0B h) = 0h - AC_OK_FLAGS_LIST	Reg(FE3C h) = DB20h - IIN_RSENSE
Reg(FE0C h) = 0h - PWM rising edge timing	Reg(FE3D h) = 1Fh - FAST_OCP_BLANK
Reg(FE0D h) = 0h - PWM rising edge setting	Reg(FE3E h) = E0h - CS_Fast_OCP_setting
Reg(FE0E h) = 20h - PWM falling edge timing	Reg(FE3F h) = 0h - Temperature hysteresis
Reg(FE0F h) = 3h - PWM falling edge setting	Reg(FE40 h) = 28h - VAC_ADC_gain_Trim
Reg(FE10 h) = 0h - PWM2 rising edge timing	



Reg(FE41 h) = 9h - VFB\_ADC\_gain\_Trim  
 Reg(FE42 h) = 81h - CS\_ADC\_gain\_Trim\_500mV\_range  
 Reg(FE43 h) = C0h - lbal gain  
 Reg(FE44 h) = 1Ah - SMTVOUT\_LOW\_POWER\_THRES  
 Reg(FE45 h) = C0h - SMTVOUT\_HIGH\_POWER\_THRES  
 Reg(FE46 h) = 457h - SMTVOUT\_LOW\_LINE\_VO1  
 Reg(FE47 h) = 4ACh - SMTVOUT\_LOW\_LINE\_VO2  
 Reg(FE48 h) = 479h - SMTVOUT\_High\_LINE\_VO1  
 Reg(FE49 h) = 4FEh - SMTVOUT\_High\_LINE\_VO2  
 Reg(FE4A h) = 4FEh - SMTVOUT\_UPLIMIT\_VOH  
 Reg(FE4B h) = 66Ah - SMTVOUT\_VAC\_240V  
 Reg(FE4C h) = 0h - SYNC\_DELAY  
 Reg(FE4D h) = 5Dh - SMTVOUT\_VAC\_240V\_HYS  
 Reg(FE4E h) = 9h - Power\_HYS  
 Reg(FE4F h) = 40h - ADVANCED\_FEUTURE\_ENABLE  
 Reg(FE50 h) = 0h - VOUT\_OV\_FAULT\_HYS  
 Reg(FE51 h) = 3Ch - VIN\_UV\_FAULT\_HYS  
 Reg(FE53 h) = 0h - VAC\_ADC\_offset\_Trim  
 Reg(FE54 h) = 0h - CS\_ADC\_offset\_Trim\_500mV\_range  
 Reg(FE7E h) = 3Ch - CS\_ADC\_GAIN\_TRIM\_750mV\_range  
 Reg(FE7F h) = 0h - CS\_ADC\_OFFSET\_TRIM\_750mV\_range  
 Reg(FE90 h) = 50h - Current loop filter gain for low line input and light load  
 Reg(FE91 h) = B4h - Current loop filter zero for low line input and light load  
 Reg(FE92 h) = 50h - Current loop filter gain for high line input and light load  
 Reg(FE93 h) = B4h - Current loop filter zero for high line input and light load  
 Reg(FE94 h) = 0h - Smart VOUT power reading  
 Reg(FE95 h) = 8h - IBAL configuration  
 Reg(FE94 h) = 0h - SMTOUT\_POWER\_AVE

## NOTES