

ENG. NO SDA-89143--2**

EDP NO.

SIMILAR ITEM

CAD FILE : S89143.S0

DO NOT SCALE DRAWING

- NOTE : MATERIALS :
- HOUSING : PBT , 30% GF, 94V-0
 - TERMINAL : BRASS, PLATING : AU OPTION (SEE P/N LEGEND)
IN CONTACT AREA, 2.54 μ m/ 100 μ in MIN. TIN/LEAD
IN SOLDER TAIL AREA, BOTH OVER 1.27 μ m/50 μ in MIN. NICKEL OVERALL.
 - SHELL : ALUMINUM KILLED STEEL,
PLATING : 5.10 μ m/200 μ in MIN. TIN OVER
1.27 μ m/50 μ in MIN. NICKEL OVERALL.

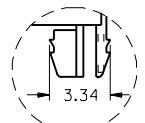

DETAIL "A"
SCALE : 4 : 1

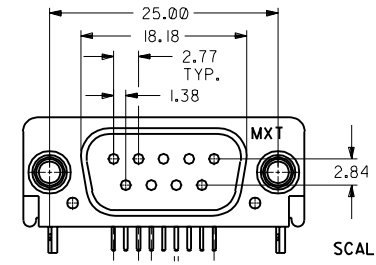

SCALE : 2 : 1

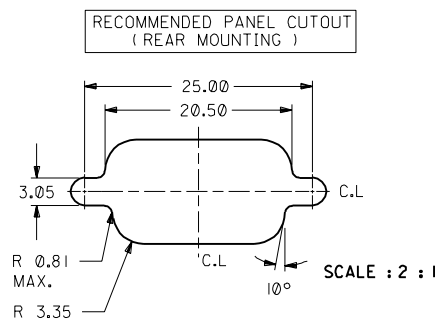

RECOMMENDED P.C BOARD LAYOUT

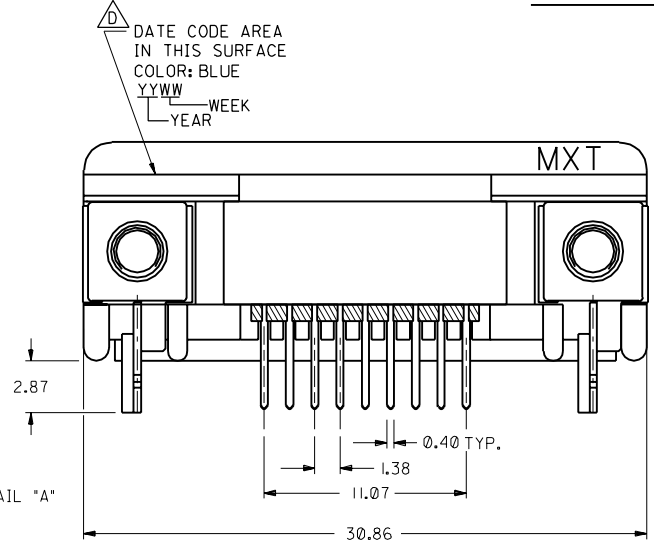
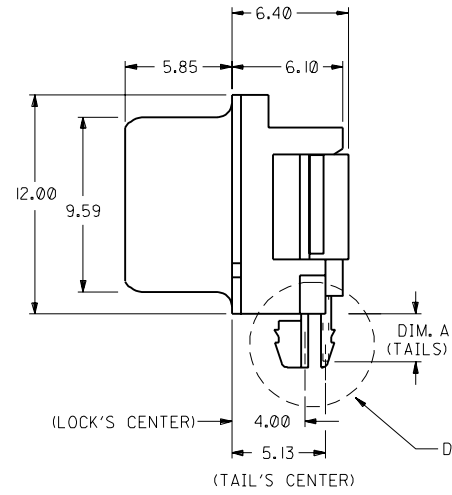

- LEGEND :**
- 89143-* 2 **
- HEX SCREW OPTION :
 - 1 - WITHOUT *4-40 SCREW
 - 3 - WITH 2 PCS *4-40 SCREW (NON-ASSEMBLED)
 - 5 - WITH 2 PCS *4-40 SCREW (P/N NO.82007-0300) (ASSEMBLED)
 - TERMINAL PLATING CODE :
 - 4 - 0.76 μ m/30 μ in AU MIN.
 - 5 - 0.38 μ m/15 μ in AU MIN.
 - 6 - AU FLASH
 - TAIL LENGTH AND HOUSING COLOR:
 - 1 - 2.6mm TAIL LENGTH , COLOR : BLACK
 - 2 - 2.1mm TAIL LENGTH , COLOR : BLACK
 - 3 - 1.6mm TAIL LENGTH , COLOR : BLACK

PRODUCT P/N	DIM. A (TAIL LENGTH)
89143-12**	2.6
89143-22**	2.1
89143-32**	1.6

				MATERIAL : SEE NOTE 1 & 2		MOLEX TAIWAN LTD. SHEET 1 OF 2
				FINISH : SEE NOTE 2 & 3		
				WIRE RANGE : _____		GENERAL TOLERANCES ANGLE : $\pm 3^\circ$ DIM : $\pm .25/0.10$
				INS. RANGE : _____		ENG. NO. : SDA-89143--2**
				DRAWN BY P.J. WANG 960215		REV D
				CHK'D BY		TITLE : 9 CKT, MALE STD. DIP TYPE D-SUB CONNECTOR (BACKCOVER AND LIF BOARD LOCK)
				APPR'D BY		SCALE 4 : 1
REVISE ONLY ON CAD SYSTEM						

ENG. NO SDA-89143-2

EDP NO.

SIMILAR ITEM

CAD FILE : S89143S2

DO NOT SCALE DRAWING

RECOMMENDED PC BOARD LAYOUT

TYPE A

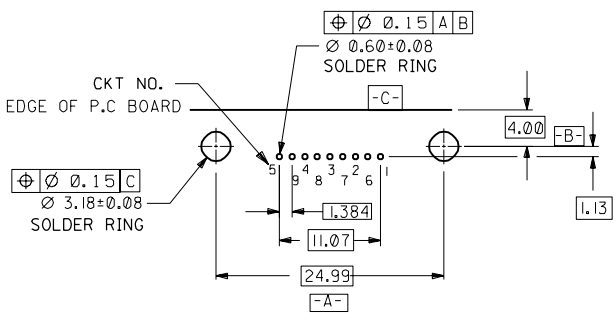

TYPE B

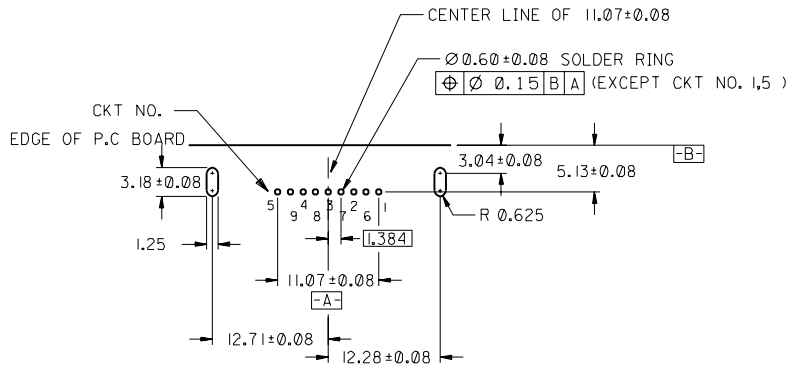

					MATERIAL : _____		MOLEX TAIWAN LTD. SHEET 2 OF 2	
					FINISH : _____			
					WIRE RANGE : _____		GENERAL TOLERANCES ANGLE : ± 3° DIM : ± .25 / .010	
C	ERROR CURRECTION	197-331	C.Wang	970327	INS. RANGE : _____		ENG. NO.:	
B	RELEASE TO MANUFACTURING	196-456	PJ	960521	INS. RANGE : _____		SDA-89143-2	
A1	TOOLING RELEASE	196-305	PJ	960214	INS. RANGE : _____		REV C	
LTR	REVISION RECORD	ECN	DR	DATE	DRAWN BY: J. WANG 960215	CHK'D BY	TITLE : 9 CKT, MALE STD. DIP TYPE D-SUB CONNECTOR (BACKCOVER AND LIF BOARD LOCK)	
REVISION RECORD					APPR'D BY	SCALE 2 : 1		