

THIS DRAWING IS UNPUBLISHED. RELEASED FOR PUBLICATION

© COPYRIGHT - By - ALL RIGHTS RESERVED.

REVISIONS

P	LTR	DESCRIPTION	DATE	DWN	APVD
B1		REVISED PER ECO-14-003208	18MAR2014	NK	DR
B2		REVISED PER ECO-17-008806	21FEB2018	RS	DR

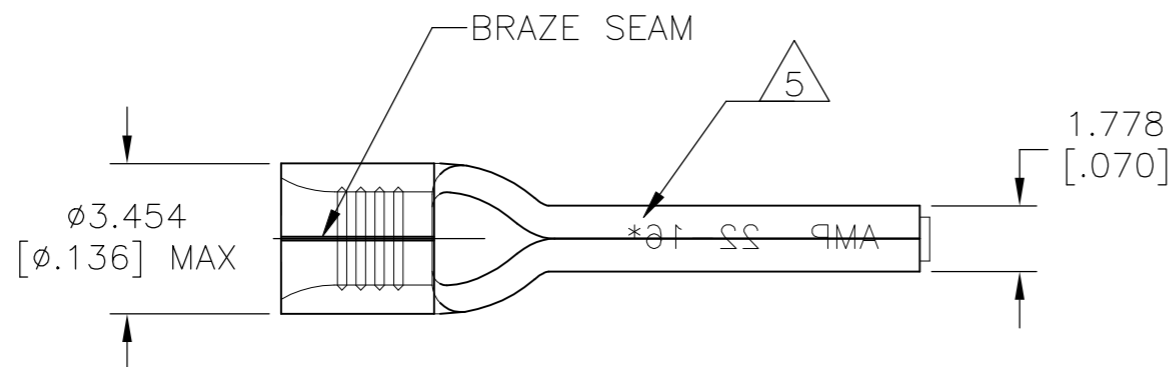

- 1 170°C [338°F] MAXIMUM OPERATING TEMPERATURE
- 2 MATERIAL 0.770±0.051 [0.030±0.002] THK
- 3 WIRE CROSS SECTIONAL AREA RANGE:
0.26-1.65mm² [509-3,260 CMA]
SOLID OR STRANDED
- 4 NOTE DELETED
- △ 5 STAMP AMP 22-16* APPROX AS SHOWN

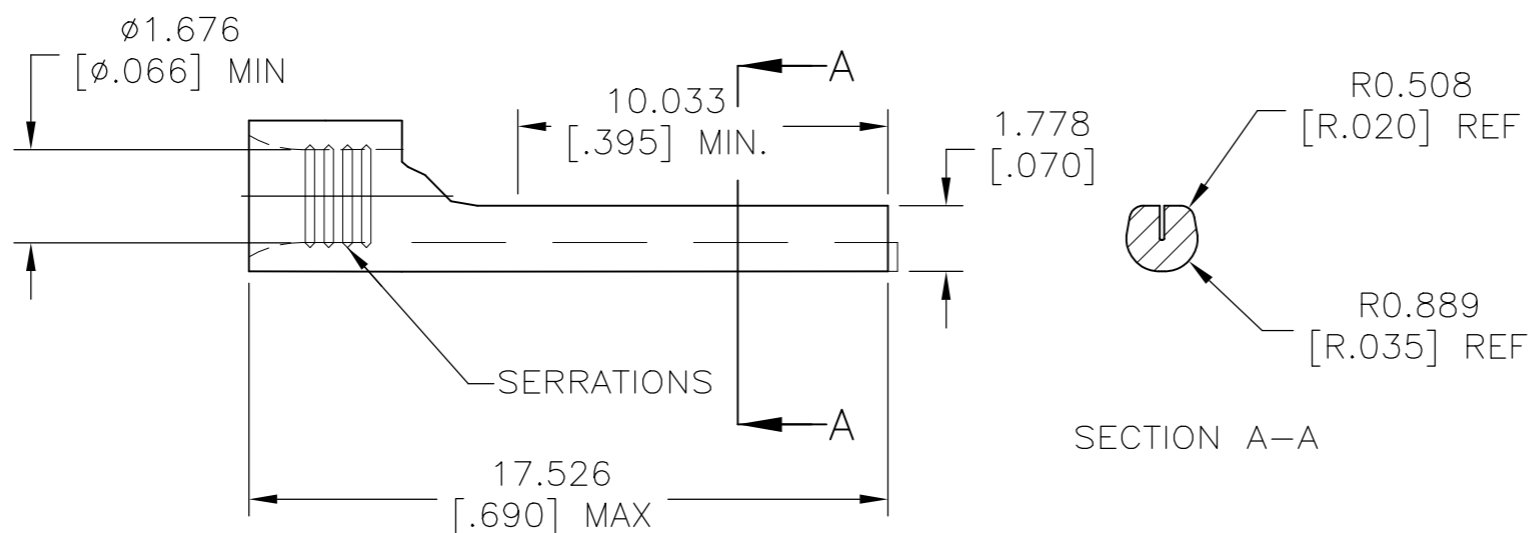

1000	LOOSE PIECE	TIN PLATED PER ASTM B-545 0.00254[.0001] MIN EXT THK	COPPER PER ASTM B-152, ANNEALED	165166
QTY	PACKAGING	FINISH	MATERIAL	PART NO

THIS DRAWING IS A CONTROLLED DOCUMENT.

DWN JR RUTH 04DEC08

CHK T MICHIELUTTI 04DEC08

APVD T MICHIELUTTI 04DEC08

PRODUCT SPEC

APPLICATION SPEC

WEIGHT

CUSTOMER DRAWING

STE TE Connectivity Ltd.

NAME
SOLISTRAND WIRE PIN (LONG)
22-16 AWG

SIZE	CAGE CODE	DRAWING NO	RESTRICTED TO
A3	00779	C-165166	-

DIMENSIONS:
mm [INCHES]

TOLERANCES UNLESS
OTHERWISE SPECIFIED:

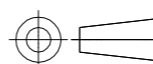

0 PLC	± -
1 PLC	± -
2 PLC	± -
3 PLC	± 0.127[.005]
4 PLC	± -
ANGLES	± -

MATERIAL FINISH

- -

SCALE 5:1 SHEET 1 OF 1 REV B2