

NOTE :

- MATERIAL : BODY : LCP UL94-V0  
: CONTACT : COPPER ALLOY.
- FOR PLATING PERFORMANCE REFER DRAWING # 101594.09
- CODING RECESS FOR 8MM EXTENDED KEYS
- PRODUCT MARKING = PRODUCT NUMBER + BATCH CODE + FCI  
FOR 2 MODULE SIZE, END OF PART NUMBER ONLY
- CENTRAL WALL WITH END REAR SUPPORT
- PACKAGING IN TRAY + COVER  
IF SUFFIX "P" IS ADDED IN P/N PACKAGING IS IN TRAYS  
BUT CONNECTOR MARKING IS WITHOUT "P"  
EXAMPLE: HM1XXXXXXXXXHyPLF, MARKED HM1XXXXXXXXXHyLF
- THE PRODUCTS WHERE THE PART NUMBER ENDS IN "LF" MEET THE EUROPEAN UNION DIRECTIVES AND OTHER COUNTRY REGULATIONS AS DESCRIBED IN GS-47-0004.
- ALL PRODUCTS WILL WITHSTAND EXPOSURE TO 260°C FOR 60 SECONDS IN A CONVECTION, INFAR-RED OR VAPOR PHASE REFLOW OVEN. AuCONTACT SURFACE OF THE CONTACT SHALL BE EXPOSED TO A MAXIMUM 140° C FOR NO LONGER THAN 15 SECONDS IN A WAVE SOLDER APPLICATION.

GENERAL CHARACTERISTICS AND ROHS INFORMATIONS:  
SEE PRODUCT SPECIFICATION GS-12-446

mat'l. code				surface ISO 1302 ✓		tolerance ISO 406 ISO 1101		projection mm		product family METRAL	
ltr				ecn no		dr		date		title	
F				-		CHA		2003-07-03		METRAL RA HDR WB CONVERGE 4X12 CTS - STB - PUSH PEG	
G				LS05-0056		MLE		2005-06-06		dwg no	
H				LS06-0097		LGO		2006-07-13		sheet 1 of 2	
J				LS07-0184		MLE		2007-07-24		size	
K				ELX-I-38109		MINI		2020-08-24		A3	
sheet index				revision sheet		K		1		type	
										Product Customer Drawing	



© 2016 AFCI

Amphenol  
FCI

B

A

1 | 2 | 3 | 4 | 5 | 6

TIN LEAD PART NUMBER

PART NUMBER / CONTACT LOADING						
DIM-P ±0.10				DIM-D ±0.3	P/N AND PERFORMANCE LEVEL	SP N°
ROW-A	ROW-B	ROW-C	ROW-D			
5.00	5.00	5.00	5.00	TABLE-2	HM1L42AxP000HyPLF	
5.75	5.75	5.75	5.75	TABLE-2	HM1L42LxP000HyPLF	
6.50	6.50	6.50	6.50	TABLE-2	HM1L42DxP000HyPLF	
6.50	5.00	5.00	5.00	TABLE-2	HM1L42BxP000HyPLF	
6.50	5.75	5.75	6.50	TABLE-2	HM1L42CxP000HyPLF	
5.00	5.00	6.50	5.00	TABLE-2	HM1L42ZxP110HyPLF	110
5.00	5.75	6.50	5.00	TABLE-2	HM1L42ZxP430HyPLF	430
5.00	5.75	5.00	5.00	TABLE-2	HM1L42ZxP448HyPLF	448
5.75	5.00	5.00	5.00	TABLE-2	HM1L42ZxP009HyPLF	009
5.75	6.50	5.75	5.00	TABLE-2	HM1L42ZxP424HyPLF	424
6.50	5.75	6.50	5.75	TABLE-2	HM1L42ZxP037HyPLF	037
6.50	5.75	5.00	5.75	TABLE-2	HM1L42ZxP102HyPLF	102
6.50	6.50	6.50	5.75	TABLE-2	HM1L42ZxP135HyPLF	135
6.50	5.75	5.75	5.75	TABLE-2	HM1L42ZxP369HyPLF	369
8.00	6.50	5.75	6.50	3.70	HM1L42ZBP326HyPLF	326

y -Ref: Plating Code DWG :1015409

DIM-D=2.9 / replace 'x' by 'A' in the P/N

DIM-D=3.7 / replace 'x' by 'B' in the P/N

DETAIL OF LOCATING PEGS (2x)  
SCALE 8:1

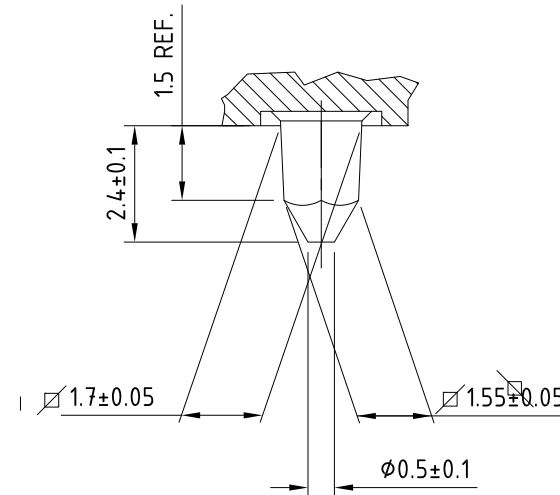

DETAIL OF CENTRAL PEG  
SCALE 8:1

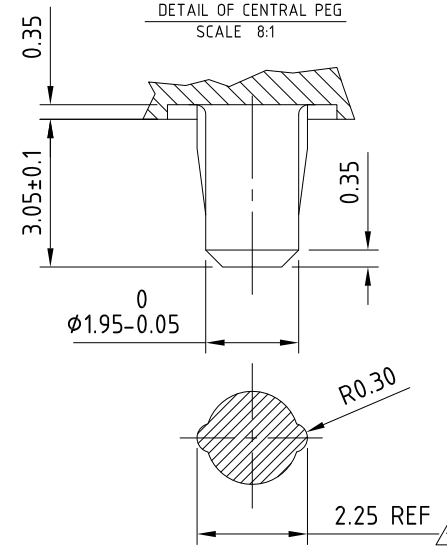

mat'l. code				surface ISO 1302 ✓		tolerance ISO 406 ISO 1101		projection 		product family METRAL					
ltr				ecn no		dr		date		title					
F				-		CHA		2003-07-03		METRAL RA HDR WB CONVERGE 4X12 CTS - STB - PUSH PEG					
G				LS05-0056		MLE		2005-06-06							
H				LS06-0097		LGO		2006-07-13							
J				LS07-0184		MLE		2007-07-24		dr		CHAMPION		1994-09-09	
K				ELX-I-38109		MINI		2020-08-24		enr		ARUN		2020-08-24	
										chr		ALEX BABU		2020-08-24	
										appd		SAN0J		2020-08-24	
sheet index		revision sheet		K		2									

