



SANYO Semiconductors

DATA SHEET

An ON Semiconductor Company

STK672-740B-E — Thick-Film Hybrid IC 2-phase Stepping Motor Driver

Overview

The STK672-740B-E is a hybrid IC for use as a unipolar, 2-phase stepping motor driver with PWM current control.

Applications

- Office photocopiers, printers, etc.

Features

- Built-in motor terminal open detection function (output current OFF).
- Built-in overcurrent detection function (output current OFF).
- Built-in overheat detection function (output current OFF).
- FAULT1 signal (active low) is output when any of motor terminal open, overcurrent, or overheat is detected. The FAULT2 signal is used to output the result of activation of protection circuit detection at 3 levels.
- Built-in power on reset function.
- Phase signal input driver activated with an active Low and incorporates a simultaneous ON prevention function.
- Supports schmitt input for 2.5V high level input.
- Incorporating a current detection resistor (0.089Ω: resistor tolerance $\pm 2\%$), motor current can be set using two external resistors.
- Provides the output current cutoff ENABLE pin.

■ Any and all SANYO Semiconductor Co.,Ltd. products described or contained herein are, with regard to "standard application", intended for the use as general electronics equipment (home appliances, AV equipment, communication device, office equipment, industrial equipment etc.). The products mentioned herein shall not be intended for use for any "special application" (medical equipment whose purpose is to sustain life, aerospace instrument, nuclear control device, burning appliances, transportation machine, traffic signal system, safety equipment etc.) that shall require extremely high level of reliability and can directly threaten human lives in case of failure or malfunction of the product or may cause harm to human bodies, nor shall they grant any guarantee thereof. If you should intend to use our products for applications outside the standard applications of our customer who is considering such use and/or outside the scope of our intended standard applications, please consult with us prior to the intended use. If there is no consultation or inquiry before the intended use, our customer shall be solely responsible for the use.

■ Specifications of any and all SANYO Semiconductor Co.,Ltd. products described or contained herein stipulate the performance, characteristics, and functions of the described products in the independent state, and are not guarantees of the performance, characteristics, and functions of the described products as mounted in the customer's products or equipment. To verify symptoms and states that cannot be evaluated in an independent device, the customer should always evaluate and test devices mounted in the customer's products or equipment.

SANYO Semiconductor Co., Ltd.

<http://semicon.sanyo.com/en/network>

STK672-740B-E

Specifications

Absolute Maximum Ratings at $T_c = 25^\circ\text{C}$

Parameter	Symbol	Conditions	Ratings	unit
Maximum supply voltage 1	V_{CC} max	No signal	50	V
Maximum supply voltage 2	V_{DD} max	No signal	-0.3 to +6.0	V
Input voltage	V_{IN} max	Logic input pins	-0.3 to +6.0	V
Output current 1	I_{OP} max	10 μ s, 1 pulse (resistance load)	20	A
Output current 2	I_{OH} max	$V_{DD}=5\text{V}$, $\text{CLOCK}\geq 200\text{Hz}$	4	A
Output current 3	I_{OF} max	Pin16 output current	10	mA
Allowable power dissipation 1	P_{dMF} max	With an arbitrarily large heat sink. Per MOSFET	8.3	W
Allowable power dissipation 2	P_{dPK} max	No heat sink	3.1	W
Operating substrate temperature	T_c	Metal surface temperature of the package	-20 to +105	$^\circ\text{C}$
Junction temperature	T_j max		150	$^\circ\text{C}$
Storage temperature	T_{stg}		-40 to +125	$^\circ\text{C}$

Allowable Operating Ranges at $T_a=25^\circ\text{C}$

Parameter	Symbol	Conditions	Ratings	unit
Operating supply voltage 1	V_{CC}	With signals applied	0 to 46	V
Operating supply voltage 2	V_{DD}	With signals applied	5 \pm 5%	V
Input high voltage	V_{IH}	Pins 13, 17, 12, 10, 14, 15	2.5 to V_{DD}	V
Input low voltage	V_{IL}	Pins 13, 17, 12, 10, 14, 15	0 to 0.8	V
Output current 1	I_{OH1}	$T_c=105^\circ\text{C}$, $\text{CLOCK}\geq 200\text{Hz}$, Continuous operation, duty=100%	3.0	A
Output current 2	I_{OH2}	$T_c=80^\circ\text{C}$, $\text{CLOCK}\geq 200\text{Hz}$, Continuous operation, duty=100%, See the motor current (I_{OH}) derating curve	3.3	A
Recommended Vref range	Vref		0.14 to 1.31	V

(* $\text{CLOCK} \geq 200\text{Hz}$ is the same as 200pps or more.)

Electrical Characteristics at $T_c=25^\circ\text{C}$, $V_{CC}=24\text{V}$, $V_{DD}=5.0\text{V}$

Parameter	Symbol	Conditions	min	typ	max	unit
V_{DD} supply current	I_{CCO}	Pin 9 current		5	8	mA
Output average current	I_{oave}	$R/L=1\Omega/0.62\text{mH}$ in each phase	0.519	0.625	0.731	A
FET diode forward voltage	Vdf	$I_f=1\text{A}$ ($R_L=23\Omega$)		0.83	1.5	V
Output saturation voltage	V_{sat}	$R_L=23\Omega$		0.20	0.33	V
Input high voltage	V_{IH}	Pins 13, 17, 12, 10, 14, 15	2.5			V
Input low voltage	V_{IL}	Pins 13, 17, 12, 10, 14, 15			0.8	V
FAULT1 low output voltage	V_{OLF}	Pin 16 ($I_O=5\text{mA}$)		0.25	0.5	V
5V level FAULT1 leakage current	I_{ILF}	Pin 16=5V			10	μA
FAULT2 Motor terminal open detection output voltage	V_{OF1}	Pin 8 (when all protection functions have been activated)	0.00	0.01	0.20	V
FAULT2 Overcurrent detection output voltage	V_{OF2}		2.4	2.5	2.6	
FAULT2 Overheat detection output voltage	V_{OF3}		3.1	3.3	3.5	
5V level input current	I_{ILH}	Pins 13, 17, 12, 10, 14, 15=5V		50	75	μA
GND level input current	I_{ILL}	Pins 13, 17, 12, 10, 14, 15=GND			10	μA
Vref input bias current	I_{IB}	Pin 19=1.0V			1	μA
PWM frequency	f_c		29	45	61	kHz
Overheat detection temperature	TSD	Design guarantee		144		$^\circ\text{C}$
Drain-source cut-off current	I_{DSS}	$V_{DS}=100\text{V}$, Pins 2, 6, 9, 18=GND			1	μA

* Operation at the maximum V_{CC} value may not be possible, depending on the motor current. See "8. Other Notes on Use" in the Data Sheet for details.

* I_{oave} values are for when the lead frame of the product is soldered to the mounting substrate.

Notes: A fixed-voltage power supply must be used.

STK672-740B-E

Package Dimensions

unit:mm (typ)

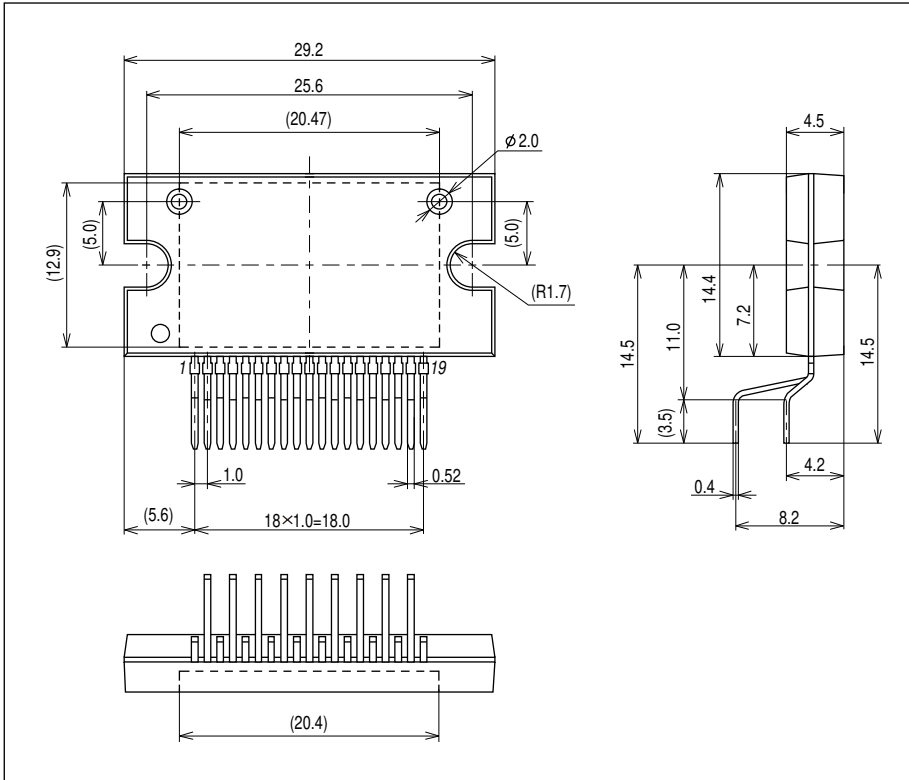

Derating curve of motor current, I_{OH} , vs. STK672-740B-E Operating substrate temperature, T_c

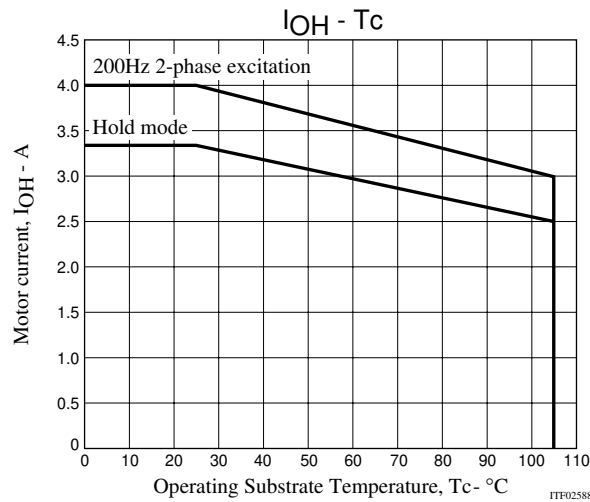

Notes

- The current range given above represents conditions when output voltage is not in the avalanche state. If the output voltage is in the avalanche state, see the allowable avalanche energy for STK672-7** series hybrid ICs given in a separate document.
- The operating substrate temperature, T_c , given above is measured while the motor is operating. Because T_c varies depending on the ambient temperature, T_a , the value of I_{OH} , and the continuous or intermittent operation of I_{OH} , always verify this value using an actual set.
- The T_c temperature should be checked in the center of the metal surface of the product package.

STK672-740B-E

Block Diagram

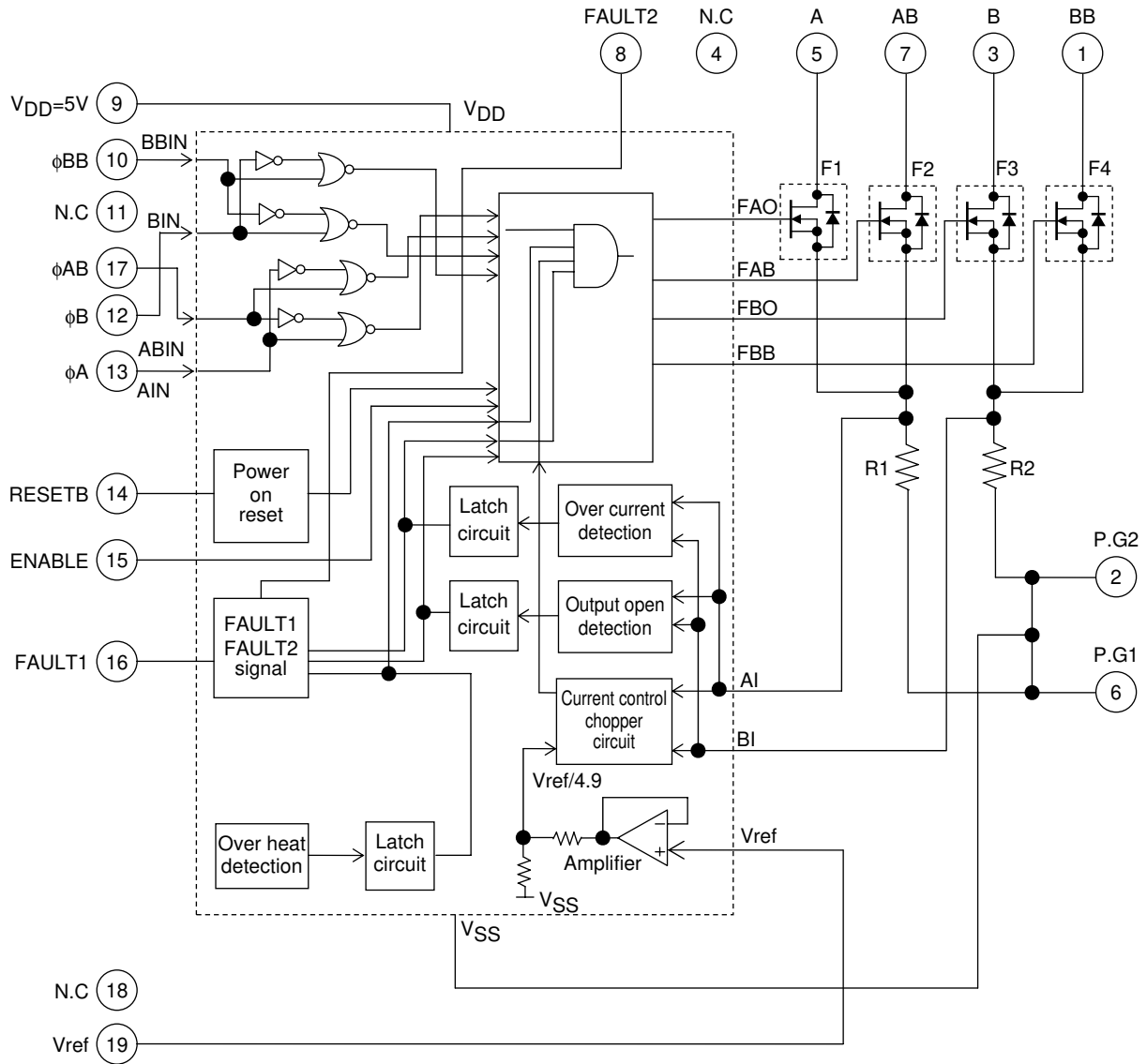

Sample Application Circuit

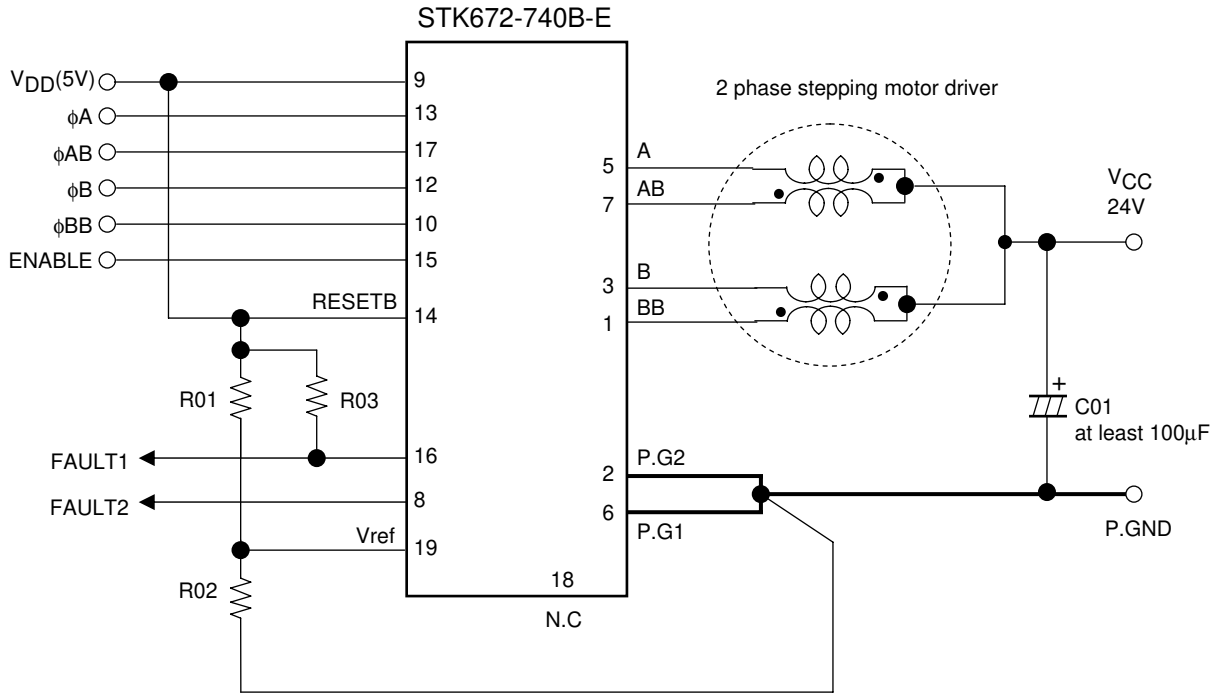

Precautions

[GND wiring]

- To reduce noise on the 5V system, be sure to place the GND of C01 in the circuit given above as close as possible to Pin 2 and Pin 6 of the hybrid IC. Also, to achieve accurate current settings, be sure to connect Vref GND to the point where P.G1 and P.G2 share a connection.

[Input pins]

- If VDD is being applied, use care that each input pin does not apply a negative voltage less than -0.3V to P.GND, and do not apply a voltage greater than or equal to VDD voltage.
- Do not wire by connecting the circuit pattern on the P.C.B side to Pin 4, 11, or 18 on the N.C. shown in the internal block diagram.
- Apply 2.5V high level input to pins 13, 17, 12, 10, 14, and 15.
- Since the input pins do not have built-in pull-up resistors, when the open-collector type pins 13, 17, 12, 10, 14, and 15 are used as inputs, a 1 to 20kΩ pull-up resistor (to VDD) must be used. At this time, use a device for the open collector driver that has output current specifications that pull the voltage down to less than 0.8V at Low level (less than 0.8V at Low level when IOL=5mA).

[Current setting Vref]

If the motor current is temporarily reduced, the circuit given below (STK672-740B-E : IOH>0.3A) is recommended.

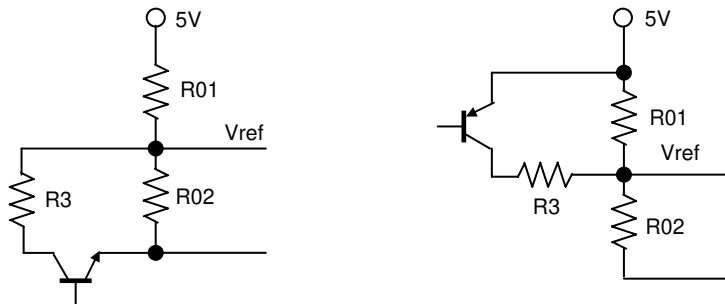

• Motor current peak value I_{OH} setting

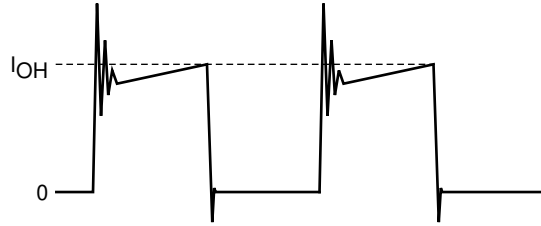

$$I_{OH} = (V_{ref} \div 4.9) \div R_s$$

The value of 4.9 in Equation above represents the V_{ref} voltage as divided by a circuit inside the control IC.

$$V_{ref} = (R02 \div (R01 + R02)) \times 5V \text{ (or } 3.3V)$$

R_s is an internal current detection resistor value of the hybrid IC.

$R_s = 0.089\Omega$ when using the STK672-740B-E

Input Pin Functions

Pin Name	Pin No.	Function	Input Conditions When Operating
ϕA	13	Pin 5, phase A output	Low active (with a function to prevent simultaneous ON of ϕA and ϕAB , or ϕB and ϕBB)
ϕAB	17	Pin 7, phase AB output	
ϕB	12	Pin 3, phase B output	
ϕBB	10	Pin 1, phase BB output	
RESETB	14	System reset	A reset is applied by a low level
ENABLE	15	A, AB, B, and, BB outputs cut off	A, AB, B, and BB outputs are cut off by a low level

Output Pin Functions

Pin Name	Pin No.	Function	Input Conditions When Operating
FAULT1	16	Monitor pin when any of motor terminal open, overcurrent, or overheat is detected.	Low level is output when detected.
FAULT2	8	Monitor pin used when over-current detection or overheat detection function is activated.	3 levels output

Note: See the timing chart for the concrete details on circuit operation.

Timing Charts

2-phase excitation

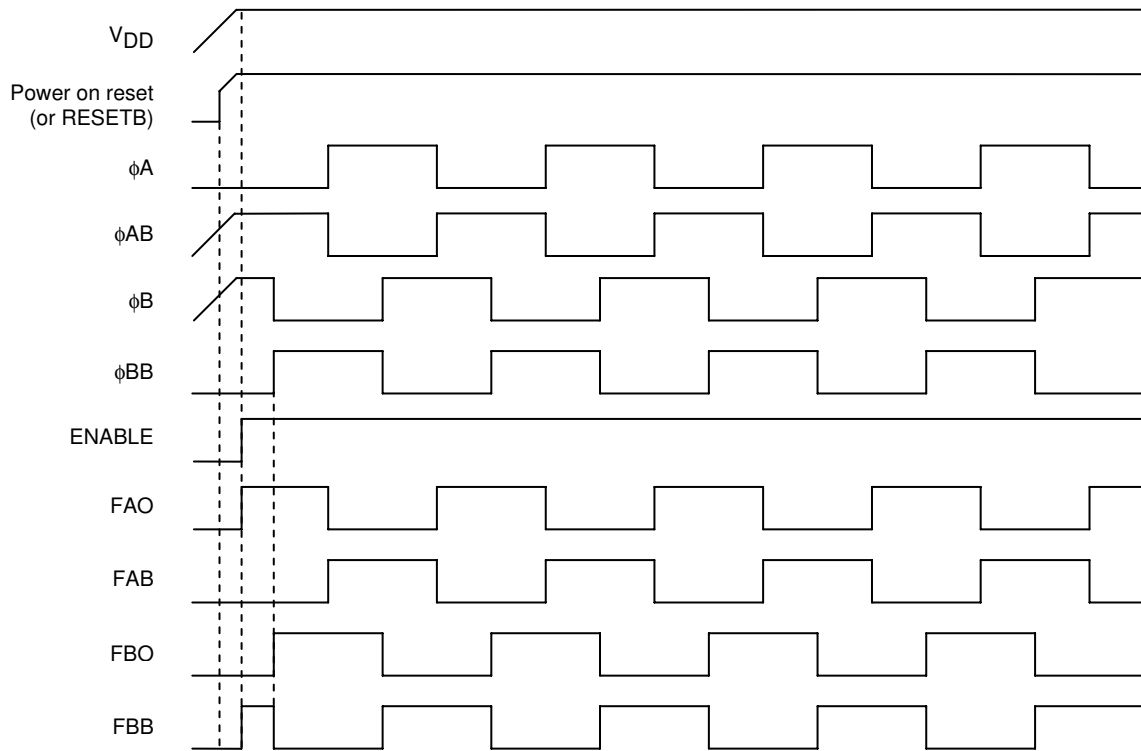

1-2 phase excitation

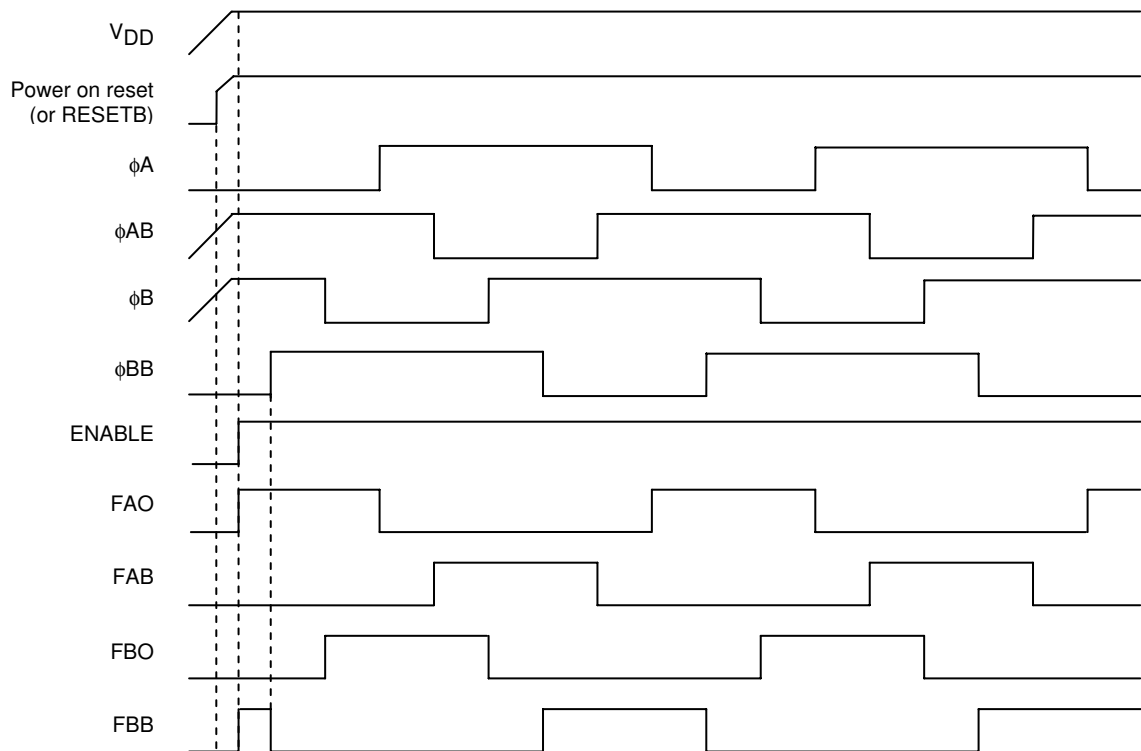

STK672-740B-E

1-2 phase excitation (ENABLE)

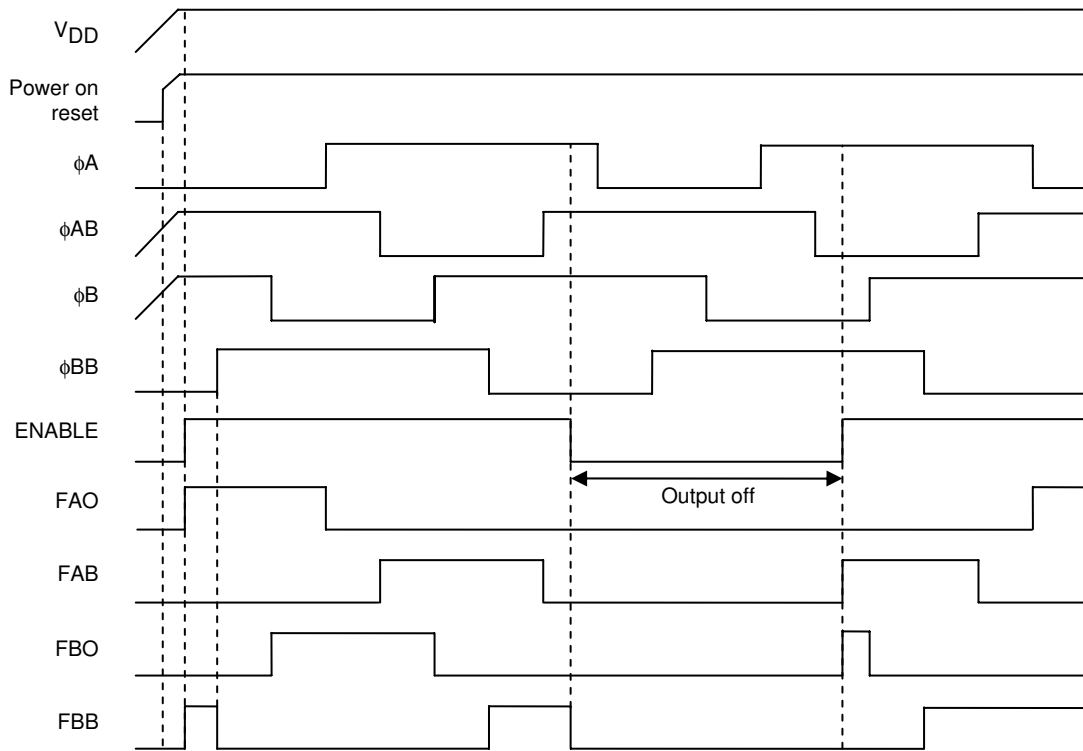

1-2 phase excitation (Hold operation results during fixed CLOCK)

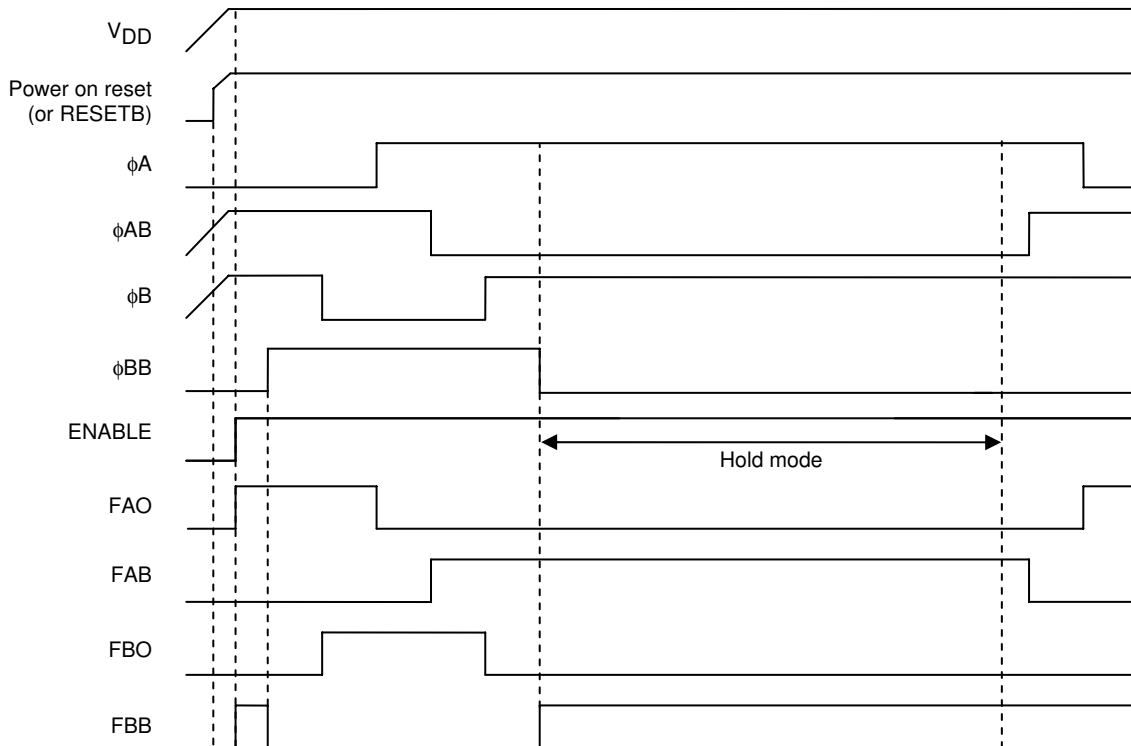

Usage Notes

1. STK672-740B-E Input signal functions and timing

[ENABLE, power on reset, and RESETB (Input signal timing when power is first applied)]

The control IC of the driver is equipped with a power on reset function capable of initializing internal IC operations when power is supplied. A 4V typ setting is used for power on reset. Because the specification for the MOSFET gate voltage is $5V \pm 5\%$, conduction of current to output at the time of power on reset adds electromotive stress to the MOSFET due to lack of gate voltage. To prevent electromotive stress, be sure to set ENABLE=Low while V_{DD} , which is outside the operating supply voltage, is less than 4.75V.

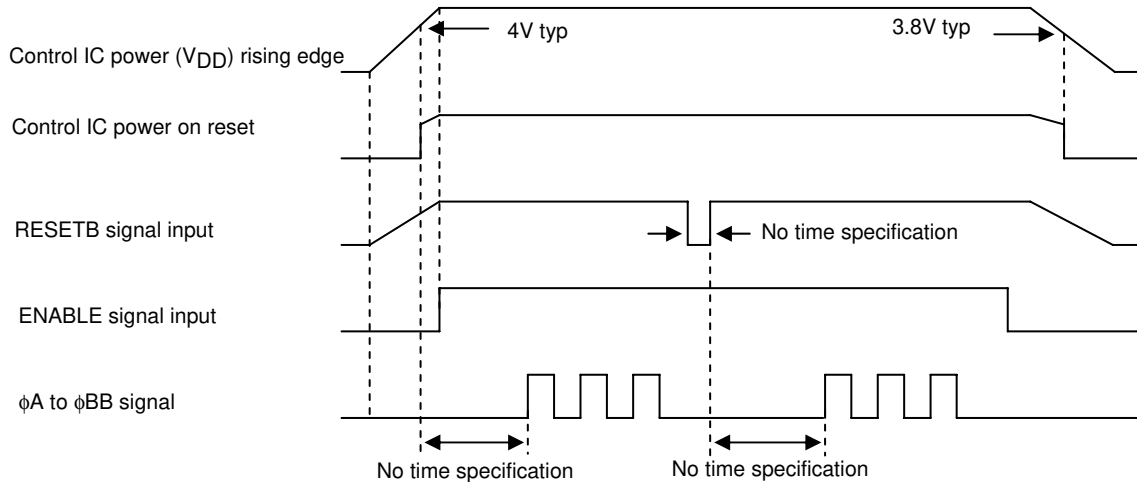

ENABLE, ϕA to ϕBB Signals Input Timing

[ENABLE (Forcible on/off control of the A, AB, B, and BB outputs, and hybrid IC internal operation)]

ENABLE=1: Normal operation

ENABLE=0: Outputs A, AB, B, and BB forced to the off state.

If the ϕA to ϕBB signal used for motor rotation suddenly stops, the motor shaft may advance beyond the control position due to inertia. A SLOW DOWN setting where the ϕA to ϕBB cycle gradually decreases is required in order to stop at the control position.

STK672-740B-E

[Configuration of Each Input Pin]

<Configuration of the ϕA , ϕAB , ϕB , ϕBB , ENABLE, and RESETB input pins>

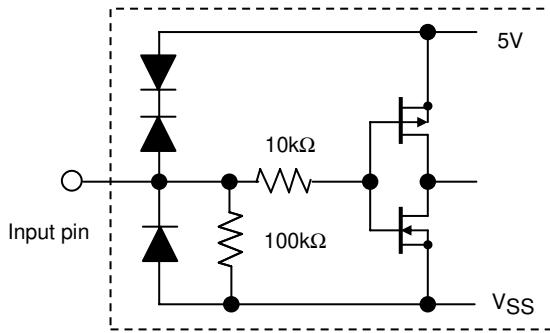

<Configuration of the FAULT2 pin>

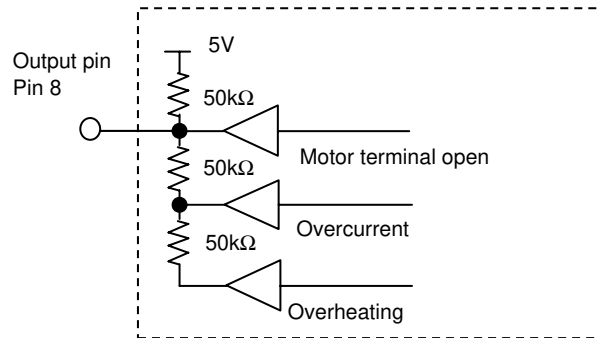

(The buffer has an open drain configuration.)

All input pins of this driver support schmitt input. Typ specifications at $T_c = 25^\circ\text{C}$ are given below. Hysteresis voltage is 0.3V ($V_{IHa} - V_{ILa}$).

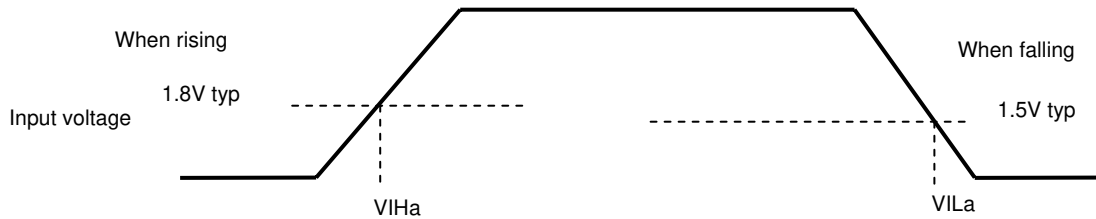

Input voltage specifications are as follows.

$V_{IH} = 2.5\text{V min}$

$V_{IL} = 0.8\text{V max}$

<Configuration of the Vref input pin>

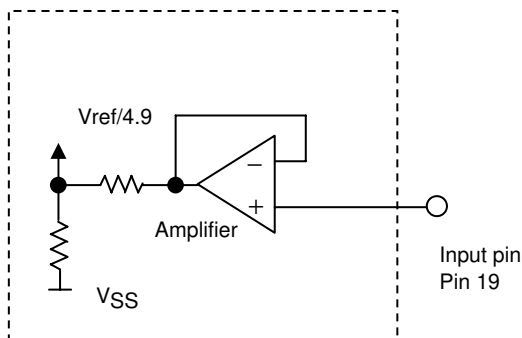

<Configuration of the FAULT1 output pin>

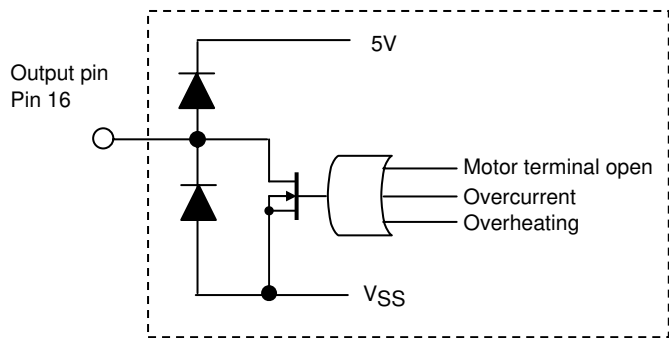

<FAULT1, FAULT2 output>

FAULT1 Output

FAULT1 is an open drain output. It outputs low level when any of motor terminal open, overcurrent, or overheat is detected.

FAULT2 output

Output is resistance divided (3 levels) and the type of abnormality detected is converted to the corresponding output voltage.

- Motor terminal open: 10mV (typ)
- Overcurrent: 2.5V (typ)
- Overheat: 3.3V (typ)

Abnormality detection can be released by a RESETB operation or turning V_{DD} voltage on/off.

2. STK672-740B-E overcurrent detection, overheat detection, and motor terminal open detection functions

Each detection function operates using a latch system and turns output off. Because a RESET signal is required to restore output operations, once the power supply, V_{DD}, is turned off, you must either again apply power on reset with V_{DDON} or apply a RESETB=High→Low→High signal.

[Motor terminal open detection]

This hybrid IC is equipped with a function for detecting open output terminals to prevent thermal destruction of the MOSFET due to repeated avalanche operation that occurs when an output terminal connected to the motor is open. The open condition is determined by checking the presence or absence of the flyback current that flows in the motor inductance during the off period of the PWM cycle.

Detection is performed by using the fact that the flyback current does not flow when a motor terminal is open.

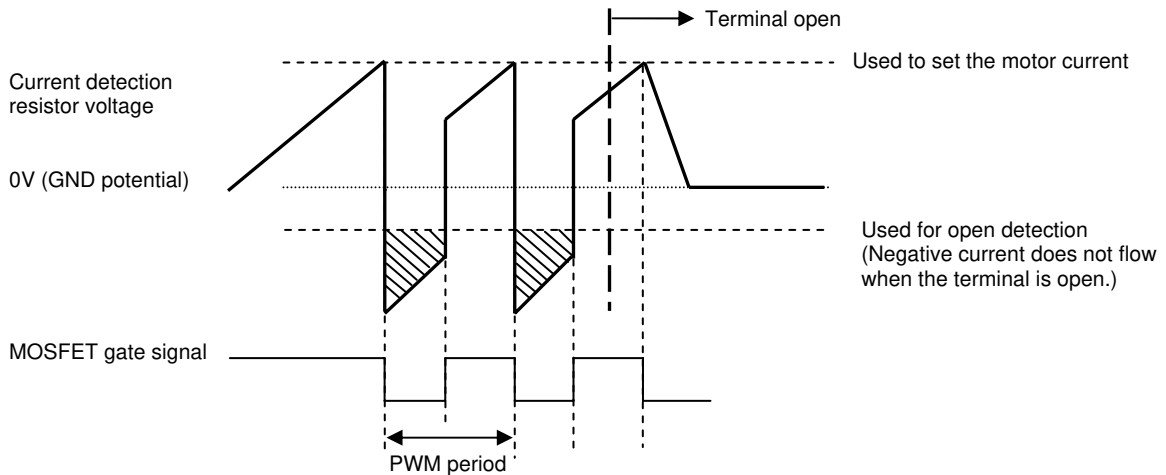

When the current level drops, the difference with the GND potential decreases, making detection difficult. The motor current that can be detected by motor terminal open detection is 1.1A or more with the STK672-740B-E.

<Notes on the ENABLE high edge>

When ENABLE changes from low to high and the STK672-7XXB-E performs constant-current PWM operation that flows a negative current during the 30μs period after the high edge, open detection may activate and stop the driver.

The motor current setting voltage V_{ref} must be set so that PWM operation is not performed within a period of 30μs after the high edge.

If the motor current setup voltage is set for the rated motor current, PWM operation is not performed during this 30μs period after the high edge, so this is not a problem.

In addition, there is no problem with operation that lowers the current setting V_{ref} after the motor rated current is reached as shown in the diagram on the following page.

Whether constant-current PWM operation is performed during the 30μs period after the high edge can be judged by substituting the motor L and R values into the formula on the following page.

$$V_{ref} = (R02 \div (R01 + R02)) \times 5V \text{ (or } 3.3V)$$

$$I_{OH1} = (V_{ref} \div 4.9) \div R_s \quad I_{OH1}: \text{ Motor current value to be set}$$

$$I_{OH2} = (V_{CC} \div R) \times (1 - e^{-tR/L}) \quad I_{OH2}: \text{ Current value } 30\mu\text{s after the ENABLE high edge}$$

$$\Rightarrow \text{Judgment standard: } I_{OH1} > I_{OH2}$$

R01, R02, 5V (or 3.3V): See the Sample Application Circuit documents.

R_s: Current detection resistance value (Ω)

V_{CC}: Motor supply voltage (V)

R: Motor winding resistance (Ω)

L: Motor winding inductance (H)

⇒ There is no problem if the I_{OH2} obtained by substituting t = 30μs and the motor L and R values is smaller than the current setting value I_{OH1}.

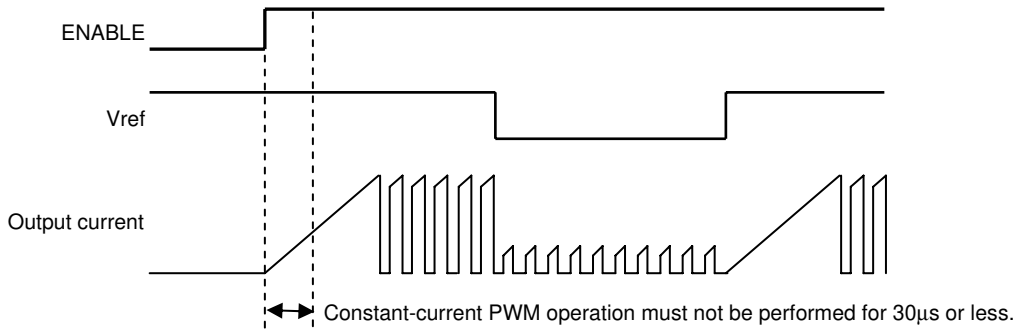

<Connection of capacitors between output pins and GND prohibited>

Capacitors must not be connected between the phase A (pin 5), phase AB (pin 7), phase B (pin 3) and phase BB (pin 1) outputs and GND. What happens if capacitors are connected is that open-circuit detection may be triggered by the discharge current of the capacitors when the internal MOSFET is set ON. This current is not an inductance current generated by the motor winding but a capacitor current so a negative current will not flow to the other phase in each pair of phases, possibly causing the driver to shut down.

<Excessive external noise>

If, when the motor current rises prior to the PWM operation, a spike-shaped current exceeding the Vref-setting current is generated by excessive external noise, for instance, before the current level (1.1A for the STK672-740B-E motor driver) at which motor pin open-circuiting can be detected is reached, the internal MOSFET is set OFF. Since the MOSFET has been set OFF before the actual motor current reaches 1.1A, the level of the negative current subsequently flowing to the other phase in each pair of phases is low, and it may be judged that no negative current is flowing, possibly causing open-circuit detection to be triggered.

During normal constant-current PWM operation, the duration of 5.5µs, which is equivalent to 25% of the initial operation in the PWM period, corresponds to the section where the current is not detected, and this ensures that no current is detected for the linking part of the current that is generated in this section. The no-current detection section is not synchronized at the current rise prior to the PWM operation so when a spike-shaped current exceeding the Vref-setting current is generated, the MOSFET is set OFF at the stage where the level of the actual motor current is low. As a result, the level of the negative current subsequently flowing to the other phase in each pair of phases is low, and it may be judged that no negative current is flowing, possibly causing open-circuit detection to be triggered.

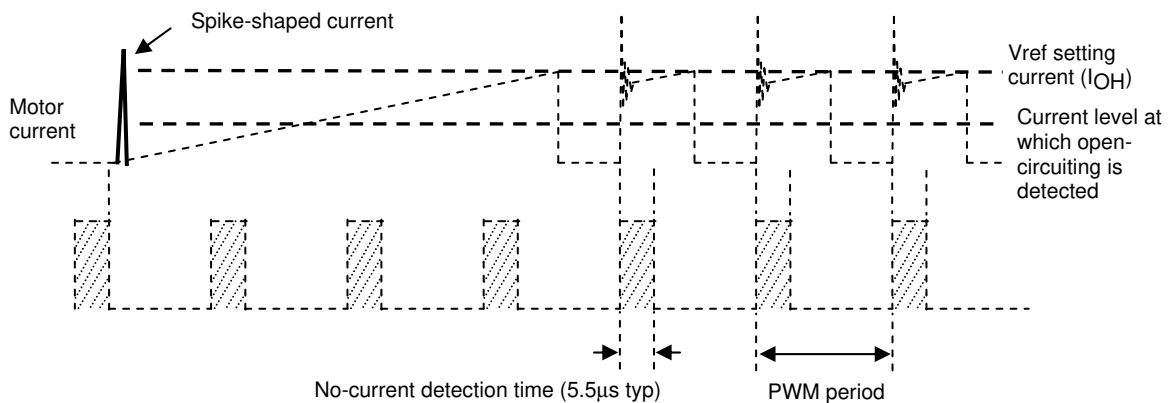

[Overcurrent detection]

This hybrid IC is equipped with a function for detecting overcurrent that arises when the motor burns out or when there is a short between the motor terminals.

Overcurrent detection occurs at 5.5A typ with the STK672-740B-E

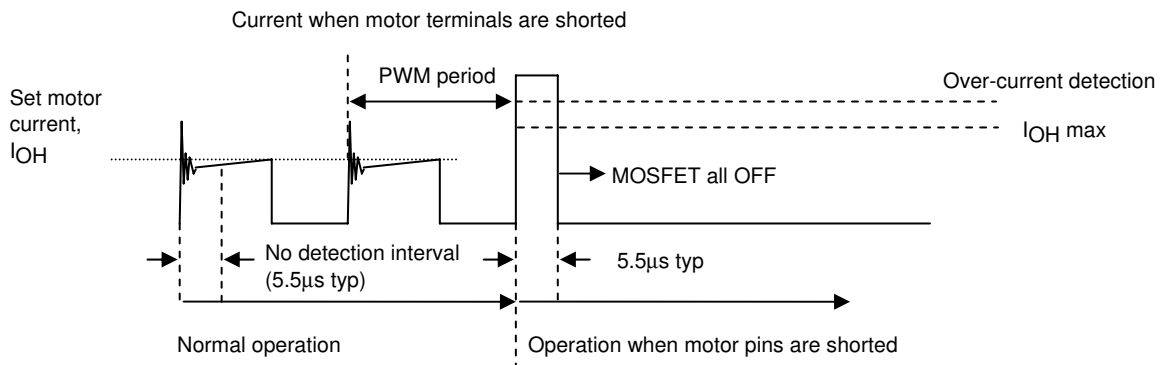

Overcurrent detection begins after an interval of no detection (a dead time of 5.5 μ s typ) during the initial ringing part during PWM operations. The no detection interval is a period of time where overcurrent is not detected even if the current exceeds I_{OH} .

[Overheat detection]

Rather than directly detecting the temperature of the semiconductor device, overheat detection detects the temperature of the aluminum substrate (144 $^{\circ}$ C typ).

Within the allowed operating range recommended in the specification manual, if a heat sink attached for the purpose of reducing the operating substrate temperature, T_c , comes loose, the semiconductor can operate without breaking.

However, we cannot guarantee operations without breaking in the case of operations other than those recommended, such as operations at a current exceeding I_{OH} max that occurs before overcurrent detection is activated.

3. Calculating STK672-740B-E HIC Internal Power Loss

The average internal power loss in each excitation mode of the STK672-740B-E can be calculated from the following formulas.

Each excitation mode

2-phase excitation mode

$$2PdAVex = (V_{sat} + V_{df}) \times (1 / (t_1 + t_2 + t_3)) \times I_{OH} \times t_2 + (1 / (t_1 + t_2 + t_3)) \times I_{OH} \times (V_{sat} \times t_1 + V_{df} \times t_3)$$

1-2 Phase excitation mode

$$1-2PdAVex = (V_{sat} + V_{df}) \times (1 / (t_1 + t_2 + t_3)) \times I_{OH} \times t_2 + (1 / (t_1 + t_2 + t_3)) \times I_{OH} \times (V_{sat} \times t_1 + V_{df} \times t_3)$$

Motor hold mode

$$HoldPdAVex = (V_{sat} + V_{df}) \times I_{OH}$$

V_{sat} : Combined voltage represented by the R_{on} voltage drop + shunt resistor

V_{df} : Combined voltage represented by the MOSFET body diode + shunt resistor

t_1 , t_2 , and t_3 represent the waveforms shown in the figure below.

t_1 : Time required for the winding current to reach the set current (I_{OH})

t_2 : Time in the constant current control (PWM) region

t_3 : Time from end of phase input signal until inverse current regeneration is complete

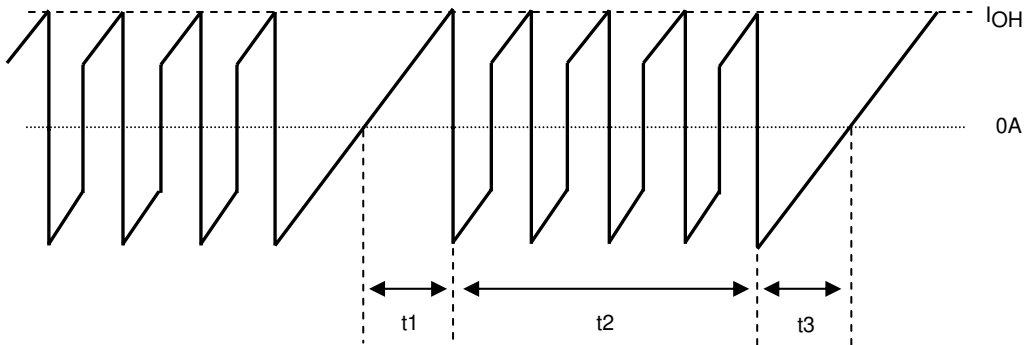

Motor COM Current Waveform Model

$$t_1 = (-L / (R + 0.20)) \ln (1 - ((R + 0.20) / V_{CC}) \times I_{OH})$$

$$t_3 = (-L / R) \ln ((V_{CC} + 0.20) / (I_{OH} \times R + V_{CC} + 0.20))$$

V_{CC} : Motor supply voltage (V)

L : Motor inductance (H)

R : Motor winding resistance (Ω)

I_{OH} : Motor set output current crest value (A)

For V_{sat} and V_{df} , be sure to substitute values from the graphs of V_{sat} vs. I_{OH} and V_{df} vs. I_{OH} while the set current value is I_{OH} .

Then, determine whether a heat sink is required by comparing with the graph of ΔT_c vs. P_d based on the average HIC power loss calculated.

When designing a heat sink, refer to the section "Thermal design" found on the next page. The average HIC power loss, P_dAV , described above does not have the avalanche's loss. To include the avalanche's loss, be sure to add Equation (2), "STK672-7** Allowable Avalanche Energy Value" to P_dAV above. When using this IC without a fin always check for temperature increases in the set, because the HIC substrate temperature, T_c , varies due to effects of convection around the HIC.

STK672-740B-E

STK672-740B-E Output saturation voltage, V_{sat} - Output current, I_{OH}

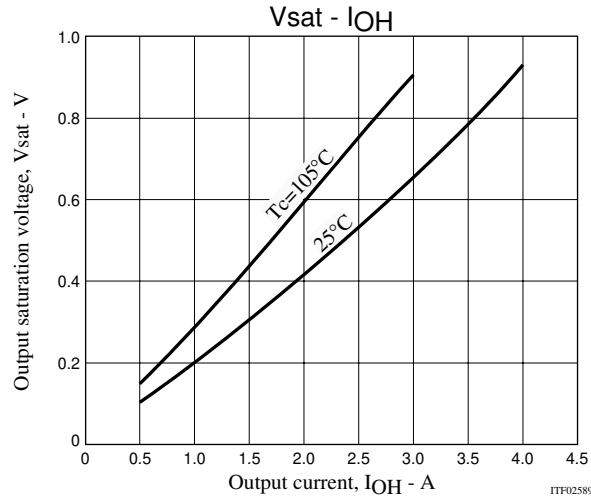

STK672-740B-E Forward voltage, V_{df} - Output current, I_{OH}

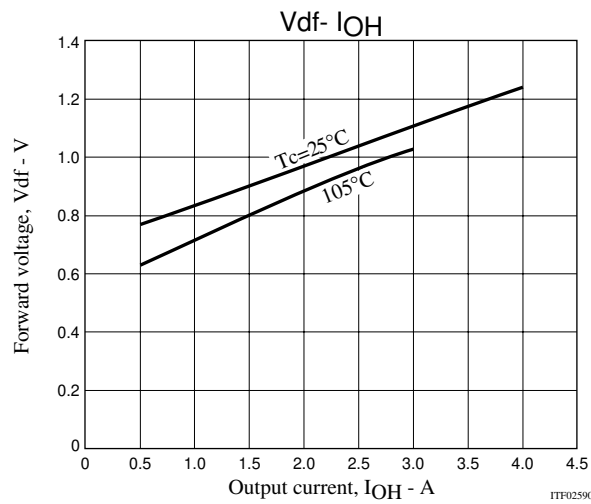

Substrate temperature rise, ΔT_c (no heat sink) - Internal average power dissipation, P_{dAV}

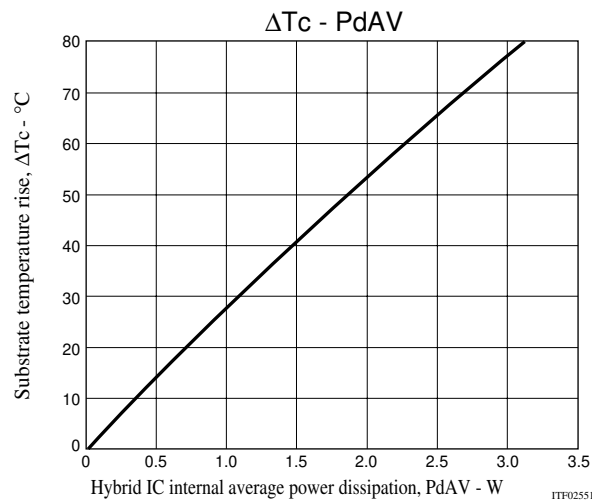

4. STK672-740B-E Allowable Avalanche Energy Value

(1) Allowable Range in Avalanche Mode

When driving a 2-phase stepping motor with constant current chopping using an STK672-7** Series hybrid IC, the waveforms shown in Figure 1 below result for the output current, I_D , and voltage, V_{DS} .

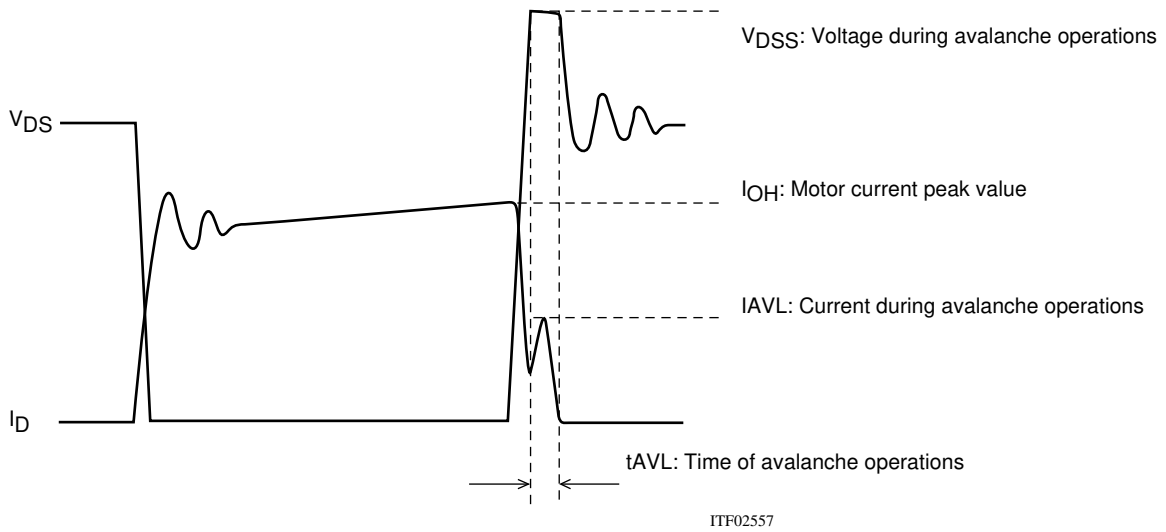

Figure 1 Output Current, I_D , and Voltage, V_{DS} , Waveforms 1 of the STK672-7** Series when Driving a 2-Phase Stepping Motor with Constant Current Chopping

When operations of the MOSFET built into STK672-7** Series ICs is turned off for constant current chopping, the I_D signal falls like the waveform shown in the figure above. At this time, the output voltage, V_{DS} , suddenly rises due to electromagnetic induction generated by the motor coil.

In the case of voltage that rises suddenly, voltage is restricted by the MOSFET V_{DSS} . Voltage restriction by V_{DSS} results in a MOSFET avalanche. During avalanche operations, I_D flows and the instantaneous energy at this time, E_{AVL1} , is represented by Equation (1).

$$E_{AVL1} = V_{DSS} \times I_{AVL} \times 0.5 \times t_{AVL} \text{ ----- (1)}$$

V_{DSS} : V units, I_{AVL} : A units, t_{AVL} : sec units

The coefficient 0.5 in Equation (1) is a constant required to convert the I_{AVL} triangle wave to a square wave.

During STK672-7** Series operations, the waveforms in the figure above repeat due to the constant current chopping operation. The allowable avalanche energy, E_{AVL} , is therefore represented by Equation (2) used to find the average power loss, P_{AVL} , during avalanche mode multiplied by the chopping frequency in Equation (1).

$$P_{AVL} = V_{DSS} \times I_{AVL} \times 0.5 \times t_{AVL} \times f_c \text{ ----- (2)}$$

f_c : Hz units (f_c is set to the PWM frequency of 50kHz.)

For V_{DSS} , I_{AVL} , and t_{AVL} , be sure to actually operate the STK672-7** Series and substitute values when operations are observed using an oscilloscope.

Ex. If $V_{DSS}=110V$, $I_{AVL}=1A$, $t_{AVL}=0.2\mu s$ when using a STK672-740B-E driver, the result is:

$$P_{AVL} = 110 \times 1 \times 0.5 \times 0.2 \times 10^{-6} \times 50 \times 10^3 = 0.55W$$

$V_{DSS}=110V$ is a value actually measured using an oscilloscope.

The allowable loss range for the allowable avalanche energy value, P_{AVL} , is shown in the graph in Figure 3. When examining the avalanche energy, be sure to actually drive a motor and observe the I_D , V_{DS} , and t_{AVL} waveforms during operation, and then check that the result of calculating Equation (2) falls within the allowable range for avalanche operations.

(2) I_D and V_{DS} Operating Waveforms in Non-avalanche Mode

Although the waveforms during avalanche mode are given in Figure 1, sometimes an avalanche does not result during actual operations.

Factors causing avalanche are listed below.

- Poor coupling of the motor's phase coils (electromagnetic coupling of A phase and AB phase, B phase and BB phase).
- Increase in the lead inductance of the harness caused by the circuit pattern of the P.C. board and motor.
- Increases in V_{DSS} , t_{AVL} , and I_{AVL} in Figure 1 due to an increase in the supply voltage from 24V to 36V.

If the factors above are negligible, the waveforms shown in Figure 1 become waveforms without avalanche as shown in Figure 2.

Under operations shown in Figure 2, avalanche does not occur and there is no need to consider the allowable loss range of $PAVL$ shown in Figure 3.

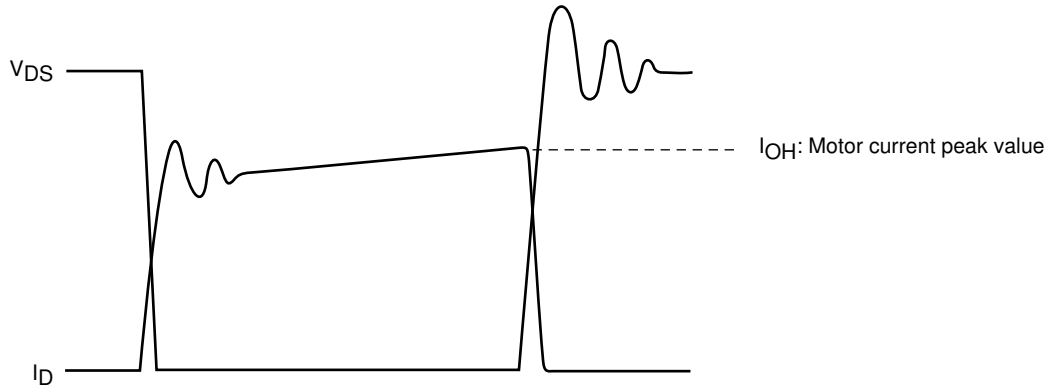

ITF02558

Figure 2 Output Current, I_D , and Voltage, V_{DS} , Waveforms 2 of the STK672-7** Series when Driving a 2-Phase Stepping Motor with Constant Current Chopping

Figure 3 Allowable Loss Range, $PAVL-I_{OH}$ During Avalanche Operations

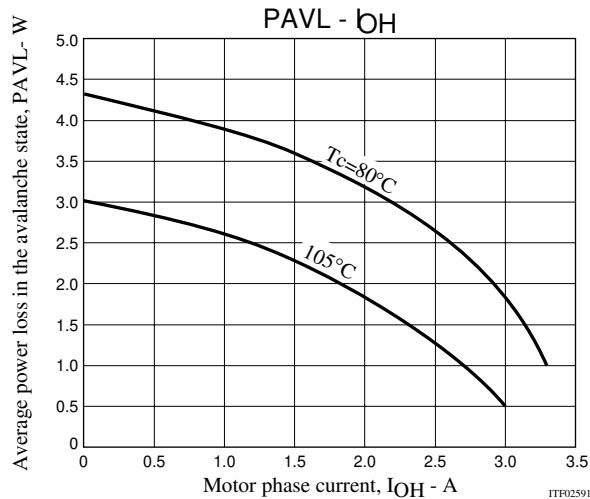

ITF02591

Note:

The operating conditions given above represent a loss when driving a 2-phase stepping motor with constant current chopping.

Because it is possible to apply 3W or more at $I_{OH}=0A$, be sure to avoid using the MOSFET body diode that is used to drive the motor as a zener diode.

5. Thermal design

[Operating range in which a heat sink is not used]

Use of a heat sink to lower the operating substrate temperature of the HIC (Hybrid IC) is effective in increasing the quality of the HIC.

The size of heat sink for the HIC varies depending on the magnitude of the average power loss, PdAV, within the HIC. The value of PdAV increases as the output current increases. To calculate PdAV, refer to “Calculating Internal HIC Loss for the STK672-740B-E”.

Calculate the internal HIC loss, PdAV, assuming repeat operation such as shown in Figure 1 below, since conduction during motor rotation and off time both exist during actual motor operations,

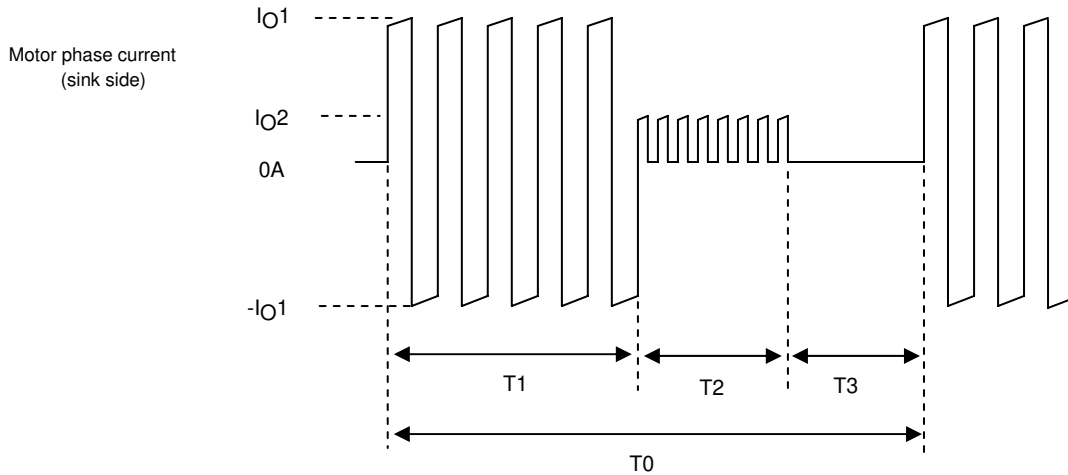

Figure 1 Motor Current Timing

T1: Motor rotation operation time

T2: Motor hold operation time

T3: Motor current off time

T2 may be reduced, depending on the application.

T0: Single repeated motor operating cycle

IO1 and IO2: Motor current peak values

Due to the structure of motor windings, the phase current is a positive and negative current with a pulse form.

Note that figure 1 presents the concepts here, and that the on/off duty of the actual signals will differ.

The hybrid IC internal average power dissipation PdAV can be calculated from the following formula.

$$PdAV = (T1 \times P1 + T2 \times P2 + T3 \times 0) \div T0 \text{ ----- (I)}$$

(Here, P1 is the PdAV for IO1 and P2 is the PdAV for IO2)

If the value calculated using Equation (I) is 1.5W or less, and the ambient temperature, Ta, is 60°C or less, there is no need to attach a heat sink. Refer to Figure 2 for operating substrate temperature data when no heat sink is used.

[Operating range in which a heat sink is used]

Although a heat sink is attached to lower Tc if PdAV increases, the resulting size can be found using the value of θc-a in Equation (II) below and the graph depicted in Figure 3.

$$\theta_{c-a} = (Tc \text{ max} - Ta) \div PdAV \text{ ----- (II)}$$

Tc max: Maximum operating substrate temperature =105°C

Ta: HIC ambient temperature

Although a heat sink can be designed based on equations (I) and (II) above, be sure to mount the HIC in a set and confirm that the substrate temperature, Tc, is 105°C or less.

The average HIC power loss, PdAV, described above represents the power loss when there is no avalanche operation. To add the loss during avalanche operations, be sure to add Equation (2), “Allowable STK672-7** Avalanche Energy Value”, to PdAV.

Figure 2 Substrate temperature rise, ΔT_c (no heat sink) - Internal average power dissipation, PdAV

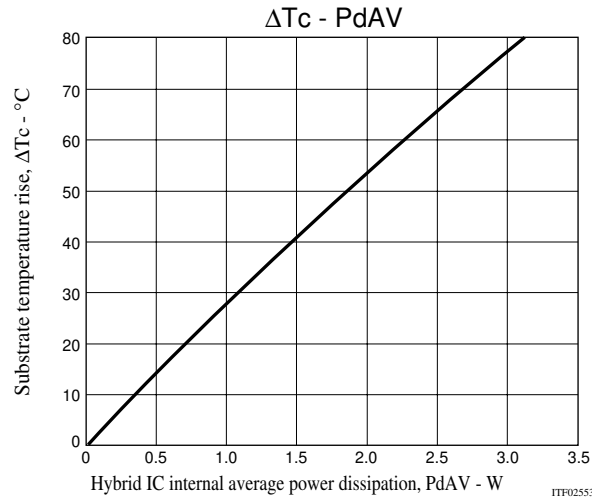
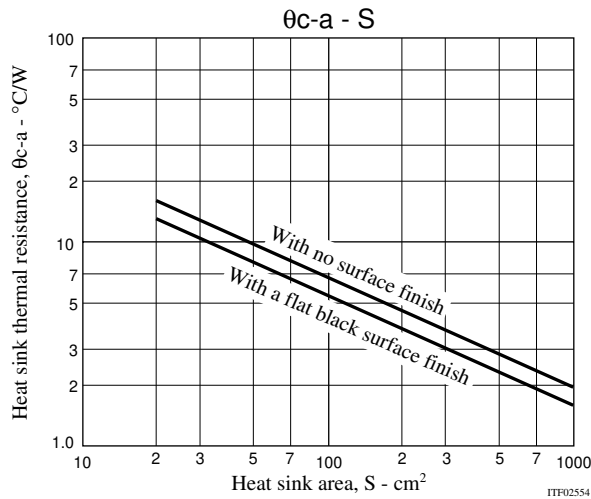

Figure 3 Heat sink area (Board thickness: 2mm) - θ_{c-a}



6. Mitigated Curve of Package Power Loss, PdPK, vs. Ambient Temperature, Ta

Package power loss, PdPK, refers to the average internal power loss, PdAV, allowable without a heat sink. The figure below represents the allowable power loss, PdPK, vs. fluctuations in the ambient temperature, Ta. Power loss of up to 3.1W is allowable at Ta=25°C, and of up to 1.75W at Ta=60°C.

Allowable power dissipation, PdPK(no heat sink) - Ambient temperature, Ta

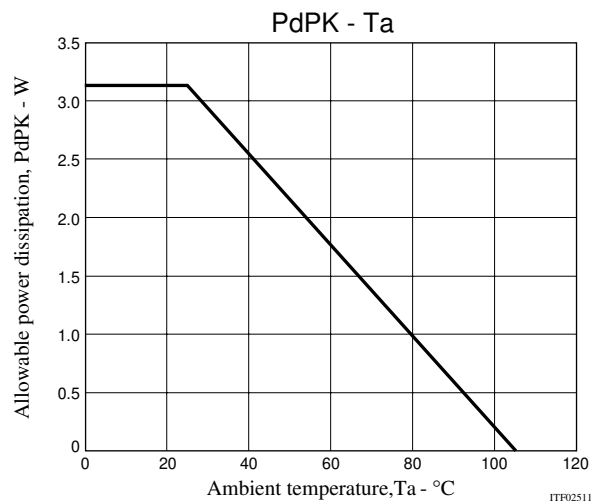

STK672-740B-E

7. Example of Stepping Motor Driver Output Current Path (1-2 phase excitation)

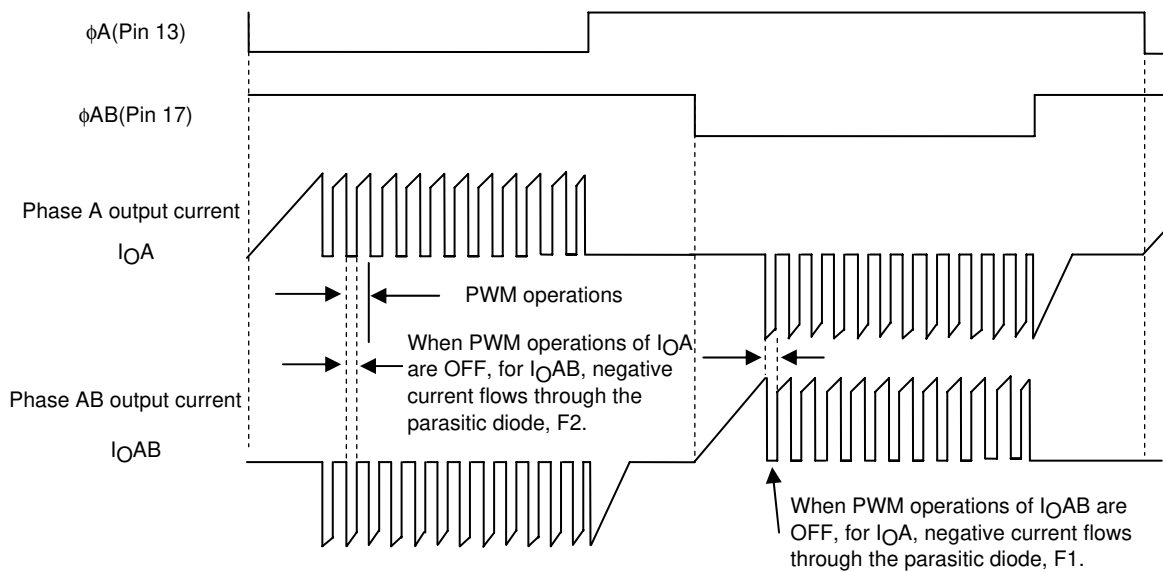
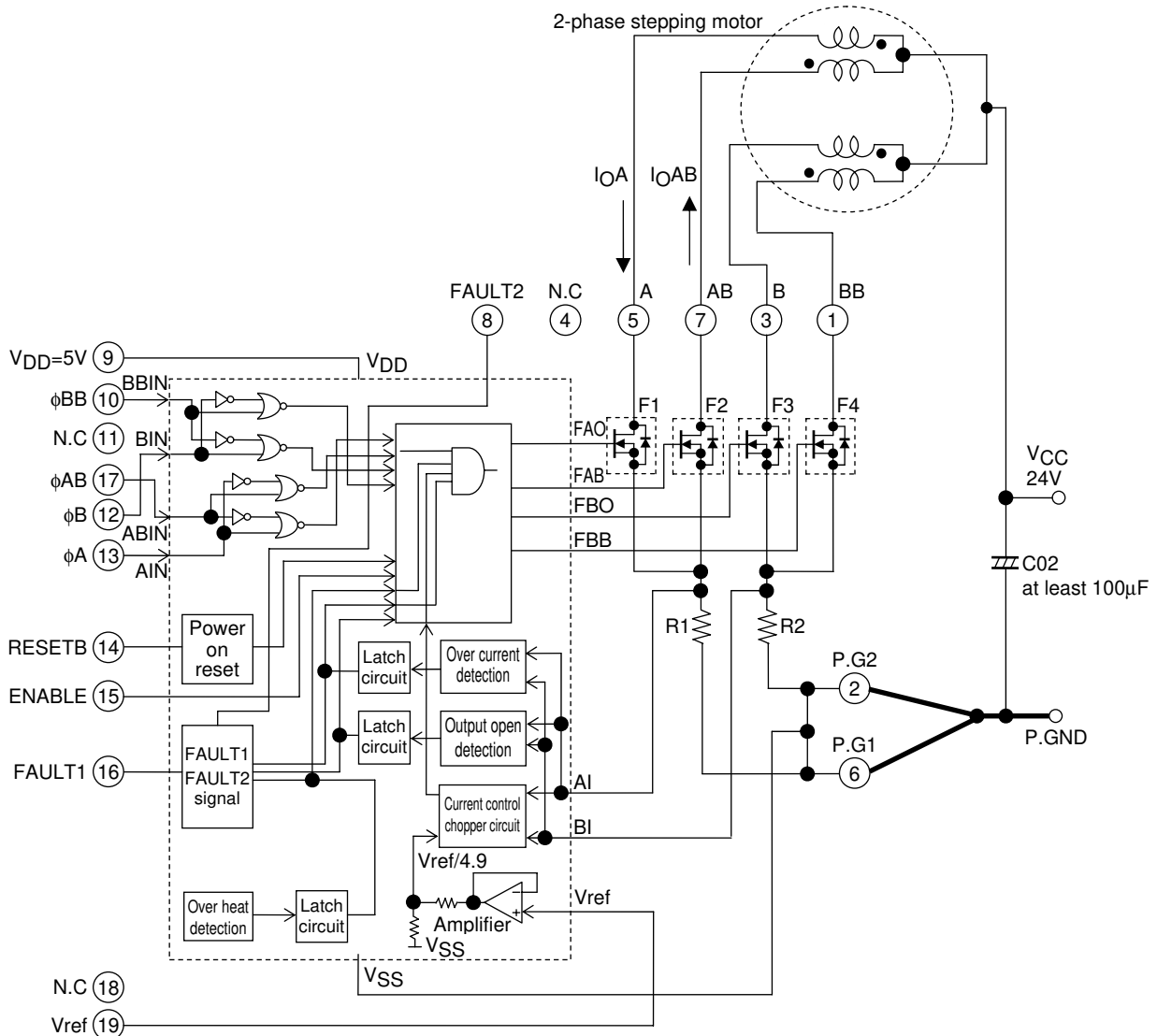

8. Other Notes on Use

In addition to the “Notes” indicated in the Sample Application Circuit, care should also be given to the following contents during use.

(1) Allowable operating range

Operation of this product assumes use within the allowable operating range. If a supply voltage or an input voltage outside the allowable operating range is applied, an overvoltage may damage the internal control IC or the MOSFET.

If a voltage application mode that exceeds the allowable operating range is anticipated, connect a fuse or take other measures to cut off power supply to the product.

(2) Input pins

If the input pins are connected directly to the PC board connectors, electrostatic discharge or other overvoltage outside the specified range may be applied from the connectors and may damage the product. Current generated by this overvoltage can be suppressed to effectively prevent damage by inserting 100Ω to 1kΩ resistors in lines connected to the input pins.

Take measures such as inserting resistors in lines connected to the input pins.

(3) Power connectors

If the motor power supply V_{CC} is applied by mistake without connecting the GND part of the power connector when the product is operated, such as for test purposes, an overcurrent flows through the V_{CC} decoupling capacitor, C1, to the parasitic diode between the V_{DD} of the internal control IC and GND, and may damage the power supply pin block of the internal control IC.

To prevent destruction in this case, connect a 10Ω resistor to the V_{DD} pin, or insert a diode between the V_{CC} decoupling capacitor C1 GND and the V_{DD} pin.

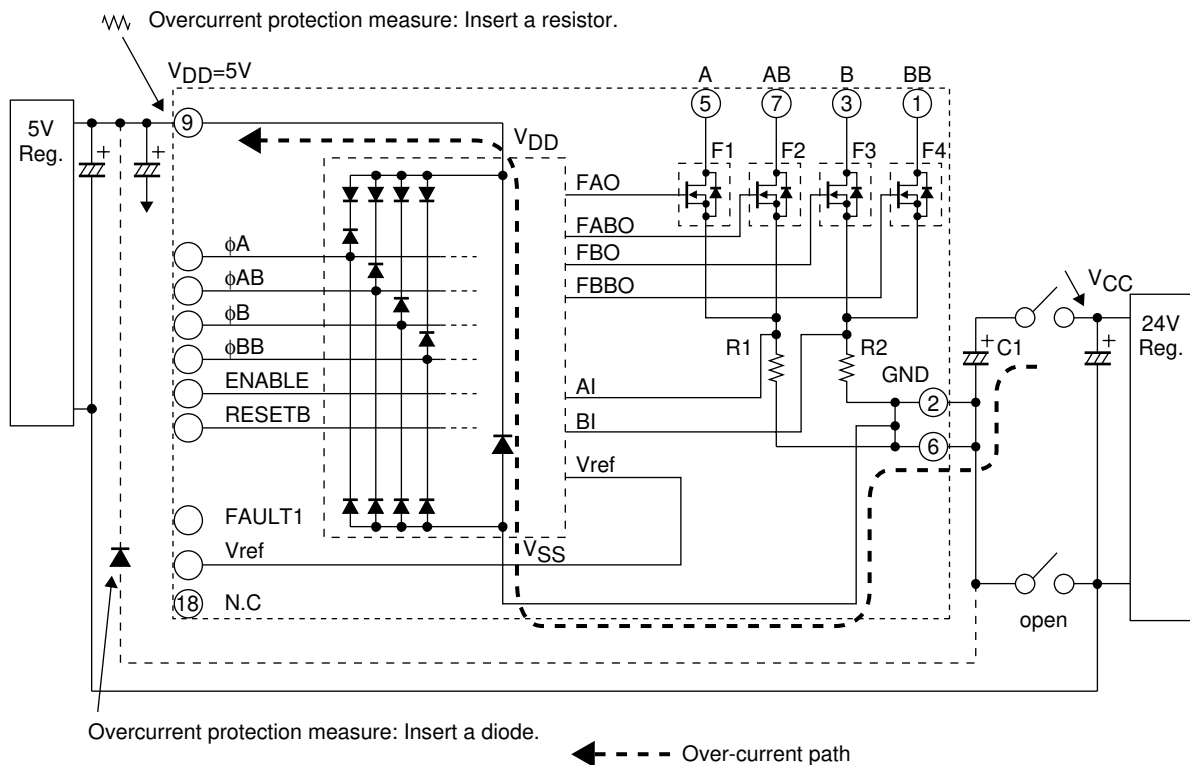

(4) Input Signal Lines

- 1) Do not use an IC socket to mount the driver, and instead solder the driver directly to the PC board to minimize fluctuations in the GND potential due to the influence of the resistance component and inductance component of the GND pattern wiring.
- 2) To reduce noise caused by electromagnetic induction to small signal lines, do not design small signal lines (sensor signal lines, and 5V or 3.3V power supply signal lines) that run parallel in close proximity to the motor output line A (Pin 5), AB (Pin 7), B (Pin 3), or BB (Pin 1) phases.
- 3) Pin 4, 11 and Pin 18 of this product are N.C pins. Do not connect any wiring to these pins.

(5) When mounting multiple drivers on a single PC board

When mounting multiple drivers on a single PC board, the GND design should mount a V_{CC} decoupling capacitor, C1, for each driver to stabilize the GND potential of the other drivers. The key wiring points are as follows.

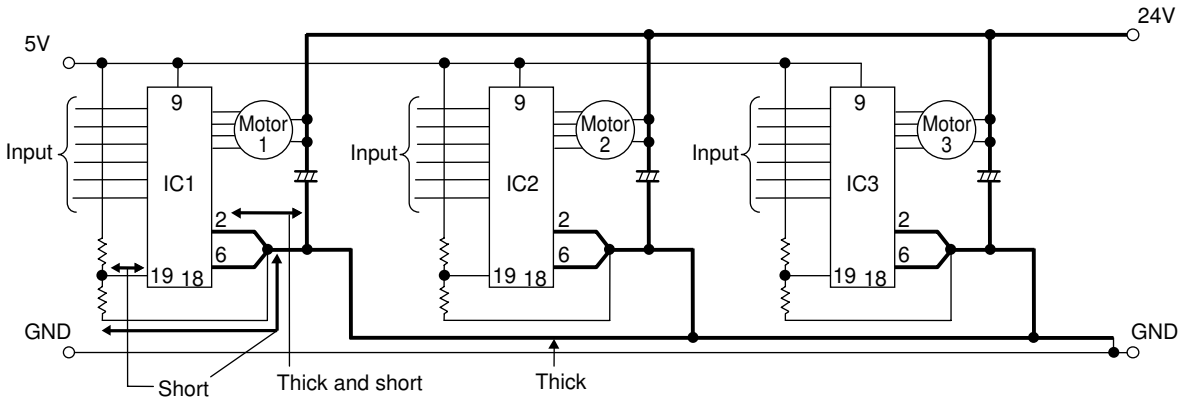

(6) V_{CC} operating limit

When the output (for example F1) of a 2-phase stepping motor driver is turned OFF, the AB phase back electromotive force e_{ab} produced by current flowing to the paired F2 parasitic diode is induced in the F1 side, causing the output voltage V_{FB} to become twice or more the V_{CC} voltage. This is expressed by the following formula.

$$V_{FB} = V_{CC} + e_{ab}$$

$$= V_{CC} + V_{CC} + I_{OH} \times R_M + V_{df} (1.5 V)$$

V_{CC} : Motor supply voltage, I_{OH} : Motor current set by V_{ref}

V_{df} : Voltage drop due to F2 parasitic diode and current detection resistor R1, R_M : Motor winding resistance value

Using the above formula, make sure that V_{FB} is always less than the MOSFET withstand voltage of 100V. This is because there is a possibility that operating limit of V_{CC} falls below the allowable operating range of 46V, due to the R_M and I_{OH} specifications.

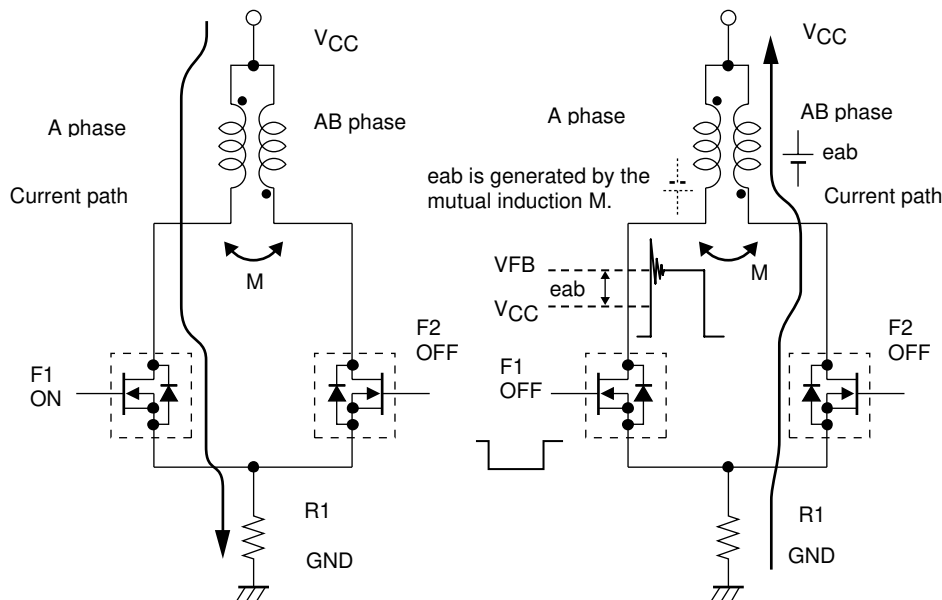

The oscillating voltage in excess of V_{FB} is caused by LCRM (inductance, capacitor, resistor, mutual inductance) oscillation that includes micro capacitors C, not present in the circuit. Since M is affected by the motor characteristics, there is some difference in oscillating voltage according to the motor specifications. In addition, constant voltage drive without constant current drive enables motor rotation at $V_{CC} > 0V$.

- SANYO Semiconductor Co.,Ltd. assumes no responsibility for equipment failures that result from using products at values that exceed, even momentarily, rated values (such as maximum ratings, operating condition ranges, or other parameters) listed in products specifications of any and all SANYO Semiconductor Co.,Ltd. products described or contained herein.
- SANYO Semiconductor Co.,Ltd. strives to supply high-quality high-reliability products, however, any and all semiconductor products fail or malfunction with some probability. It is possible that these probabilistic failures or malfunction could give rise to accidents or events that could endanger human lives, trouble that could give rise to smoke or fire, or accidents that could cause damage to other property. When designing equipment, adopt safety measures so that these kinds of accidents or events cannot occur. Such measures include but are not limited to protective circuits and error prevention circuits for safe design, redundant design, and structural design.
- In the event that any or all SANYO Semiconductor Co.,Ltd. products described or contained herein are controlled under any of applicable local export control laws and regulations, such products may require the export license from the authorities concerned in accordance with the above law.
- No part of this publication may be reproduced or transmitted in any form or by any means, electronic or mechanical, including photocopying and recording, or any information storage or retrieval system, or otherwise, without the prior written consent of SANYO Semiconductor Co.,Ltd.
- Any and all information described or contained herein are subject to change without notice due to product/technology improvement, etc. When designing equipment, refer to the "Delivery Specification" for the SANYO Semiconductor Co.,Ltd. product that you intend to use.
- Information (including circuit diagrams and circuit parameters) herein is for example only; it is not guaranteed for volume production.
- Upon using the technical information or products described herein, neither warranty nor license shall be granted with regard to intellectual property rights or any other rights of SANYO Semiconductor Co.,Ltd. or any third party. SANYO Semiconductor Co.,Ltd. shall not be liable for any claim or suits with regard to a third party's intellectual property rights which has resulted from the use of the technical information and products mentioned above.

This catalog provides information as of July, 2011. Specifications and information herein are subject to change without notice.