

PART NO. 92311-0001  
 DWG. NO. SDA-92311-0001

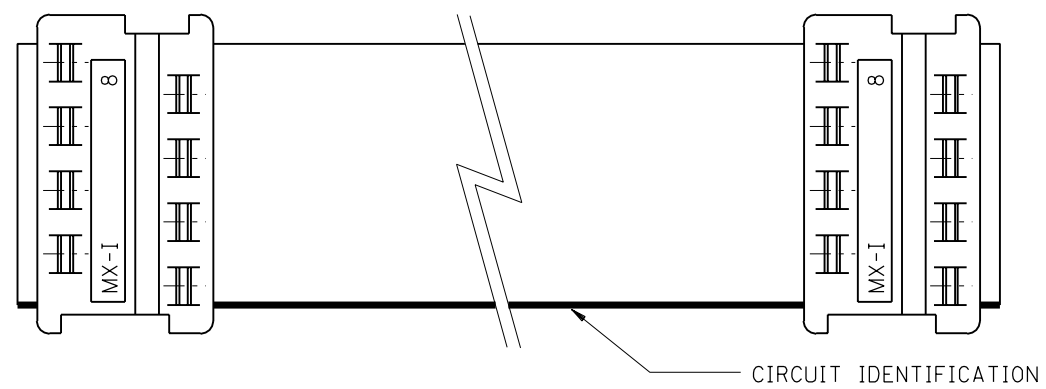
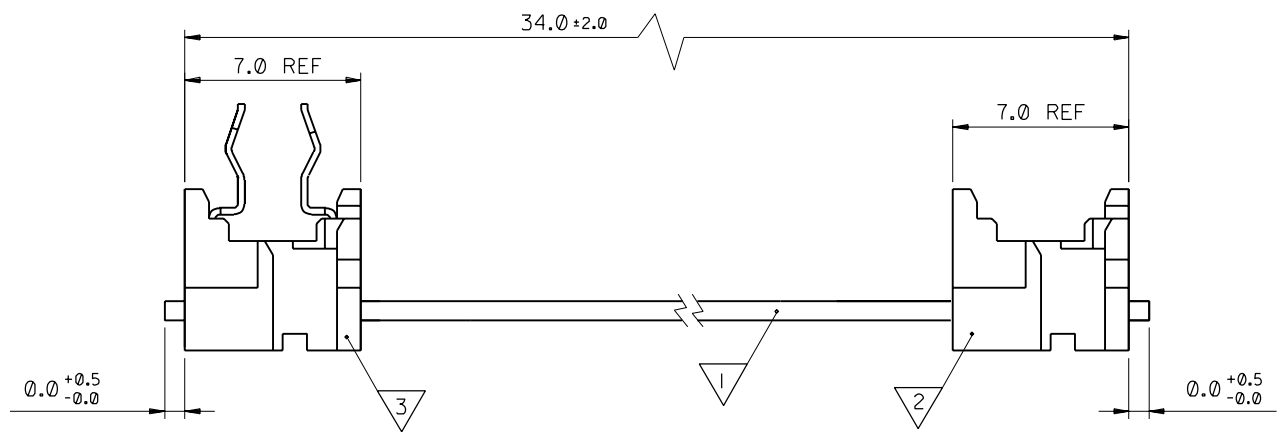

ITEM	COMPONENT	DESCRIPTION	QUANTITY	NOTE
▽	99026-0027	8 CKT 28 AWG STRANDED TINNED RIBBON CABLE	1	1, 4, 5
▽2	90327-0308	PICOFLEX FEMALE IDT CONNECTOR	1	1, 2, 5
▽3	90584-1308	PICOFLEX BOARD-IN IDT CONNECTOR	1	1, 3, 5

NOTES:

- SEE PRODUCT SPECIFICATIONS PS-99020-0011.
- SEE TERMINATION SPECIFICATION ES-99033-0001.
- SEE TERMINATION SPECIFICATION ES-99033-0002.
- SEE CABLE SPECIFICATION ES-99027-0006.
- HARNESSES TO BE 100% ELECTRICALLY TESTED.

THIRD ANGLE PROJECTION REVISE ONLY ON CAD SYSTEM SH. REV.

ORIGINAL ISSUE ECN E71040 97-06-18 AMC	REVISIONS	DIMENSIONS SHOWN ( METRIC ) INCH UNLESS OTHERWISE SPECIFIED TOLERANCES: ANGULAR ±2°	DRWG BY <b>AMC</b>	CAD/CAM FILENAME S92311X1 DGN	THIS DRAWING CONTAINS INFORMATION THAT IS PROPRIETARY TO MOLEX INC. & SHOULD NOT BE USED WITHOUT WRITTEN PERMISSION	
		INCH ( METRIC )	CHK'D BY	TITLE <b>PICOFLEX HARNESS</b>		
		3 PLACE ± 2 PLACE ± 1 PLACE ±	APP'D BY	SHEET NO. DATE 10F1 97/04/03		
		DRAFT WHERE APPLICABLE MUST REMAIN WITHIN DIMENSIONS	SCALE <b>5:1</b>	PART NO. <b>92311-0001</b>		DWG NO. <b>SDA-92311-0001</b>
		DESIGN DIMENSION <input checked="" type="checkbox"/> (MM) (PRIMARY) <input type="checkbox"/> IN.		SIZE <b>B</b>		
		EQUIVALENT DIMENSION <input type="checkbox"/> (MM) (SECONDARY) <input type="checkbox"/> IN.				