

PART NUMBER	REVISION	DESCRIPTION	FEED TYPE
2266485-1	H	FINE CRIMP HEIGHT ADJUST	MECHANICAL
2266485-2	H	FINE CRIMP HEIGHT ADJUST	PNEUMATIC
7-2266485-1	H	MECHANICAL AND CRIMP TOOLING KIT	MECHANICAL
7-2266485-2	H	PNEUMATIC AND CRIMP TOOLING KIT	PNEUMATIC
7-2266485-7	D	CRIMP TOOLING KIT	-

ATLANTIC VERSION TERMINATOR INTERFACE ADAPTER

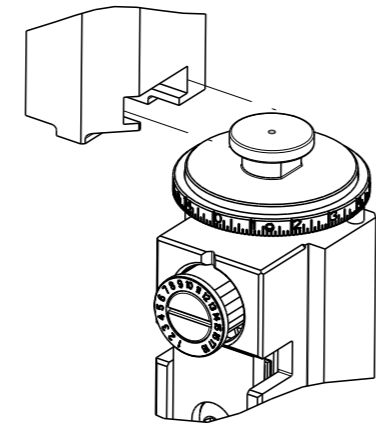

APPLICATOR DATA		
CRIMP	SIZE	TYPE
WIRE	3.00 mm [.118]	F
INSUL	3.05 mm [.120]	F

APPLICATOR INSTRUCTIONS 408-35042

TERMINAL DATA: YAZAKI TERMINAL YAZAKI CRIMP SPECIFICATION	
TERMINAL NAME: 2.3 II (090 II) TERMINAL FEMALE	
WIRE STRIP LENGTH 5.00-5.50 mm [.197-.217 IN]	INSULATION DIAMETER RANGE Ø2.90-3.10 mm [.114-.122 IN]
TERMINAL APPLICATION SPECIFICATION YAZAKI 7116-4022 Rev -	
TERMINALS APPLIED	
TE TERMINAL 1949886-1	YAZAKI TERMINAL 7116-4022
TE TERMINAL 1949886-2	YAZAKI TERMINAL 7B16-4022

WIRE SIZE	CRIMP HEIGHT mm [INCH]	CRIMP HEIGHT REFERENCE SETTING
2.00mm2	1.40+/-0.05 [.055+/- .002]	8.4



- 1. RECOMMENDED SPARE PARTS
- 2. REFER TO SUPPLIED INSTRUCTION SHEET FOR CLEANING, LUBRICATION AND STORAGE OF APPLICATOR.
- 3. APPLY PART NUMBER 2-23419-6 LOCTITE TO THREADS OF ITEM 242.
- 4. CRIMP HEIGHT REFERENCE SETTING WAS THE SETTING USED WHEN THE APPLICATOR WAS QUALIFIED AT THE FACTORY. ADJUSTMENT MAY BE NECESSARY WHEN RUNNING APPLICATOR IN THE FIELD.
- 5. TERMINAL LUBRICANT IS RECOMMENDED.
- 6. UNLESS SPECIFIED OTHERWISE TORQUE VALUES SHALL BE USED PER DOCUMENT, 101-35000.

**\*WARNING**  
ON INSTALLATION, SET WIRE DISC TO CRIMP HEIGHT REFERENCE SETTING FOR LARGEST WIRE SIZE. CRIMP HEIGHT REFERENCE SETTINGS GREATER THAN THE VALUE SHOWN MAY CAUSE DAMAGE TO THE CRIMP TOOLING, REFER TO THE INSTRUCTION SHEET FOR PROPER SETUP AND ADJUSTMENTS.

LOC	DIST	REVISIONS			
A	66	REV	DATE	BY	CHK
		E	05JUN2017	KH	LZ
		F	08AUG2017	TB	JDG
		G	09MAY2018	VLA	JDG
		H	10MAR2021	JWC	TE

-	1	-	1	-	2119641-1	FEED CAM, AIR FEED	248
-	1	1	1	1	2119082-3	CAM, SNAIL, INSULATION ADJUSTMENT	244
-	1	1	1	1	2079764-1	WASHER, WAVE SPRING, CREST-TO-CREST	243
3	-	1	1	1	2119083-1	RETAINER, INSULATION DIAL	242
-	1	1	1	1	7-18023-7	SCR, SKT HD CAP M3 X 4.0	241
-	-	1	-	-	2119580-1	MECHANICAL FEED ASSEMBLY	239
-	1	-	1	-	2844940-1	AIR FEED MODULE	238
5	-	REF	REF	REF	994970-2	COUNTER, MAGNETIC	164
-	1	1	1	1	2119955-1	ASSY, LUBRICATOR, SIDE FEED	113
-	1	1	1	1	2844908-1	SCREW, LOCKING	99
-	1	1	1	1	2844907-1	POST, LOCKING	98
-	1	1	1	1	455888-4	SPACER, CRIMPER	82
-	1	1	1	1	22278-8	SPRING, COMPRESSION	77
-	1	1	1	1	854769-4	HOLDER, INS	74
-	1	1	1	1	1803607-3	DOCUMENTATION PACKAGE	71
-	1	1	1	1	2119740-1	TAG, IDENTIFICATION	67
-	2	2	2	2	2168078-1	SCREW, DRIVE, RH, RoHS, 2 x .188	66
-	1	1	1	1	2168083-2	SCR, SKT HD CAP, RoHS, M4 X 8.0	60
-	1	1	1	1	5-18022-5	SCR, HEX HD CAP, M4 X 6.0	59
-	1	1	1	1	21028-2	PIN, SLOTTED SPRING .062 X .250	58
-	1	1	1	1	1338685-1	PAWL, FEED	56
-	4	4	4	4	2168083-3	SCR, SKT HD CAP, RoHS, M4 X 12.0	54
-	2	2	2	2	1-2168083-0	SCR, SKT HD CAP, RoHS, M4 X 10	53
-	1	1	1	1	1803382-6	HOLD DOWN, SPRING LOADED	50
-	1	2	1	2	18023-9	SCR, SKT HD CAP M4 X 6.0	49
-	-	1	-	-	2119652-1	FEED CAM, PRE FEED	48
-	-	1	-	-	2119653-1	FEED CAM, POST FEED	47
-	1	1	1	1	1803583-9	APPLICATOR BASIC ASSEMBLY, SF	46
-	1	1	1	1	1803515-1	RAM ASSEMBLY, SF ATLANTIC	44
-	1	1	1	1	1803602-1	SCR, BHSC, RoHS (M8 X 25)	41
-	1	1	1	1	1752356-1	SUPPORT, TERMINAL	34
-	2	2	2	2	2079383-5	SCR, BHSC, RoHS (M4 X 20)	33
-	2	2	2	2	2-2844962-8	SPACER, CYLINDRICAL, STRIP GUIDE	30
-	1	1	1	1	2844992-1	ASSEMBLY, STRIP GUIDE	29
-	1	1	1	1	1-455888-5	SPACER, CRIMPER	28
-	1	1	1	1	1320928-2	STRIP GUIDE	24
-	1	1	1	1	2168083-2	SCR, SKT HD CAP, RoHS, M4 X 8.0	21
-	2	2	2	2	1-18028-2	WASHER, FLAT, REG M4	20
-	1	1	1	1	2119533-1	STRIPPER, SIDE FEED	19
1	-	1	1	1	2119806-1	INSERT, SHEAR	13
-	1	1	1	1	3-22280-3	SPRING, COMPRESSION	12
-	1	1	1	1	1-356885-4	STOP, SHEAR	11
1	-	1	1	1	2119805-1	SHEAR HOLDER, FRONT	10
1	-	1	1	1	1803095-1	FLOATING SHEAR, FRONT	9
1	2	2	1	1	7-1633932-5	ANVIL, COMBINATION	8
-	-	-	-	-	-	-	7
-	-	-	-	-	-	-	6
-	1	1	1	1	2119780-7	DEPRESSOR, SHEAR	5
-	1	1	1	1	5-238011-2	BLOCK, CRIMPER SPACER	4
1	2	2	1	1	1803242-1	CRIMPER, INSULATION F PREMIUM	3
-	-	-	-	-	-	-	2
1	2	2	1	1	6-1333281-5	CRIMPER, WIRE PREMIUM	1
-77	-72	-71	-2	-1	PART NO	DESCRIPTION	ITEM NO

ATLANTIC VERSION  
Shown on sheets 1 of 4 & 2 of 4  
(Pacific version shown on sheets 3 of 4 & 4 of 4)

DIMENSIONS:		TOLERANCES UNLESS OTHERWISE SPECIFIED:		OWN J. HOU 29AUGUST2014		TE Connectivity Harrisburg, PA 17105-3608	
mm	0 PLC ±	1 PLC ±	2 PLC ±	3 PLC ±	4 PLC ±	NAME Ocean Side Feed Applicator	
MATERIAL		FINISH		APVD U. GUO 29AUGUST2014		SIZE CAGE CODE DRAWING NO RESTRICTED TO	
				PRODUCT SPEC		A1 00779 C=2266485	
				APPLICATION SPEC		SCALE 1:2 SHEET 1 OF 4 REV H	
				WEIGHT		Customer Accessible Production Drawing	

LOC	DIST	REVISIONS			
A	66	REV	DATE	OWN	APVD
-	-	SEE SHEET 1	-	-	-

# FEED TYPE MECHANICAL

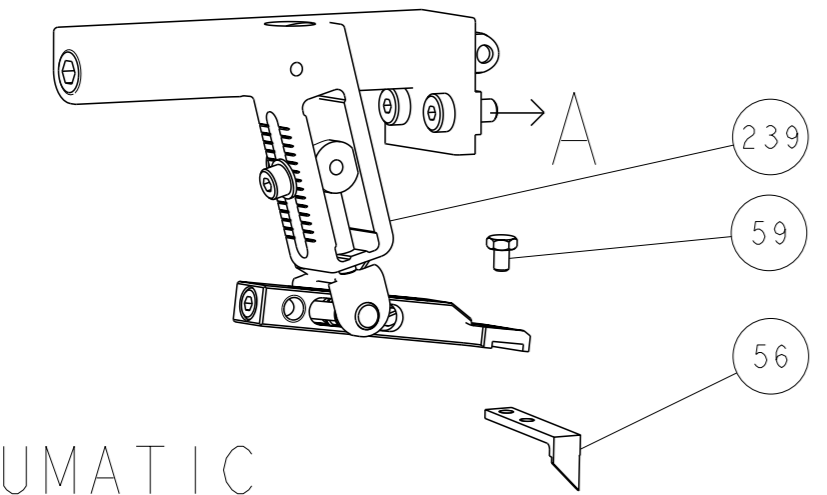

## PNEUMATIC

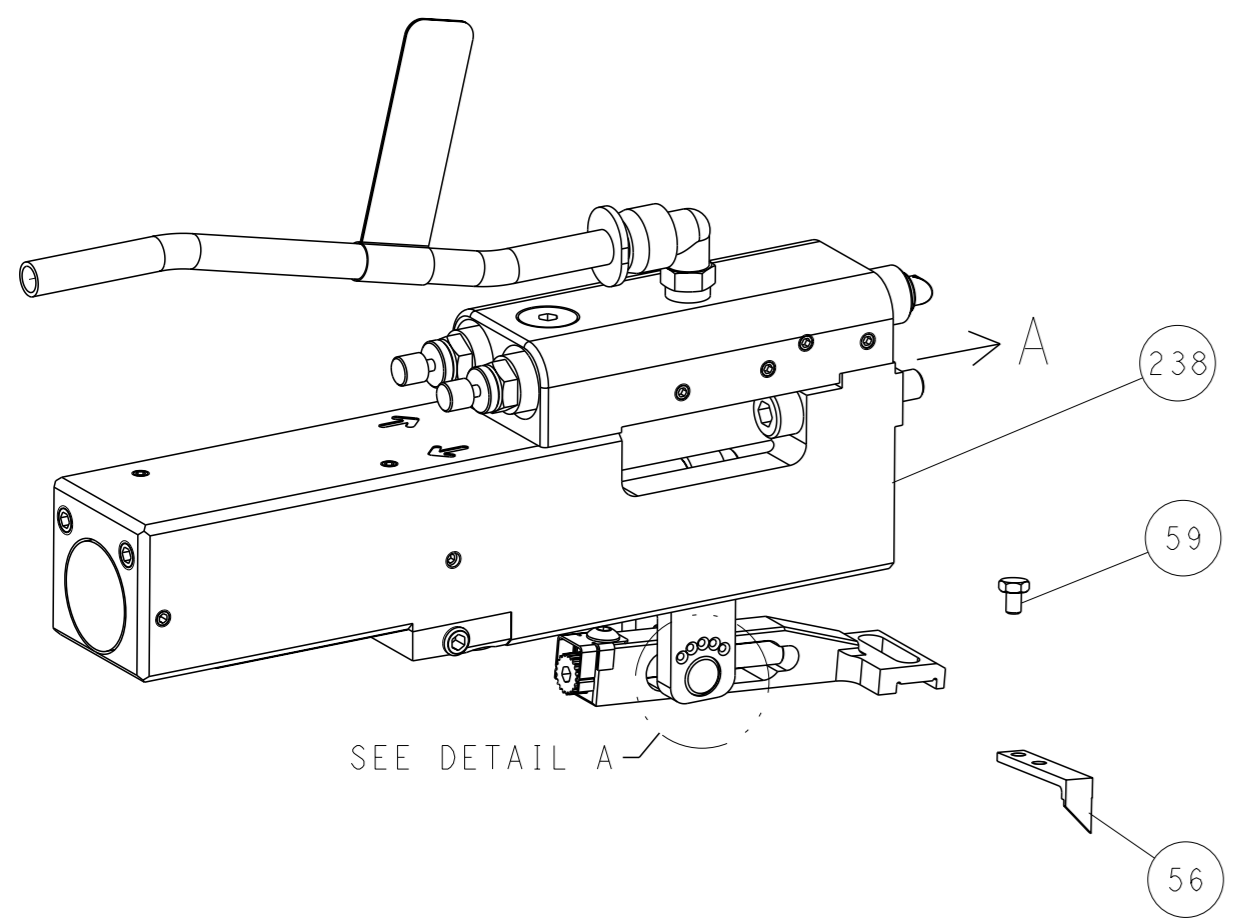

## FEED SPRING SETTING POSITION (SHOWN FROM REAR SIDE)

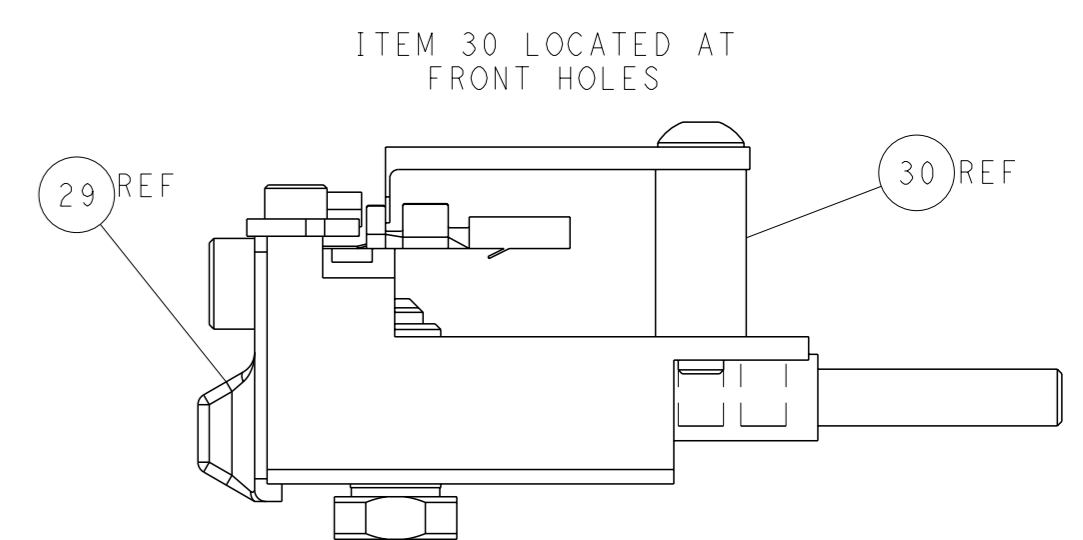
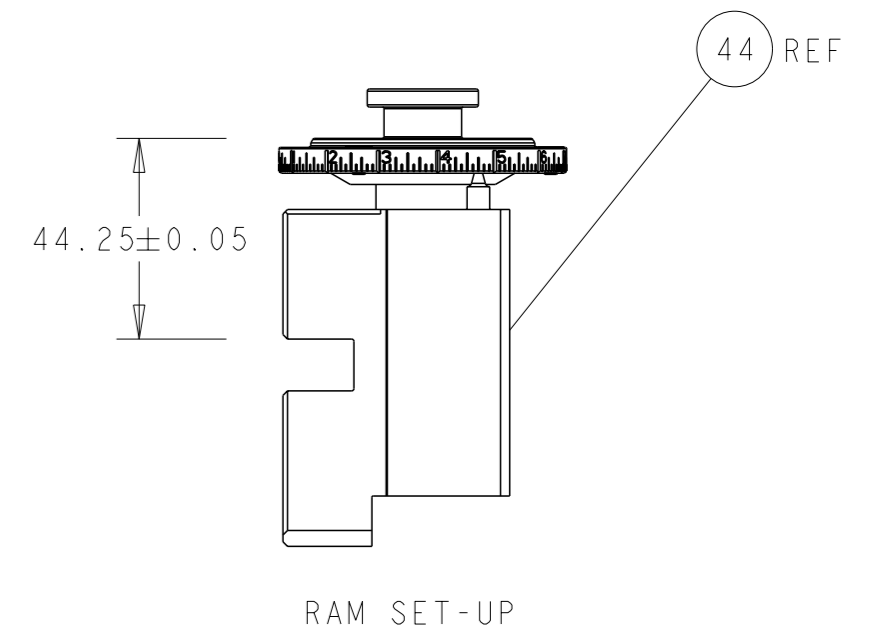
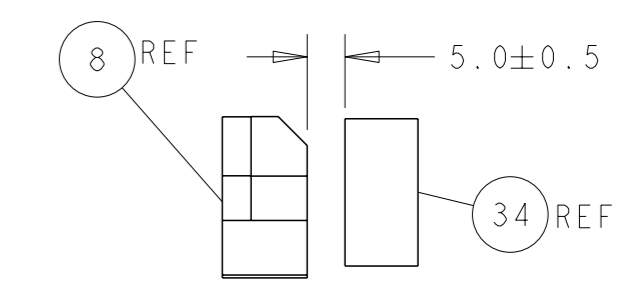
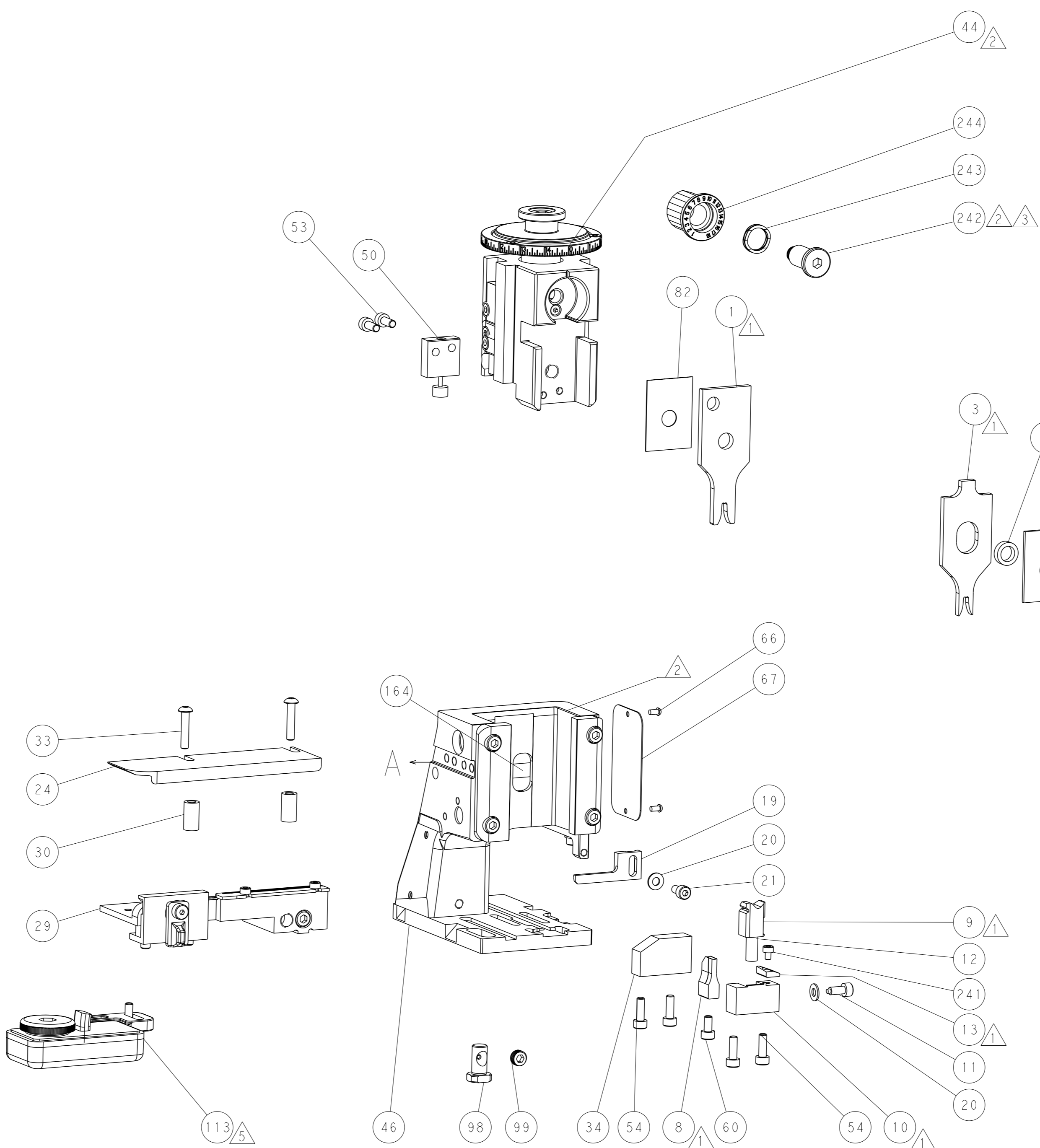
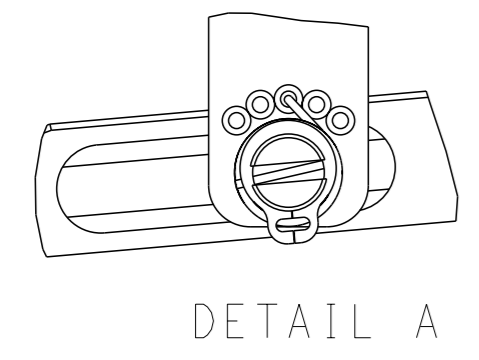

# CAM POSITIONS

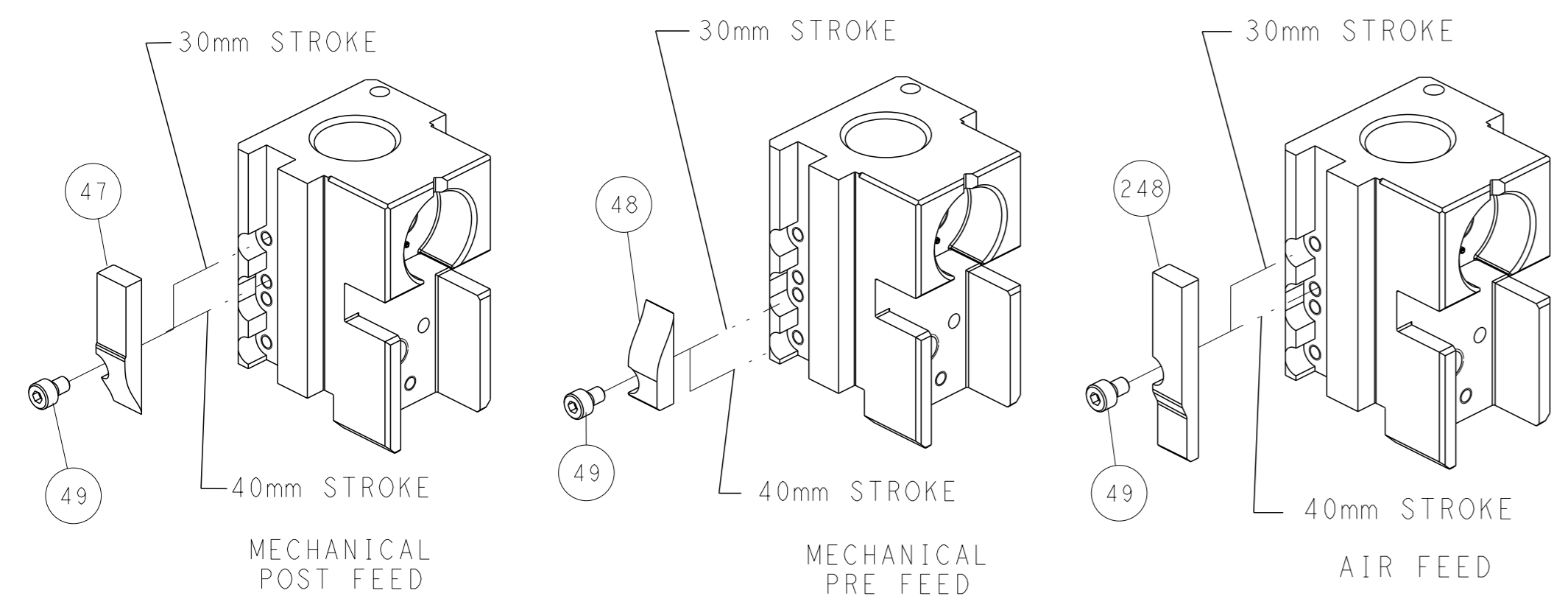

**ATLANTIC VERSION**  
 Shown on sheets 1 of 4 & 2 of 4  
 (Pacific version shown on sheets 3 of 4 & 4 of 4)

<small>THIS DRAWING IS A CONTROLLED DOCUMENT FOR TYCO ELECTRONICS CORPORATION. IT IS SUBJECT TO CHANGE AND THE USER MUST CONSULT THE DRAWING REVISIONS SHOULD BE CONTACTED FOR THE LATEST REVISION.</small>		OWN: J. HOW 29AUGUST2014 CHK: Y. YIN 29AUGUST2014 APVD: H. GUO 29AUGUST2014	TE Connectivity Harrisburg, PA 17105-3608
DIMENSIONS: mm TOLERANCES UNLESS OTHERWISE SPECIFIED: 0 PLC ± 1 PLC ± 2 PLC ± 3 PLC ± 4 PLC ± ANGLES FINISH ±		NAME: Ocean Side Feed Applicator SIZE: A1 CAGE CODE: 00779 DRAWING NO: C=2266485	RESTRICTED TO: - SCALE: 1:2 SHEET: 2 of 4 REV: H
MATERIAL: - FINISH: -		WEIGHT: - Customer Accessible Production Drawing	SHEETS 3 & 4 ARE NOT REQUIRED FOR ATLANTIC VERSION

THIS DRAWING IS UNPUBLISHED.	RELEASED FOR PUBLICATION		
© COPYRIGHT 20 BY TYCO ELECTRONICS CORPORATION. ALL RIGHTS RESERVED.	20		
PART NUMBER	REVISION	DESCRIPTION	FEED TYPE
2-2266485-1	H	FINE CRIMP HEIGHT ADJUST	MECHANICAL
2-2266485-2	H	FINE CRIMP HEIGHT ADJUST	PNEUMATIC
7-2266485-7	D	CRIMP TOOLING KIT	-

PACIFIC VERSION TERMINATOR  
INTERFACE ADAPTER

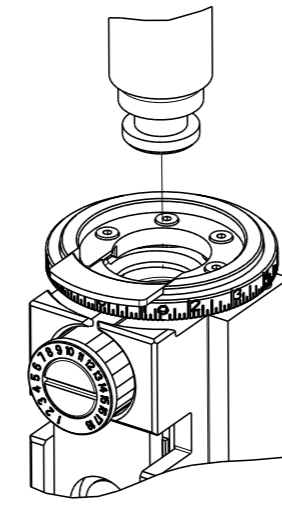

APPLICATOR DATA		
CRIMP	SIZE	TYPE
WIRE	3.00 mm (.118)	F
INSUL	3.05 mm (.120)	F
APPLICATOR INSTRUCTIONS 408-35042		

TERMINAL DATA: YAZAKI TERMINAL YAZAKI CRIMP SPECIFICATION	
TERMINAL NAME: 2.3 II (090 II) TERMINAL FEMALE	
WIRE STRIP LENGTH 5.00-5.50 mm (.197-.217 IN)	INSULATION DIAMETER RANGE Ø2.90-3.10 mm (.114-.122 IN)
TERMINAL APPLICATION SPECIFICATION YAZAKI 7116-4022 Rev -	
TERMINALS APPLIED	
TE TERMINAL	YAZAKI TERMINAL
1949886-1	7116-4022
TE TERMINAL	YAZAKI TERMINAL
1949886-2	7B16-4022

WIRE SIZE	CRIMP HEIGHT mm [INCH]	CRIMP HEIGHT REFERENCE SETTING
2.00mm2	1.40 +/- 0.05 [.055 +/- .002]	8.4



- 1 RECOMMENDED SPARE PARTS
- 2 REFER TO SUPPLIED INSTRUCTION SHEET FOR CLEANING, LUBRICATION AND STORAGE OF APPLICATOR.
- 3 APPLY PART NUMBER 2-23419-6 LOCTITE TO THREADS OF ITEM 242.
- 4 CRIMP HEIGHT REFERENCE SETTING WAS THE SETTING USED WHEN THE APPLICATOR WAS QUALIFIED AT THE FACTORY. ADJUSTMENT MAY BE NECESSARY WHEN RUNNING APPLICATOR IN THE FIELD.
- 5 TERMINAL LUBRICANT IS RECOMMENDED.
- 6. UNLESS SPECIFIED OTHERWISE TORQUE VALUES SHALL BE USED PER DOCUMENT, 101-35000.

**\*WARNING**  
ON INSTALLATION, SET WIRE DISC TO CRIMP HEIGHT REFERENCE SETTING FOR LARGEST WIRE SIZE. CRIMP HEIGHT REFERENCE SETTINGS GREATER THAN THE VALUE SHOWN MAY CAUSE DAMAGE TO THE CRIMP TOOLING, REFER TO THE INSTRUCTION SHEET FOR PROPER SETUP AND ADJUSTMENTS.

LOC	DIST	REVISIONS			
A	66	REV	DATE	BY	APPV
		-	SEE SHEET 1	-	-

-	1	1	2119082-3	CAM, SNAIL, INSULATION ADJUSTMENT	244	
-	1	1	2079764-1	WASHER, WAVE SPRING, CREST-TO-CREST	243	
-	1	1	2119083-1	RETAINER, INSULATION DIAL	242	
-	1	1	7-18023-7	SCR, SKT HD CAP M3 X 4.0	241	
-	-	1	2119580-1	MECHANICAL FEED ASSEMBLY	239	
-	1	-	2844940-1	AIR FEED MODULE	238	
-	REF	REF	994970-2	COUNTER, MAGNETIC	164	
-	1	-	2119641-2	FEED CAM, AIR FEED	151	
-	1	1	2168083-8	SCR, SKT HD CAP, RoHS, M4 X 16	144	
-	4	4	2168083-9	SCR, SKT HD CAP, RoHS, M4 X 20	143	
-	-	1	2119653-2	FEED CAM, POST FEED	142	
-	1	1	1-1803583-0	APPLICATOR BASIC ASSEMBLY, SF	141	
-	1	1	1803516-1	RAM ASSEMBLY, SF PACIFIC	140	
-	1	1	2119955-1	ASSY, LUBRICATOR, SIDE FEED	113	
-	1	1	2844908-1	SCREW, LOCKING	99	
-	1	1	2844907-1	POST, LOCKING	98	
-	1	1	455888-4	SPACER, CRIMPER	82	
-	1	1	22278-8	SPRING, COMPRESSION	77	
-	1	1	854769-4	HOLDER, INS	74	
-	1	1	1803607-3	DOCUMENTATION PACKAGE	71	
-	1	1	2119740-1	TAG, IDENTIFICATION	67	
-	2	2	2168078-1	SCREW, DRIVE, RH, RoHS, 2 x .188	66	
-	1	1	5-18022-5	SCR, HEX HD CAP, M4 X 6.0	59	
-	1	1	21028-2	PIN, SLOTTED SPRING .062 X .250	58	
-	1	1	1338685-1	PAWL, FEED	56	
-	2	2	1-2168083-0	SCR, SKT HD CAP, RoHS, M4 X 10	53	
-	1	1	1803382-6	HOLD DOWN, SPRING LOADED	50	
-	1	2	18023-9	SCR, SKT HD CAP M4 X 6.0	49	
-	-	1	2119652-1	FEED CAM, PRE FEED	48	
-	1	1	1803602-1	SCR, BHSC, RoHS (M8 X 25)	41	
-	1	1	1752356-1	SUPPORT, TERMINAL	34	
-	2	2	2079383-5	SCR, BHSC, RoHS (M4 X 20)	33	
-	2	2	2-2844962-8	SPACER, CYLINDRICAL, STRIP GUIDE	30	
-	1	1	2844992-1	ASSEMBLY, STRIP GUIDE	29	
-	1	1	1-455888-5	SPACER, CRIMPER	28	
-	1	1	1320928-2	STRIP GUIDE	24	
-	1	1	2168083-2	SCR, SKT HD CAP, RoHS, M4 X 8.0	21	
-	2	2	1-18028-2	WASHER, FLAT, REG M4	20	
-	1	1	2119533-1	STRIPPER, SIDE FEED	19	
-	1	1	2119806-1	INSERT, SHEAR	13	
-	1	1	3-22280-3	SPRING, COMPRESSION	12	
-	1	1	1-356885-4	STOP, SHEAR	11	
-	1	1	2119805-1	SHEAR HOLDER, FRONT	10	
-	1	1	1803095-1	FLOATING SHEAR, FRONT	9	
-	1	1	1	7-1633932-5	ANVIL, COMBINATION	8
-	-	-	-	-	7	
-	-	-	-	-	6	
-	1	1	2119780-7	DEPRESSOR, SHEAR	5	
-	1	1	5-238011-2	BLOCK, CRIMPER SPACER	4	
-	1	1	1803242-1	CRIMPER, INSULATION F PREMIUM	3	
-	-	-	-	-	2	
-	1	1	1	6-1333281-5	CRIMPER, WIRE PREMIUM	1

PACIFIC VERSION  
Shown on sheets 3 of 4 & 4 of 4  
(Atlantic version shown on sheets 1 of 4 & 2 of 4)

DIMENSIONS:		TOLERANCES UNLESS OTHERWISE SPECIFIED:		OWN J. HOU 29AUGUST2014	STE TE Connectivity Harrisburg, PA 17105-3608
mm	0 PLC ± 1 PLC ± 2 PLC ± 3 PLC ± 4 PLC ±	±	±	CHK Y. YIN 29AUGUST2014	
MATERIAL:		FINISH:		APVD U. GUO 29AUGUST2014	NAME Ocean Side Feed Applicator
SCALE 1:2		SHEET 3 OF 4		WEIGHT	RESTRICTED TO
Customer Accessible Production Drawing		SCALE 1:2 SHEET 3 OF 4		REV H	

LOC		DIST		REVISIONS			
A	66	P	LYR	DESCRIPTION	DATE	OWN	APVD
		-		SEE SHEET 1			

# FEED TYPE MECHANICAL

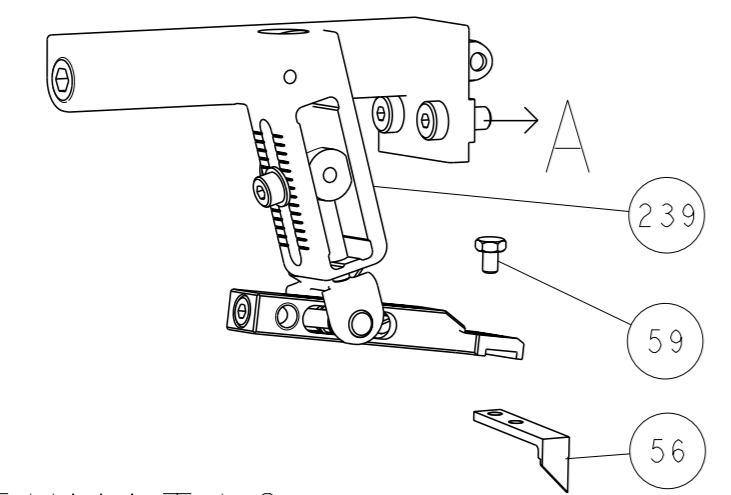

## PNEUMATIC

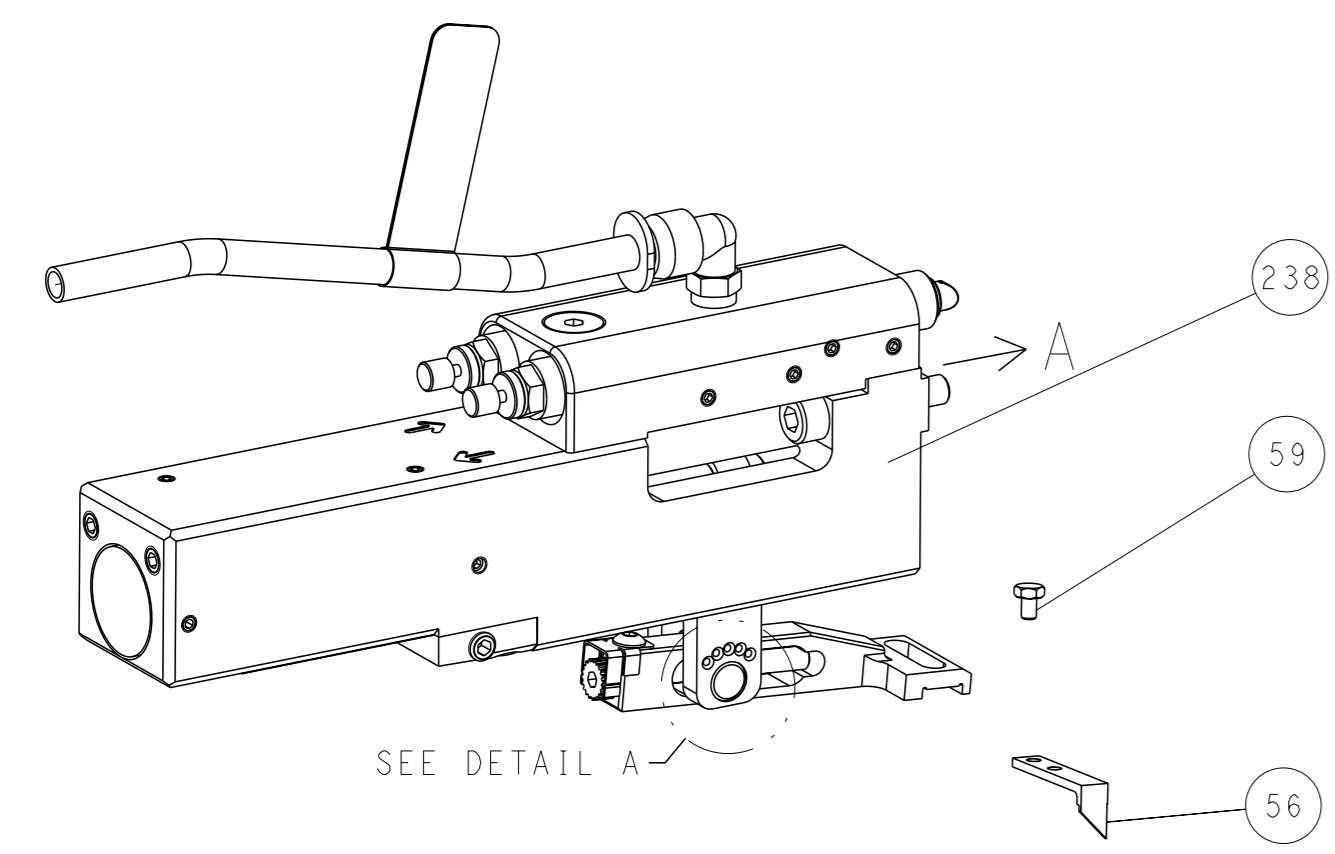

## FEED SPRING SETTING POSITION (SHOWN FROM REAR SIDE)

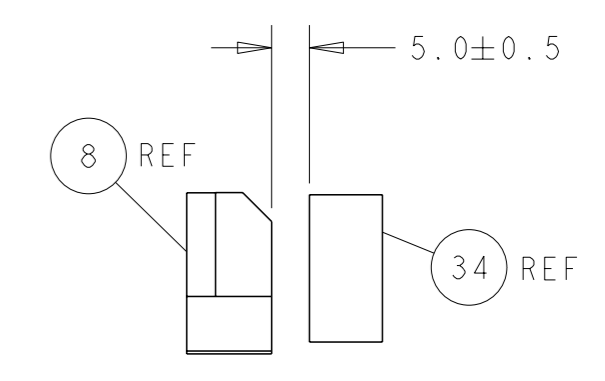
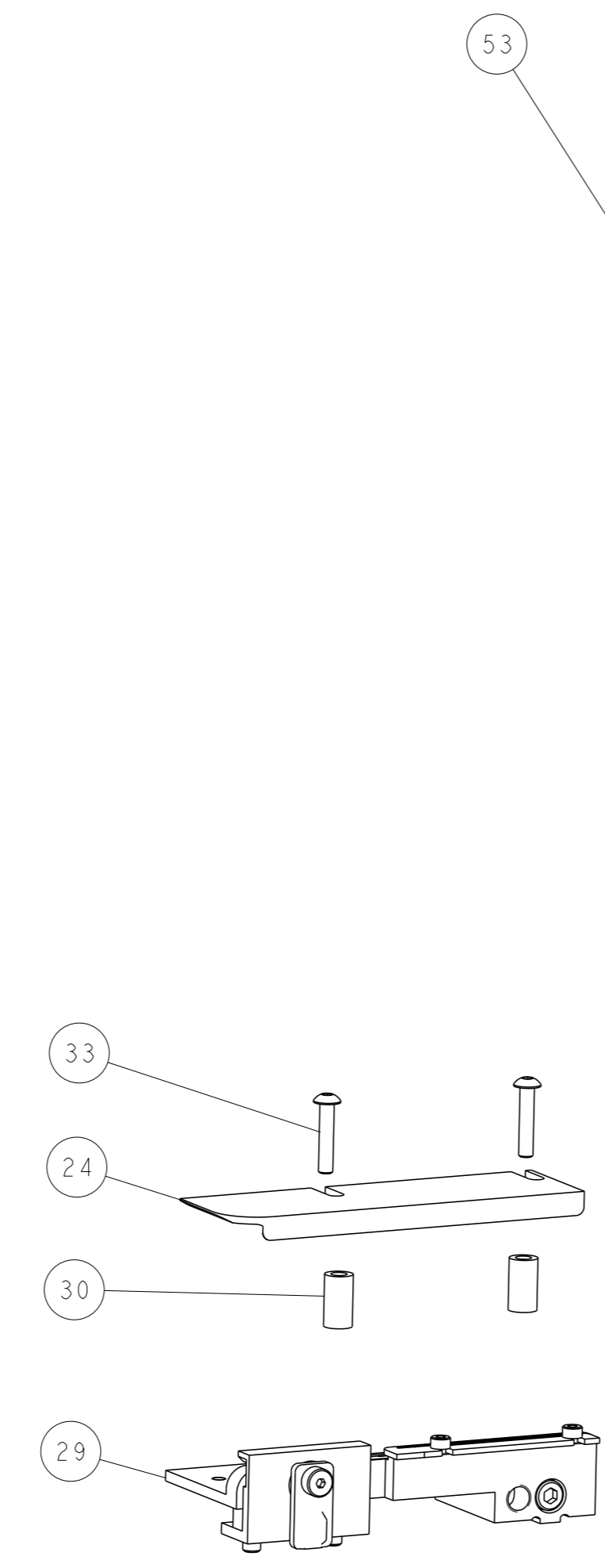
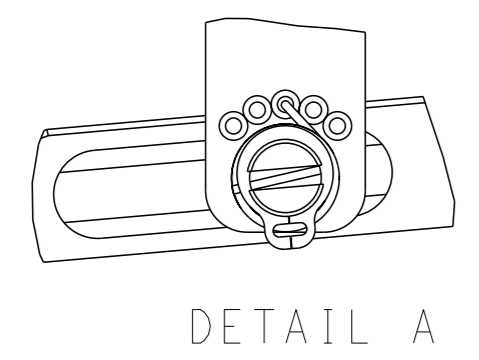

TERMINAL SUPPORT LOCATION

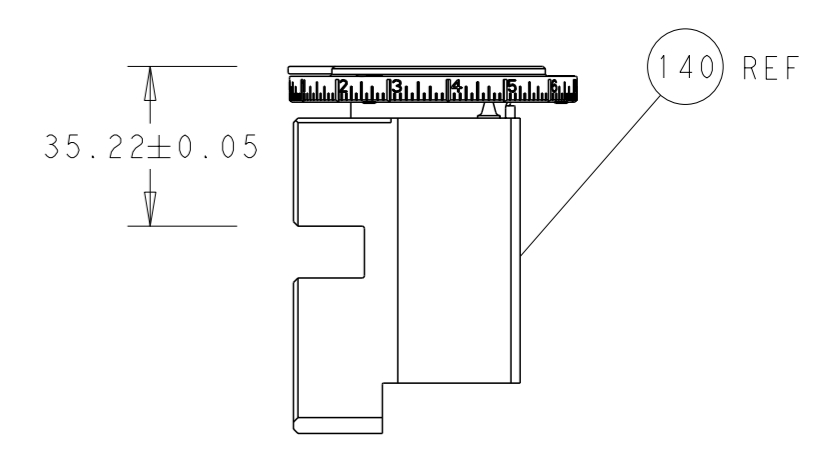

RAM SET-UP

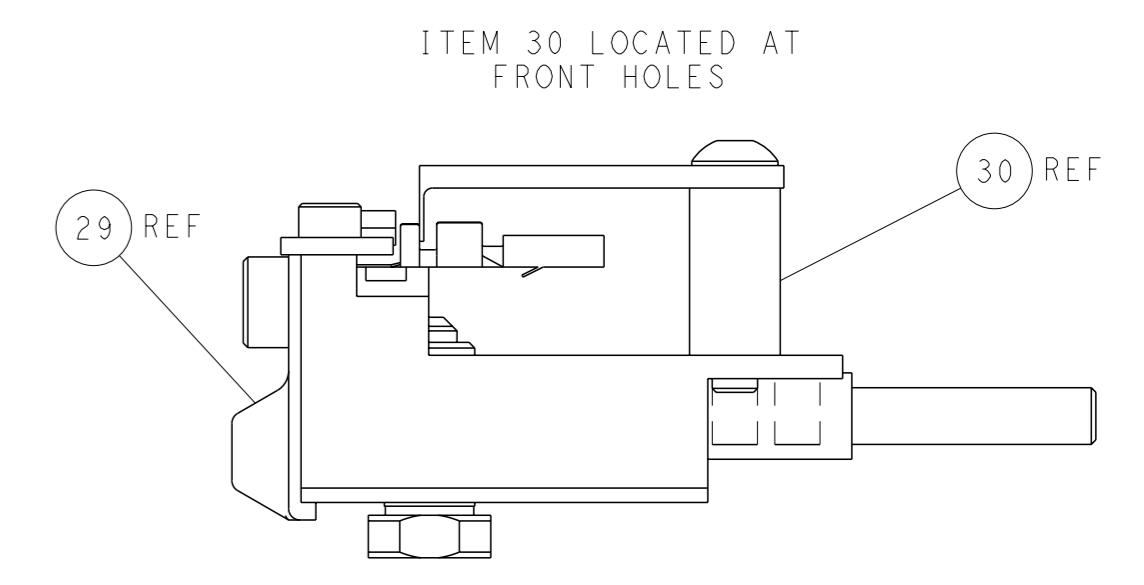

FEED TRACK POSITION GUIDE BY INSULATION BARREL

# CAM POSITIONS

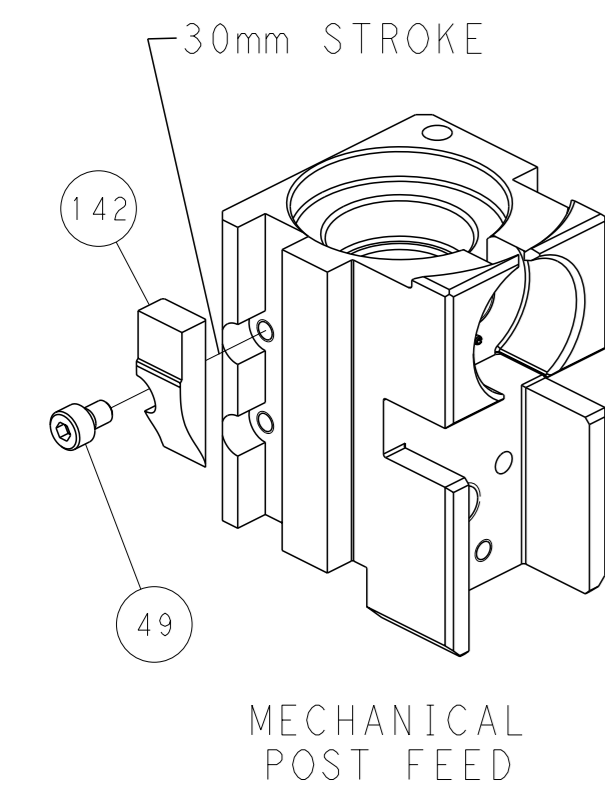

MECHANICAL POST FEED

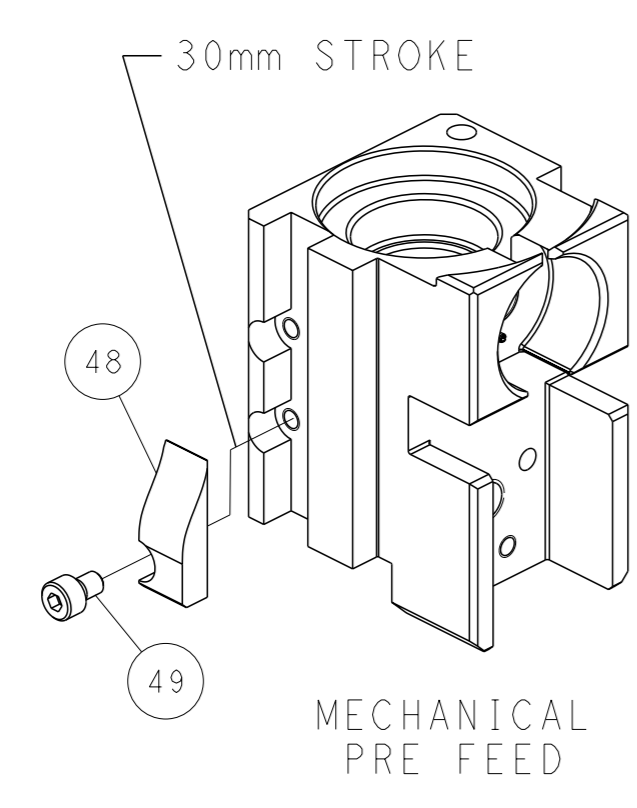

MECHANICAL PRE FEED

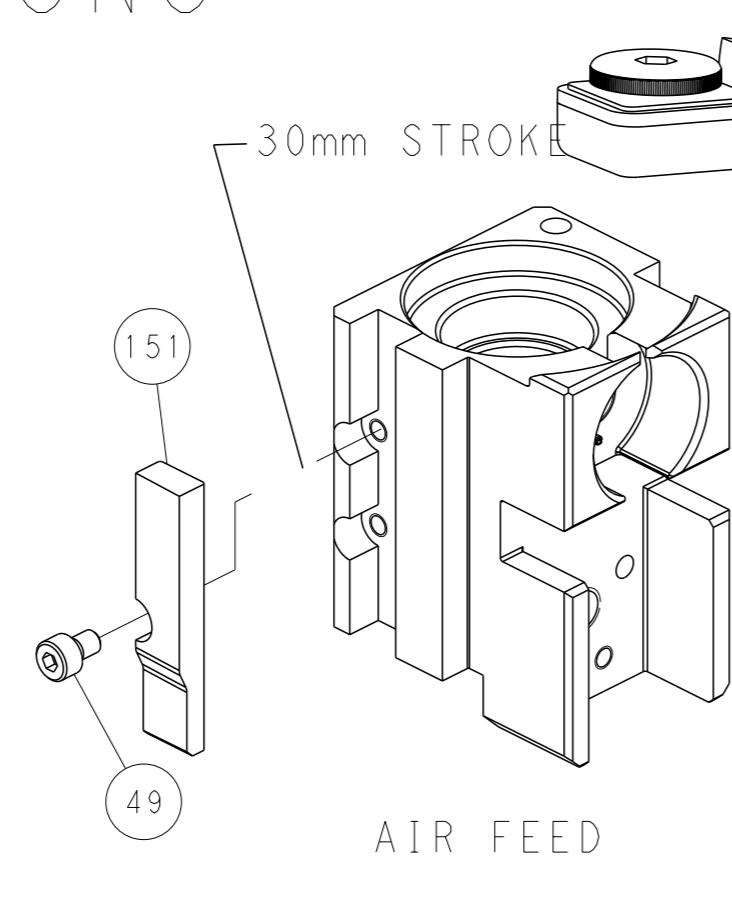

AIR FEED

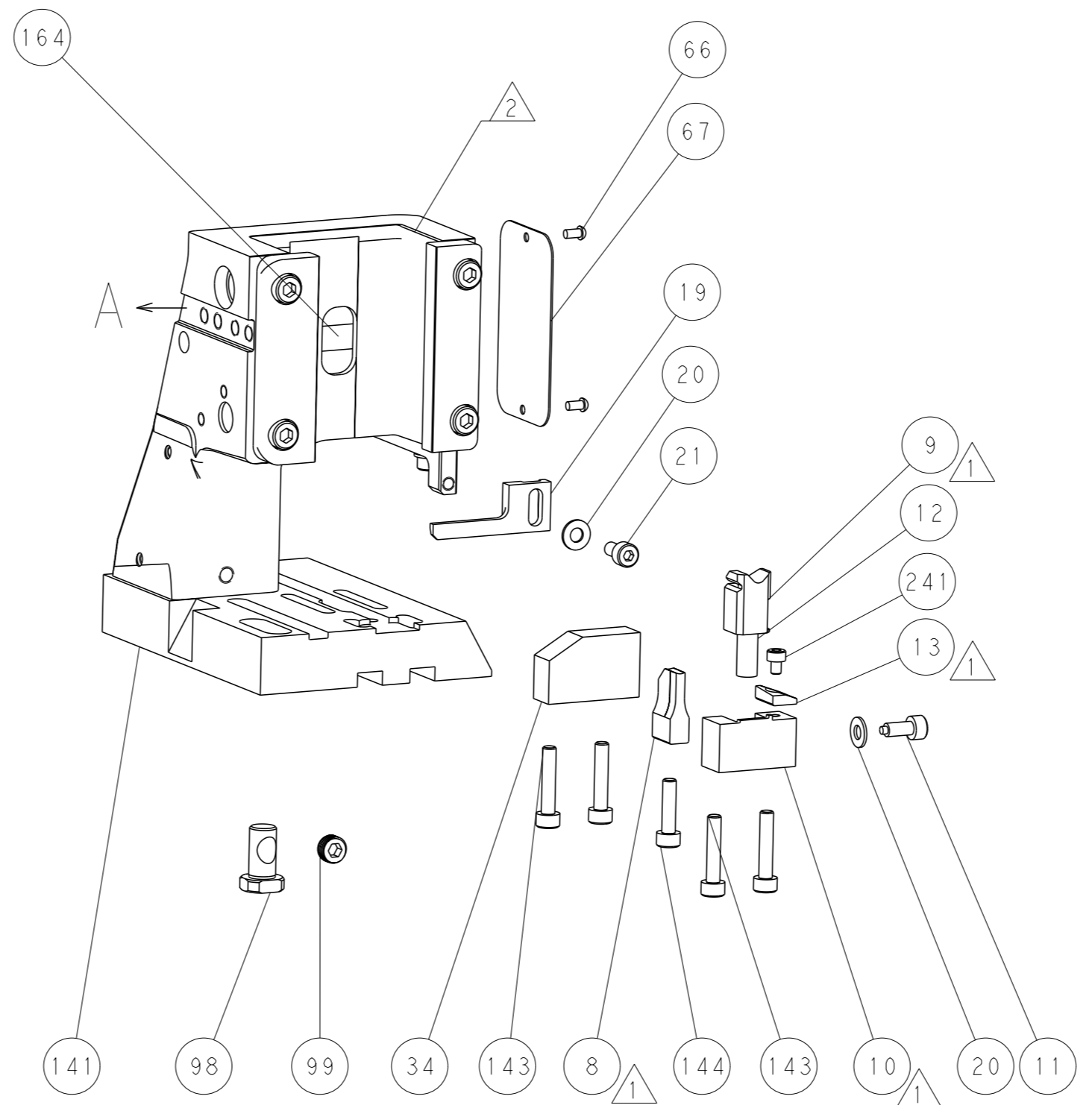

**PACIFIC VERSION**  
 Shown on sheets 3 of 4 & 4 of 4  
 (Atlantic version shown on sheets 1 of 4 & 2 of 4)

<small>THIS DRAWING IS A CONTROLLED DOCUMENT FOR TYCO ELECTRONICS CORPORATION. IT IS SUBJECT TO CHANGE AND THE CONTROLLER'S ENGINEERING DEPARTMENT SHOULD BE CONTACTED FOR THE LATEST REVISION.</small>		OWN: J. HOU CHK: Y. YIN APVD: H. GUO DATE: 29AUGUST2014 PRODUCT SPEC: - APPLICATION SPEC: - WEIGHT: - MATERIAL: -	DATE: 29AUGUST2014 NAME: Ocean Side Feed Applicator SIZE: A1 CAGE CODE: 00779 DRAWING NO: C=2266485 SCALE: 1:2 SHEET: 4 of 4 REV: H	TE Connectivity Harrisburg, PA 17105-3608
---------------------------------------------------------------------------------------------------------------------------------------------------------------------------------------------------------	--	----------------------------------------------------------------------------------------------------------------------------------------	----------------------------------------------------------------------------------------------------------------------------------------------------------	----------------------------------------------