

**Features and Benefits**

- Magnetic technology offers robust performance.
- 100% Non-contacting design (no bearings or bushings) provides an extremely long life and is tolerant to harsh environments.
- Simple two piece design (target magnet + encoder) for easy alignment and installation.
- Bi-directional two channel incremental quadrature output. Option for differential RS422 compatible output.
- Mounting holes for a 2-bolt pattern 1.811" BHC x 0.125" O.D.
- Target magnet for standard shaft sizes from 2 mm to 1/2". Custom bore sizes available.
- Options for 32 - 2500 pulse per channel per revolution.
- Customizable lead wires, cables, and or connectors.

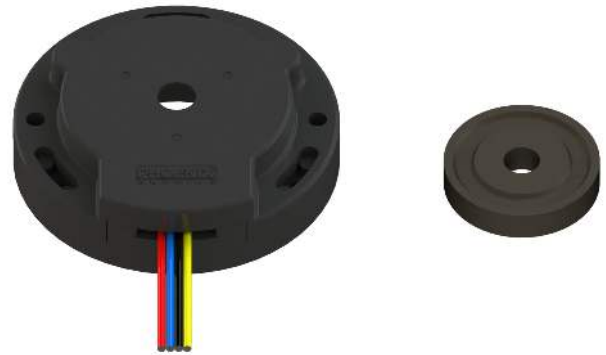

**Kit - Encoder with Target Magnet**  
Shown with shaft pass through hole and single ended wiring  
Wire color order varies with part configuration

**Application Example**

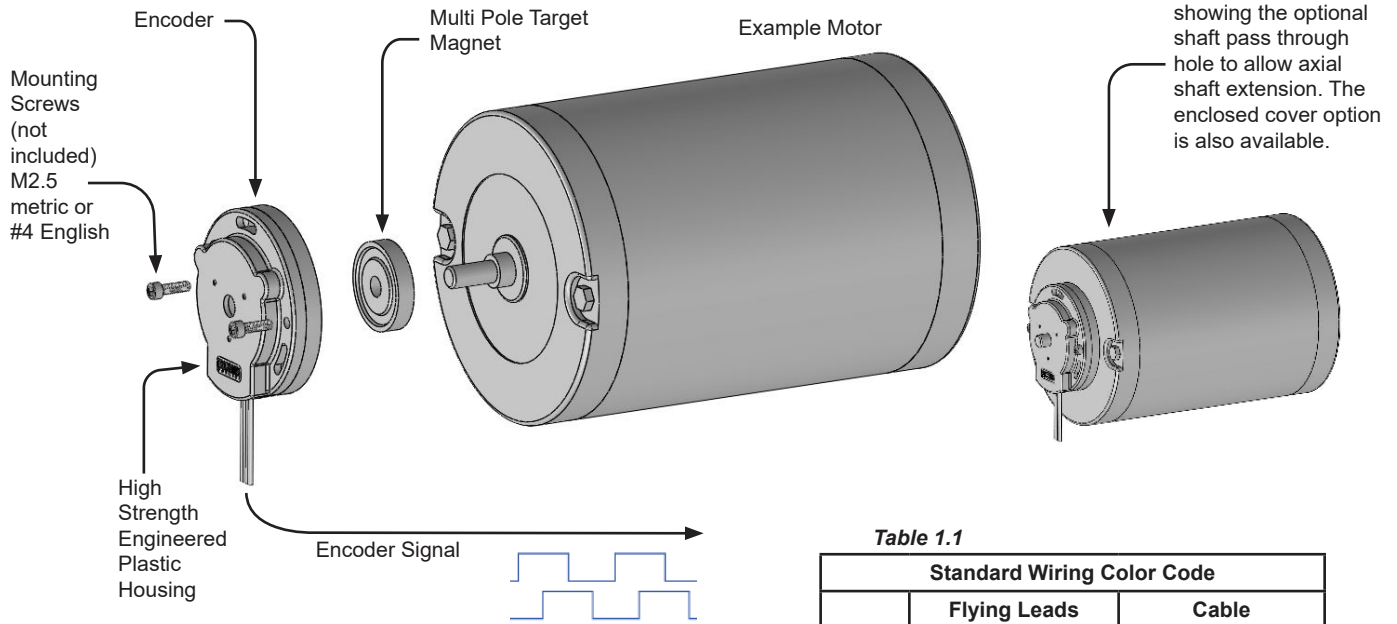

**Table 1.1**

| Standard Wiring Color Code |              |        |        |
|----------------------------|--------------|--------|--------|
|                            | Flying Leads | Cable  |        |
| Single Ended               | <b>Vcc</b>   | Red    | Red    |
|                            | <b>Gnd</b>   | Black  | Black  |
|                            | <b>Ch A</b>  | Yellow | Brown  |
|                            | <b>Ch B</b>  | Blue   | Orange |

Other colors available upon request.  
Contact [sales@phoenixamerica.com](mailto:sales@phoenixamerica.com).

**Absolute Maximum Ratings**

Table 2.1

| Characteristic           | Symbol    | Rating     | Units |
|--------------------------|-----------|------------|-------|
| Forward Supply Voltage   | $V_{CC}$  | 12         | V     |
| Reverse Supply Voltage   | $V_{RCC}$ | -0.3       | V     |
| Storage Temperature      | $T_S$     | 150        | °C    |
| ESD (HMB, 100pF/1.5Kohm) |           | 2          | kV    |
| Operating Temperature    |           | -40 to 125 | °C    |

**Electrical Specifications - ( $V_{CC}= 5V$ , Ambient Temperature= 23 °C)**

Table 2.2

| Characteristic   | Symbol    | Min. | Typ. | Max. | Unit |
|------------------|-----------|------|------|------|------|
| Supply Voltage   | $V_{CC}$  | 3.3  | 5    | 6    | V    |
| Supply Current   | $I_{CC}$  | -    | 14   | 20   | mA   |
| Duty Cycle       | -         | 40   | 50   | 60   | %    |
| Phase            | -         | 70   | 90   | 110  | °e   |
| Output Frequency | $f_{out}$ | -    | -    | 42   | kHz  |

**Output Waveforms**

*Single Ended*

**Clockwise Rotation**

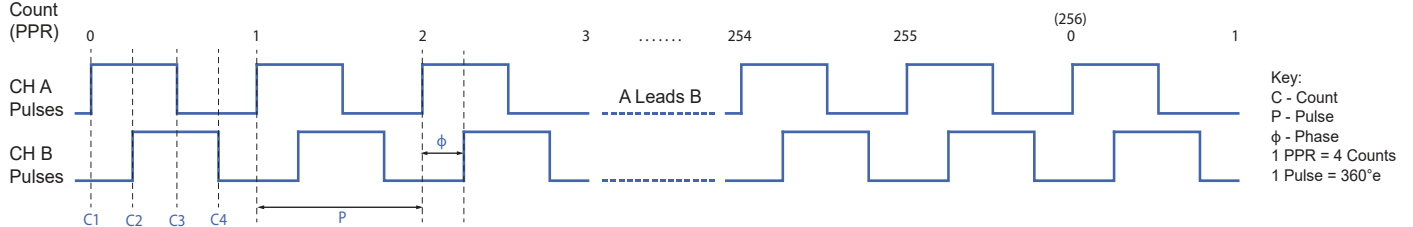

*Z Option*

**Clockwise Rotation**

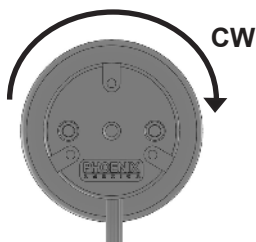
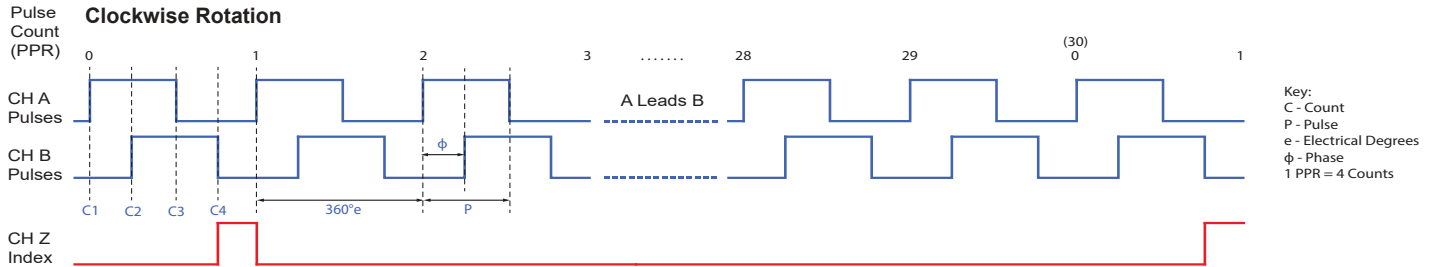

Channel A leads to Channel B for clockwise shaft rotation (shaft rotation is defined when looking at the branded face of the encoder).

**Electrical Circuit**

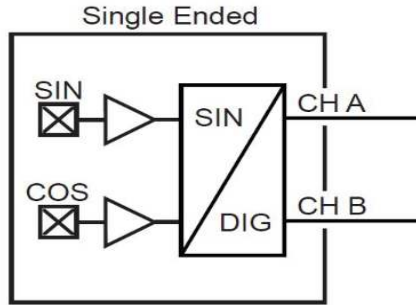

**Encoder Physical Outline**

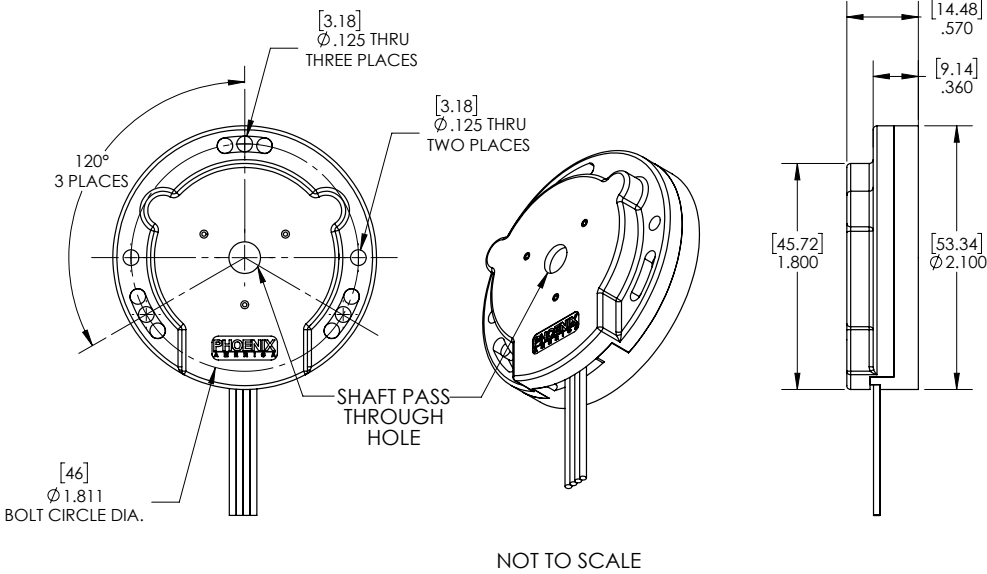

**Table 3.1**

| Motor Shaft Diameter | Shaft Pass Through Hole Size (options/recommendation) |          |
|----------------------|---|----------|
| -                    | No Hole   |          |
| 2 mm                 | 2.06 mm   | 0.081 in |
| 3 mm                 | 3.06 mm   | 0.120 in |
| 1/8 in               | 3.26 mm   | 0.127 in |
| 5/32 in              | 4.06 mm   | 0.160 in |
| 4 mm                 | 4.06 mm   | 0.160 in |
| 3/16 in              | 4.83 mm   | 0.190 in |
| 5 mm                 | 5.06 mm   | 0.199 in |
| 6 mm                 | 6.06 mm   | 0.239 in |
| 1/4 in               | 6.40 mm   | 0.252 in |
| 7 mm                 | 7.06 mm   | 0.278 in |
| 5/16 in              | 8.05 mm   | 0.317 in |
| 8 mm                 | 8.05 mm   | 0.317 in |
| 3/8 in               | 9.59 mm   | 0.378 in |
| 10 mm                | 10.06 mm  | 0.396 in |
| 12 mm                | 12.06 mm  | 0.475 in |
| 1/2 in               | 12.76 mm  | 0.502 in |

Other shaft pass through hole sizes available upon request. Contact [sales@phoenixamerica.com](mailto:sales@phoenixamerica.com).

**Encoder Mounting Guidelines**

Concentricity of the encoder housing to the target magnet is critical for optimal encoder performance. Considering the following during the design phase will ensure concentricity and ease of assembly.

- Tight molding tolerances allow for the outside diameter of the encoder to be used to locate the encoder housing concentric to the motor shaft and target magnet. A machined pocket on the motor endbell works well for alignment. Recommended pocket is 0.015" to 0.020" deep and 2.11" in diameter.
- Extending the shaft through the optional shaft pass through hole is an easy way to align the encoder housing to the motor shaft and target magnet. Simply position the encoder so that the shaft is centered concentrically in the shaft pass through hole.
- If previous two methods of alignment are not used it is recommended that the encoder be fastened to the motor using #5-40 or M3 mounting screws. The slightly larger diameter of the #5-40 and M3 screws will compensate for some of the tolerance allowed when using the standard recommended #4-40 or M2.5 mounting screws.

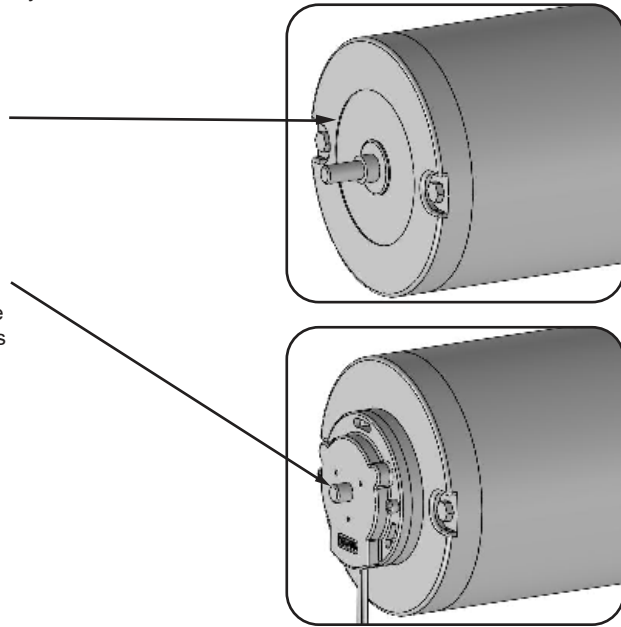

**Target Magnet Physical Outline - Molded (Mounting Style A)**

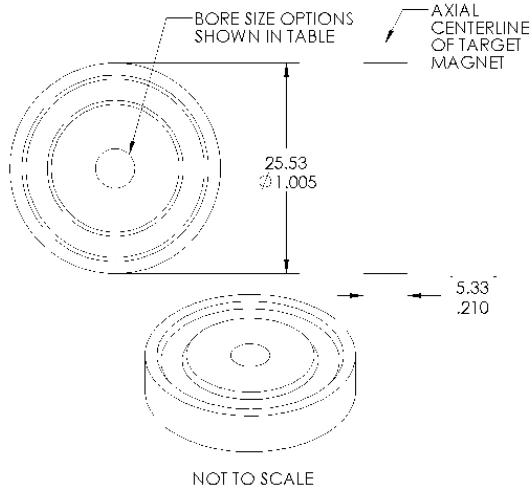

Table 5.1

| Bore Size (inch) | Motor Shaft OD Size (nominal) | NEMA Guide Shaft Tolerance | Magnet Bore MIN. (inch) | Magnet Bore MAX. (inch) |
|------------------|-------------------------------|----------------------------|-------------------------|-------------------------|
| 079              | 2 mm (.0787")                 | +0.0000"/-0.0005"          | .0777                   | .0807                   |
| 118              | 3 mm (.1181")                 |                            | .1171                   | .1201                   |
| 125              | 1/8 in (.1250")               |                            | .1240                   | .1270                   |
| 156              | 5/32 in (.1563")              |                            | .1553                   | .1583                   |
| 157              | 4 mm (.1575")                 |                            | .1565                   | .1595                   |
| 188              | 3/16 in (.1875")              |                            | .1865                   | .1895                   |
| 197              | 5 mm (.1969")                 |                            | .1959                   | .1989                   |
| 236              | 6 mm (.2364")                 |                            | .2354                   | .2384                   |
| 250              | 1/4 in (.2500")               |                            | .2490                   | .2520                   |
| 276              | 7 mm (.2758")                 |                            | .2747                   | .2777                   |
| 313              | 5/16 in (.3125")              |                            | .3115                   | .3145                   |
| 315              | 8 mm (.3150")                 |                            | .3140                   | .3170                   |
| 375              | 3/8 in (.3750")               |                            | .3740                   | .3770                   |
| 394              | 10 mm (.3940")                |                            | .3930                   | .3960                   |
| 473              | 12 mm (.4728")                |                            | .4718                   | .4748                   |
| 500              | 1/2 in (.5000")               |                            | .4990                   | .5020                   |

Other bore sizes available upon request.  
Contact sales@phoenixamerica.com.

**Target Magnet Mounting Guidelines - Molded (Mounting Style A) For Slip Fit Application**

- Proper alignment of the target magnet to the encoder sensing element is critical for optimal encoder performance. Insure that the target magnet is mounted to the specified height shown in the diagram below.
- A machined step on the motor shaft provides a quick and repeatable method for positioning the target magnet. Spacers or other fixturing should be used to properly position the target magnet if no mechanical locating features are on the shaft.
- Various adhesives can be used to bond the target magnet to the motor shaft. Shaft alloys, operating environment, and shaft speed and acceleration should be taken into consideration when selecting an appropriate bonding agent. Loctite threadlockers and retaining compounds have proved effective in bonding the target magnet to the motor shaft. Loctite 263 and 2760 threadlockers and Loctite 638 and 680 retaining compounds are good candidates. These materials have been effective in past experience; testing under actual operating conditions should be used to qualify any bonding material.
- For best results, the motor shaft should be clean and free of any oils, lubricants, or solvents.
- Apply adhesive around the leading edge of the shaft and inside the hole in the target magnet. Use a rotating motion when assembling the target magnet to the shaft to insure good adhesive coverage.
- The use of primers and activators can be used to improve bond strength and cure rate.
- For non-critical applications or for fast bonding for evaluation, a cyanoacrylate adhesive (super glue) can be used. Loctite 401 and 410 have proven effective for quick bonding applications.

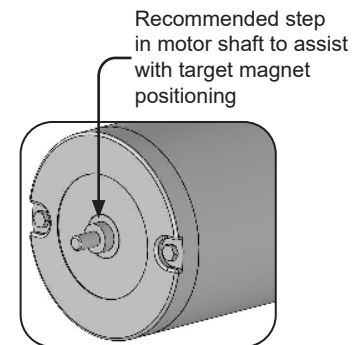
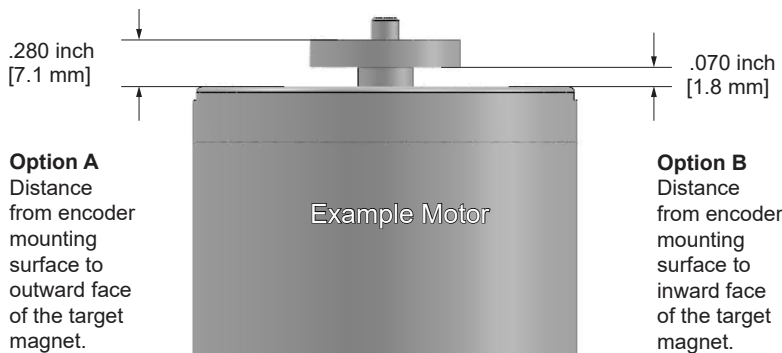

**Target Magnet Physical Outline - Aluminum Hub (Mounting Style B)**

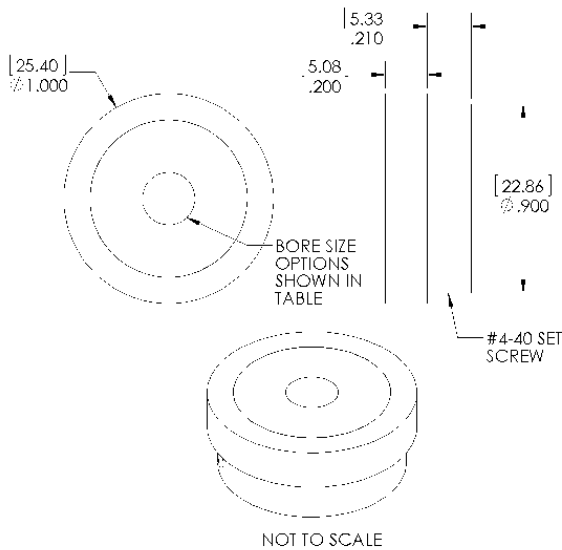

Table 6.1

| Bore Size (.inch) | Motor Shaft OD Size (nominal) | NEMA Guide Shaft Tolerance | Magnet Bore MIN. (inch) | Magnet Bore MAX. (inch) |
|-------------------|-------------------------------|----------------------------|-------------------------|-------------------------|
| 079               | 2 mm (.0787")                 | +0.0000"/-0.0005"          | .0794                   | .0803                   |
| 118               | 3 mm (.1181")                 |                            | .1188                   | .1197                   |
| 125               | 1/8 in (.1250")               |                            | .1257                   | .1266                   |
| 156               | 5/32 in (.1563")              |                            | .1570                   | .1579                   |
| 157               | 4 mm (.1575")                 |                            | .1582                   | .1591                   |
| 188               | 3/16 in (.1875")              |                            | .1882                   | .1891                   |
| 197               | 5 mm (.1969")                 |                            | .1976                   | .1985                   |
| 236               | 6 mm (.2364")                 |                            | .2371                   | .2380                   |
| 250               | 1/4 in (.2500")               |                            | .2507                   | .2516                   |
| 276               | 7 mm (.2758")                 |                            | .2767                   | .2778                   |
| 313               | 5/16 in (.3125")              |                            | .3134                   | .3145                   |
| 315               | 8 mm (.3150")                 |                            | .3159                   | .3170                   |
| 375               | 3/8 in (.3750")               |                            | .3759                   | .3770                   |
| 394               | 10 mm (.3940")                |                            | .3949                   | .3960                   |
| 473               | 12 mm (.4728")                |                            | .4737                   | .4748                   |
| 500               | 1/2 in (.5000")               |                            | .5009                   | .5020                   |

Other bore sizes available upon request.  
Contact sales@phoenixamerica.com.

**Target Magnet Mounting Guidelines - Aluminum Hub (Mounting Style B)**

- Proper alignment of the target magnet to the encoder sensing element is critical for optimal encoder performance. Insure that the target magnet is mounted to the specified height shown in the diagram below.
- A machined step on the motor shaft provides a quick and repeatable method for positioning the target magnet. Spacers or other fixturing should be used to properly position the target magnet if no mechanical locating features are on the shaft.
- While the hub is held in the proper position, use a .50 inch hex wrench to tighten #4-40 set screw.
- For permanent applications, a threadlocker or retaining compound is advised in conjunction with the set screw.

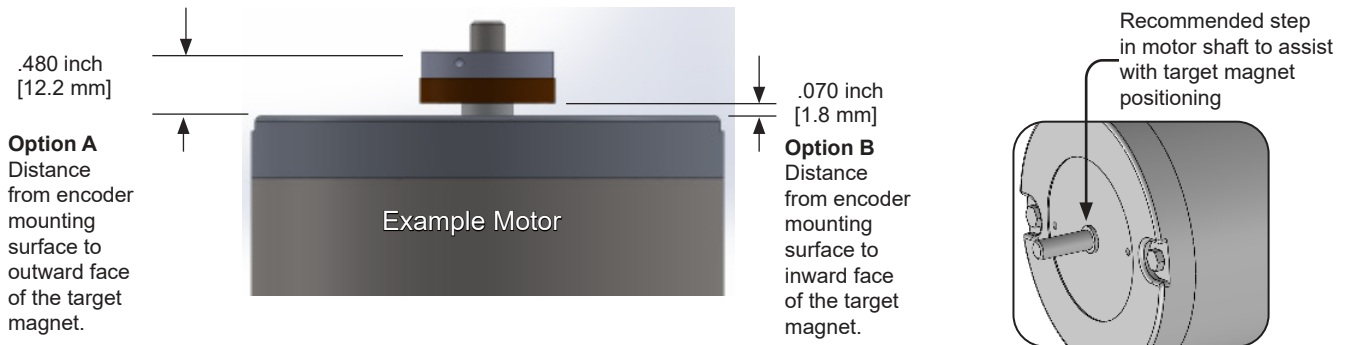

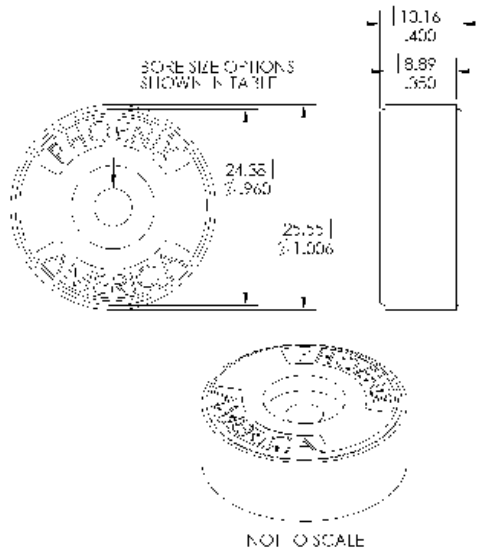

Table 7.1

| Bore Size (.inch) | Motor Shaft OD Size (nominal) | NEMA Guide Shaft Tolerance | Magnet Bore MIN. (inch) | Magnet Bore MAX. (inch) |
|-------------------|-------------------------------|----------------------------|-------------------------|-------------------------|
| 079               | 2 mm (.0787")                 | +0.0000"/-0.0005"          | .0727                   | .0757                   |
| 118               | 3 mm (.1181")                 |                            | .1121                   | .1151                   |
| 125               | 1/8 in (.1250")               |                            | .1190                   | .1220                   |
| 156               | 5/32 in (.1563")              |                            | .1503                   | .1533                   |
| 157               | 4 mm (.1575")                 |                            | .1515                   | .1545                   |
| 188               | 3/16 in (.1875")              |                            | .1815                   | .1845                   |
| 197               | 5 mm (.1969")                 |                            | .1909                   | .1939                   |
| 236               | 6 mm (.2364")                 |                            | .2304                   | .2334                   |
| 250               | 1/4 in (.2500")               |                            | .2440                   | .2470                   |
| 276               | 7 mm (.2758")                 |                            | .2698                   | .2728                   |
| 313               | 5/16 in (.3125")              |                            | .3065                   | .3095                   |
| 315               | 8 mm (.3150")                 |                            | .3090                   | .3120                   |
| 375               | 3/8 in (.3750")               |                            | .3690                   | .3720                   |
| 394               | 10 mm (.3940")                |                            | .3880                   | .3910                   |

Other bore sizes available upon request.  
Contact sales@phoenixamerica.com.

**Target Magnet Mounting Guidelines - Engineered Polymer Hub (Mounting Style H) For Press Fit Application**

- Proper alignment of the target magnet to the encoder sensing element is critical for optimal encoder performance. Insure that the target magnet is mounted to the specified height shown below.
- A machined step on the motor shaft provides a quick and repeatable method for positioning the target magnet. Spacers or other fixturing should be used if no mechanical locating features are on the shaft.
- A chamfered lead in on the shaft will aid in aligning the target magnet.
- Prior to insertion, the motor shaft should be clean and free of any oils, lubricants, or solvents.
- Proper fixtures and support must be used to ensure the target magnet is pressed on straight and aligned with the motor shaft.
- Opposite end of motor shaft should be supported to avoid undue stress on motor bearings during the pressing operation.
- In applications with high torque or environmental extremes, a retaining compound can be used to enhance the strength of the press fit.

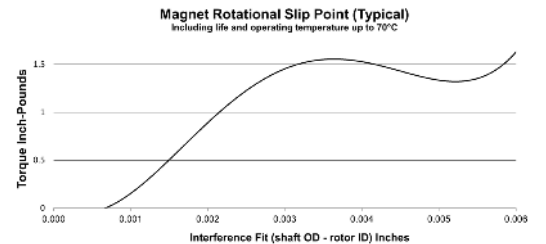
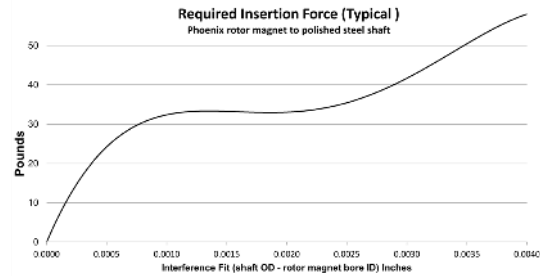

**Target Magnet Physical Outline - Universal Hub (Mounting Style U)**

A universal hub kit is available to provide a range of bore sizes to fit several popular industry shaft diameters.

Kit contents (*not shown to scale*)

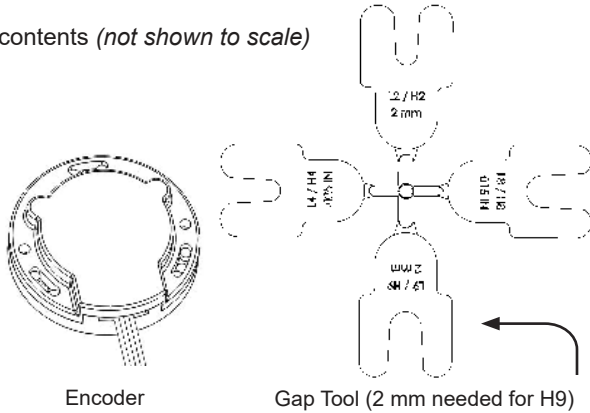

Includes 2 of each size for closed cover option.

Includes 3 of each size for shaft pass through option.

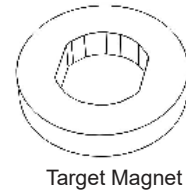
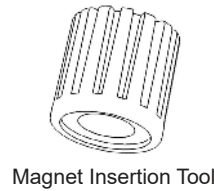
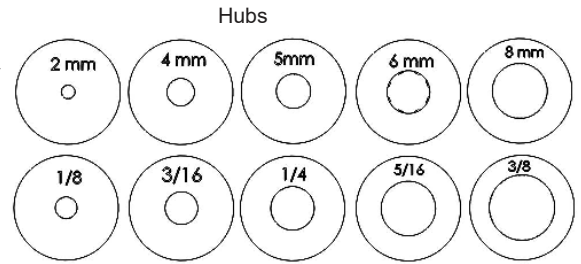

**Assembly Guidelines**

**Without shaft pass-through option**

Step 1

Attach two of the desired hub size on each side of the magnet. Make sure the flats are in-line with each other.

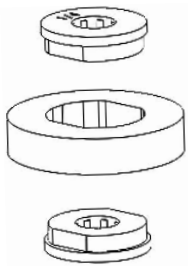

Step 2

Use the insertion tool to push the magnet assembly **straight** onto the shaft until the bottom face of the hub is resting on the gap tool.

*tip* - Support the bottom of the motor with a fixture or holding clamp.

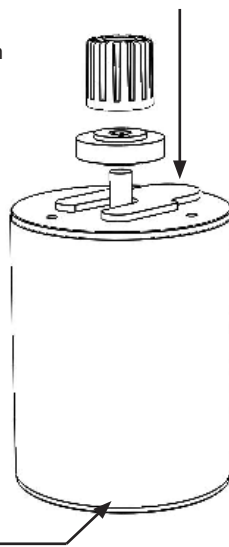

Step 3

Place the encoder onto the motor and secure with #4 or M3 screws.

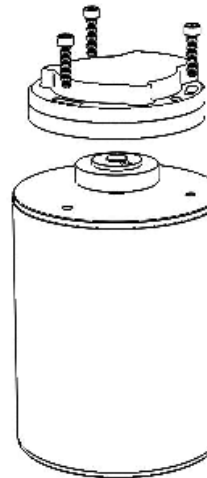

Step 4

Manually spin the shaft to verify that the shaft/magnet is not interfering with the encoder.

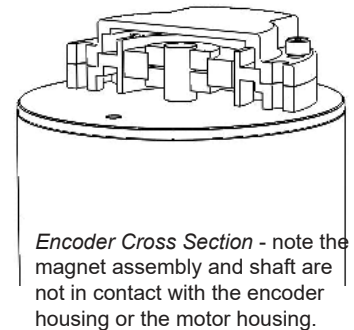

*Encoder Cross Section* - note the magnet assembly and shaft are not in contact with the encoder housing or the motor housing.

**With shaft pass-through option**

Step 2a

Insert an additional hub piece as shown. This is used as a space filler to match the opening in the encoder housing.

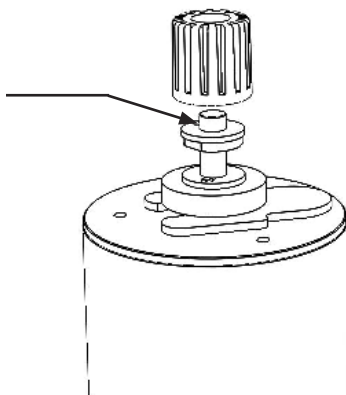

Step 3a

Place the encoder onto the motor and secure with screws.

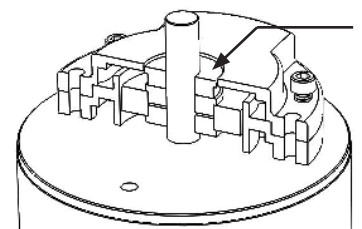
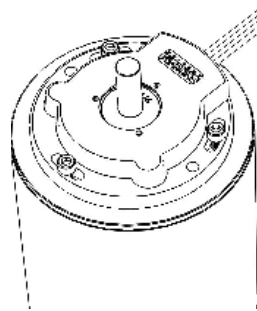

*Encoder Cross Section* - note the top face of the filler hub should be slightly below the top face of the encoder housing as shown by the arrow pointer.



**Wiring** (Single ended option depicted)

FLYING LEADS

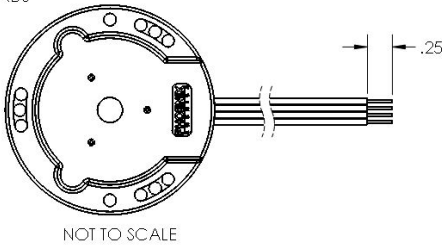

- 24 AWG
- 7x32 Strands, Tinned Copper
- PVC Insulation
- MIL M16878/1
- Temperature Rating: 105°C

CABLE

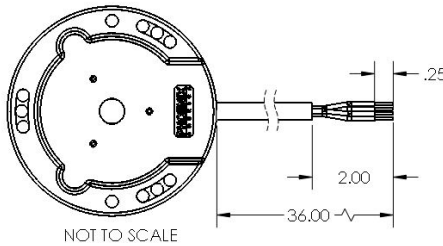

- 24 (or 26) AWG
- 4 (or 6) Conductor with Foil Shield and Drain
- Stranded Tinned Copper
- PVC Insulation
- Grey PVC Jacket
- UL Style 2464, CSA
- Temperature Rating: 105°C

Table 6.1

| Single Ended Wiring |        |        |                   |
|---------------------|--------|--------|-------------------|
|                     | Leads  | Cable  | Connector Pin-Out |
| <b>Ch A</b>         | Yellow | Brown  | 1                 |
| <b>Ch B</b>         | Blue   | Orange | 2                 |
| <b>Gnd</b>          | Black  | Black  | 3                 |
| <b>Vcc</b>          | Red    | Red    | 4                 |
| <b>Z</b>            | Purple |        | 5                 |

Custom lengths and insulation materials available. Contact [sales@phoenixamerica.com](mailto:sales@phoenixamerica.com).

**Connector Options** (Single ended option depicted)

Molex Mini-Fit Jr. (Male)

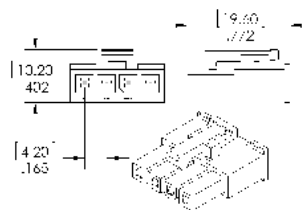

Molex Mini-Fit Jr. (Female)

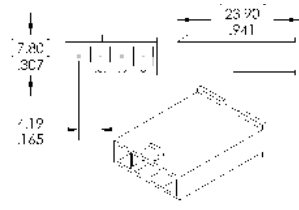

TE AmpModu MTE (Male)

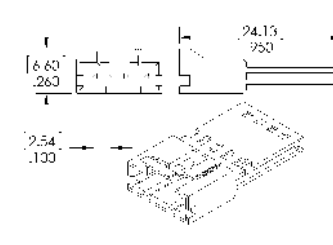

TE AmpModu MTE (Female)

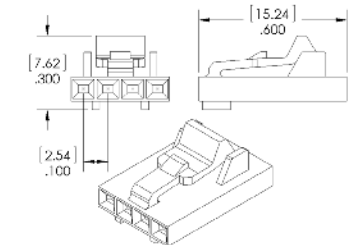

Need a different connector? Contact [sales@phoenixamerica.com](mailto:sales@phoenixamerica.com).

**Part Number Description**

| Series | PPR  | Bore Size  | Supply Voltage   | Output Type             | Shaft Pass Through Hole                              | Target Magnet Mounting   | Wiring                              | Length (Meters)   | Connector   |
|--------|--|--|------------------|-------------------------|--|--|-------------------------------------|---|---|
| H9     | 0032 0240 1000<br>0040 0250 1024<br>0050 0256 1200<br>0056 0300 1250<br>0060 0360 1280<br>0064 0384 1440<br>0080 0400 1500<br>0096 0480 1600<br>0100 0500 1650<br>0120 0512 1800<br>0128 0600 2000<br>0150 0680 2100<br>0160 0720 2400<br>0180 0768 2500<br>0192 0800<br>0200 0900 | 0079 2mm<br>0118 3mm<br>0125 1/8 in<br>0156 5/32 in<br>0157 4mm<br>0188 3/16 in (default)<br>0197 5mm<br>0236 6mm<br>0250 1/4 in<br>0276 7mm<br>0313 5/16 in<br>0315 8mm<br>0375 3/8 in<br>0394 10mm<br>0473 12mm<br>0500 1/2 in<br>0000 Universal Hub | 05 5 V (default) | A AB - 5V<br>B ABZ - 5V | N None (default)<br>Y Hole size will match Table 4.1 | A AS Molded<br>H Engineered Polymer Hub<br>B Aluminum Hub<br>U Universal Hub | F Flying Leads (default)<br>C Cable | A 5 (19.685)<br>B 0.914 (36") (default)<br>C 1 (39.370)<br>D 2 (78.740) | XX None (default)<br>A1 TE AmpModu M E (Male)<br>A2 TE AmpModu MTE (Female)<br>M1 Molex Mini-Fit Jr. (Male)<br>M2 Molex Mini-Fit Jr. (Female) |

Example: H9-0512-0188-05-B-N-A-F-B-XX