

**RIGHT ANGLE PLUG CRIMP TYPE
CABLE BT3002**

R114.191.300
SERIES SMB

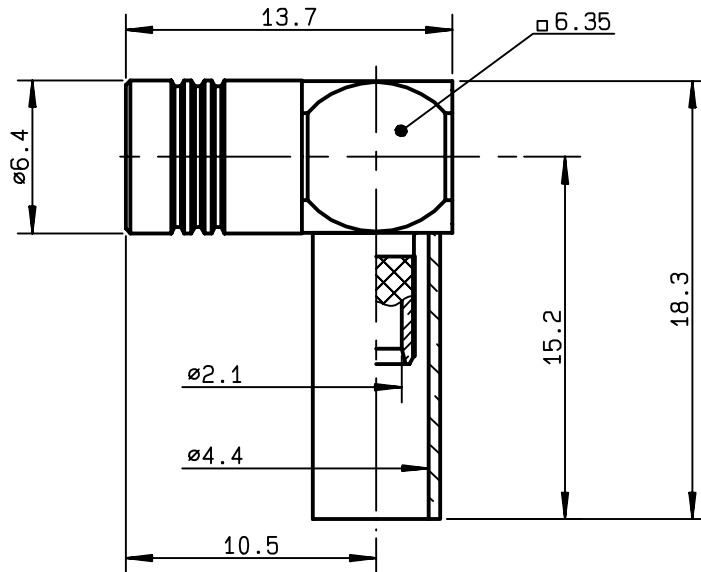

NOMINAL IMPEDANCE	50 Ω	CABLES : BT3002
FREQUENCY RANGE	0-4 GHz	POPE 46431
TEMPERATURE RATING	-65/+165 °C	TZC 750 24
V.S.W.R	NA + x F(GHz)Maxi	
RF INSERTION LOSS	0.5 √F(GHz) dB Maxi	
VOLTAGE RATING	335 Veff Maxi	
DIELECTRIC WITHSTANDING VOLTAGE	1000 Veff Mini	
INSULATION RESISTANCE	1000 MΩMini	OTHERS CHARACTERISTICS
HERMETIC SEAL	NA Atm.cm ³ /s	CABLE RETENTION 100 N Mini
LEAKAGE (pressurized only)	NA	CENTER CONTACT RETENTION
MECHANICAL DURABILITY	500 Cycles	Axial force - mating end 10 N Mini
WEIGHT	3.6 gr	Axial force - opposite end 10 N Mini
SPECIFICATION		Torque NA cm.N Mini
		RECOMMENDED TORQUES
		Mating NA cm.N
		Panel nut NA cm.N
		Clamp nut NA cm.N

CONNECTOR PARTS	MATERIALS	FINISH	(all values are given) in micrometers
BODY	BRASS	GOLD 0.2 OVER NICKEL 2	
OUTER CONTACT	BERYLLIUM COPPER	GOLD 0.5 OVER NICKEL 2	
CENTER CONTACT	BERYLLIUM COPPER	GOLD 1.3 OVER NICKEL 2	
INSULATOR	PTFE	-	
GASKET	-	-	
OTHERS PIECES	BRASS	GOLD 0.2 OVER NICKEL 2	

ISSUE	CREATION DATE	FILE PART-NUMBER
9925B00	01/03/1995	



LELEU

The information given here is subject to change without notice.
Design changes may be in order to improve the product .

Connect to the future



R114.191.300

ISSUE 9925B00 SERIES SMB

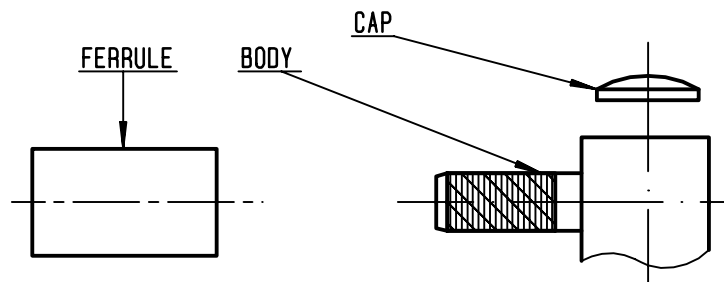

①

Slide onto the cable the ferrule .
Strip the cable .
-
-

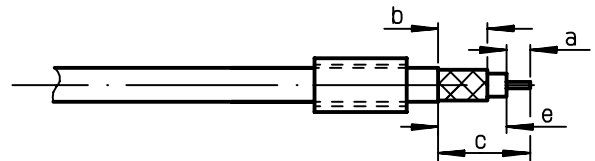

Stripping	a	b	c	d	e
inch	0.059	0.213	0.378	0	0.319
mm	1.5	5.4	9.6		8.1

②

Fan the braid .
Push connector body under the braid .
Slide the ferrule on the braid
(in direction F)
-

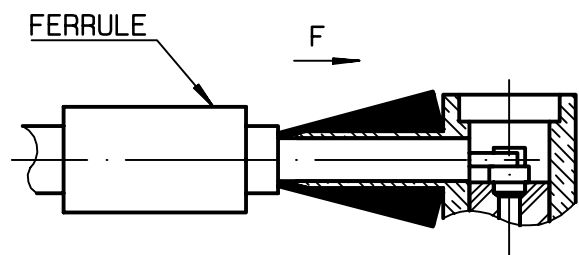

③

Crimp the ferrule with crimping tool R282 211 000 (Hex. : .178) or crimping tool R 282 293 000 (M22520/5-01) + dies R 282 235 009 (M22520/5-09)
Solder inner conductor .

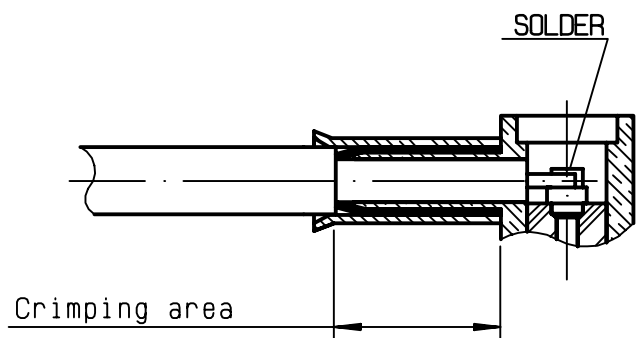

④

Place the cap .
Press cap flush or slightly below surface of body assembly .
-
-
-
-

