

TYPE 1

Single PG/M thread

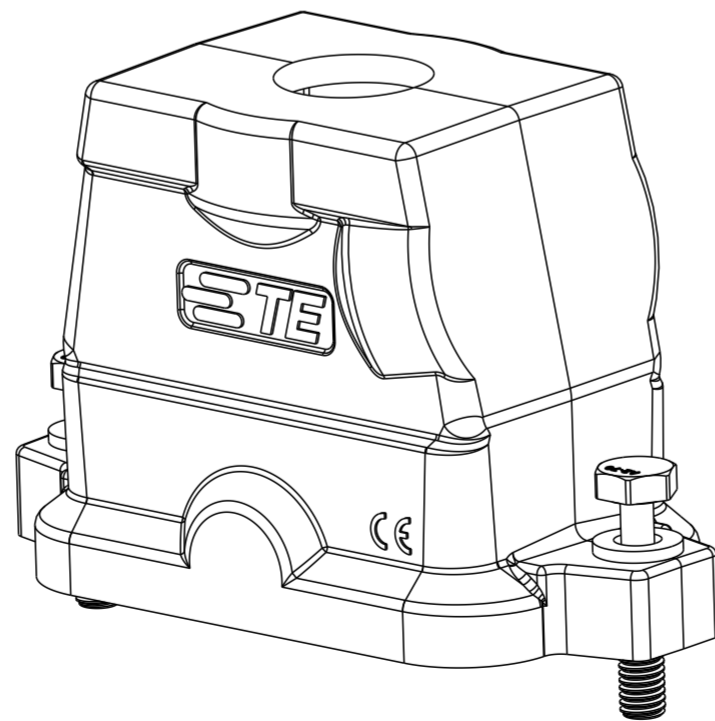
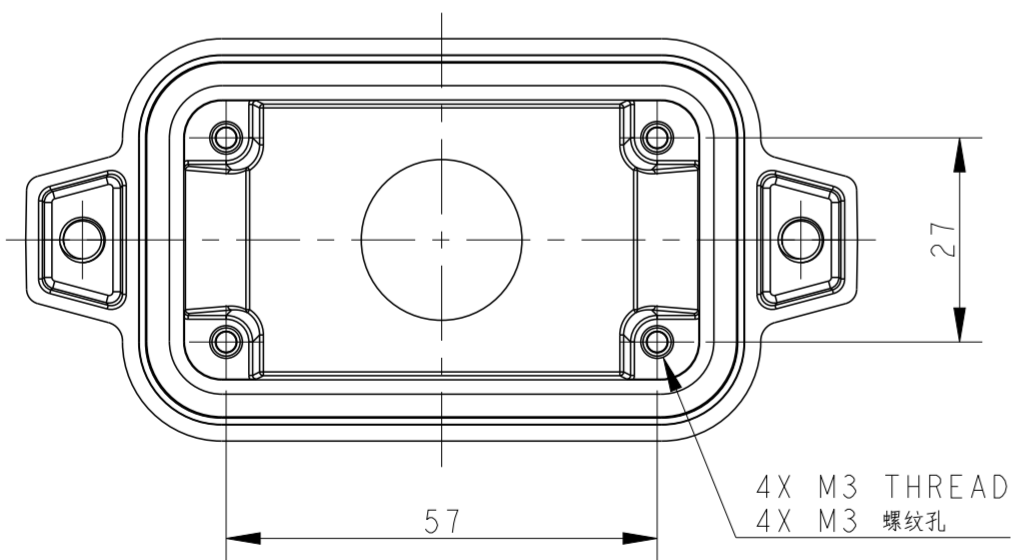
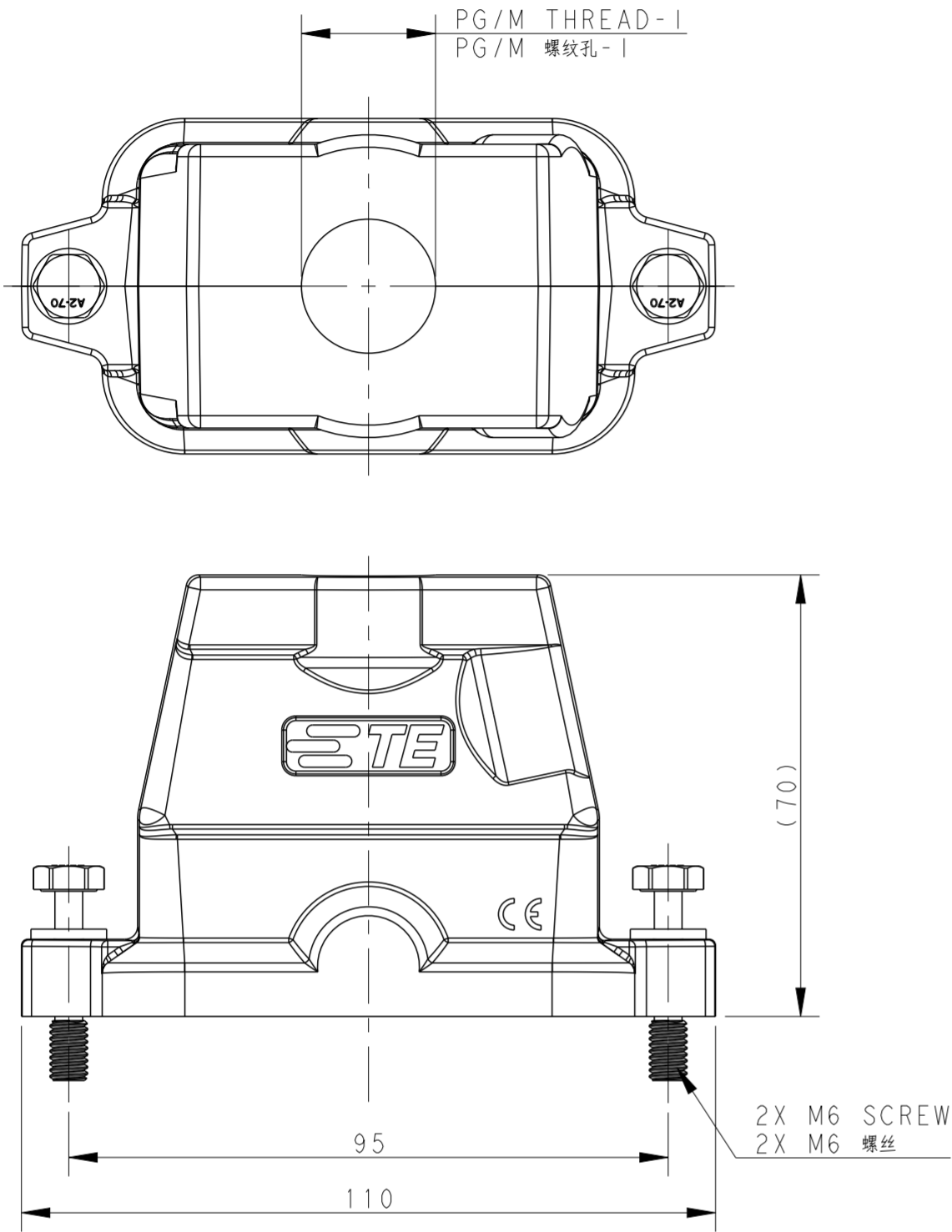

REVISIONS				
P	LTR	DESCRIPTION	DATE	APVD
A		INITIAL RELEASE	14OCT2016	DW CW
B		ECR-20-016312	04JUN2021	BS CW
B1		ECR-22-138033	09MAY2022	AC CW

TYPE 2

Two PG/M threads

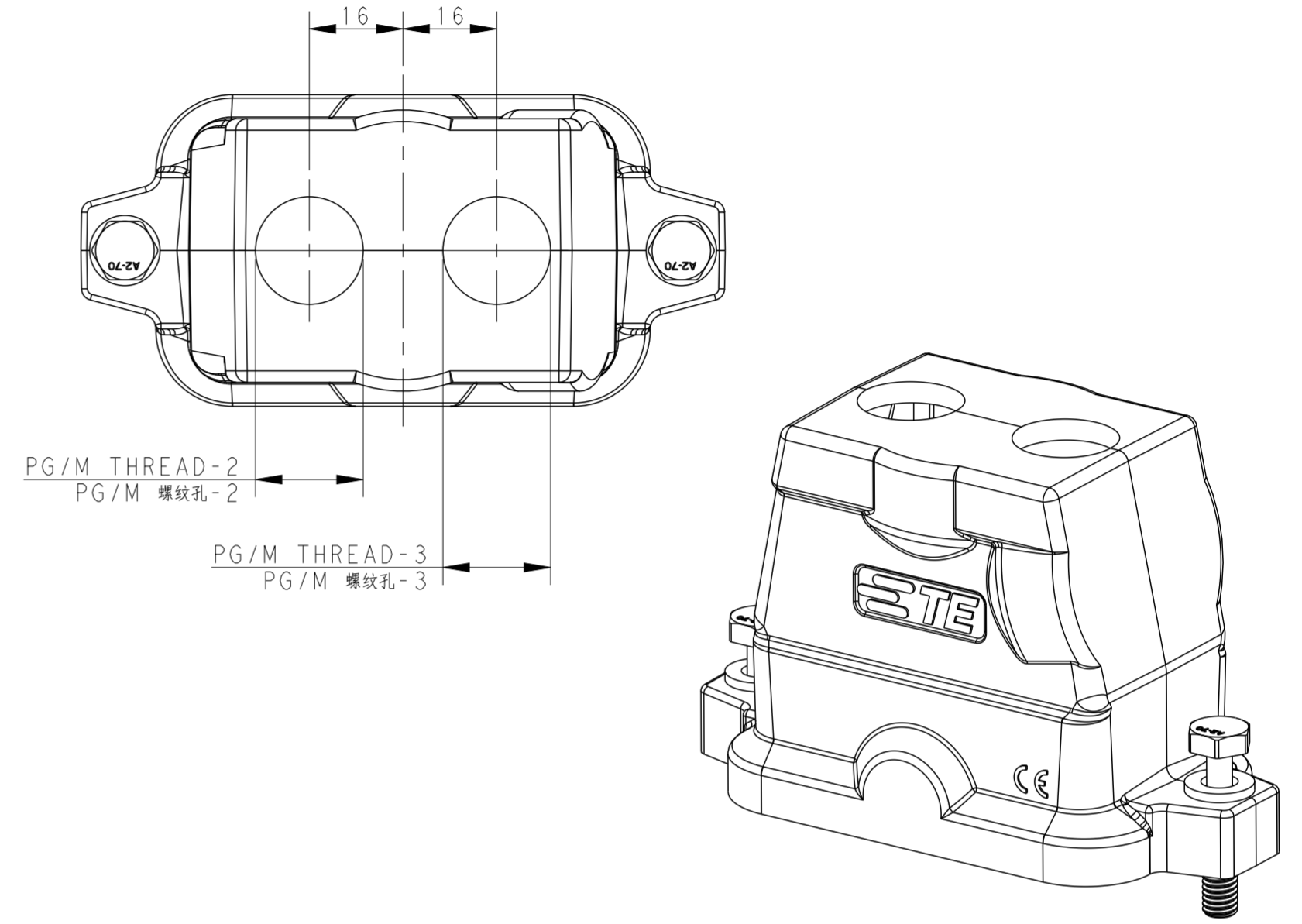

All dimension is same as TYPE 1, except those defined in this TYPE

NOTES:
 1. TECHNICAL CHARACTERISTICS:
 HOOD MATERIAL: DIE CAST ALUMINIUM ALLOY
 SURFACE: SEE TABLE
 DEGREE OF PROTECTION: IP68 (MATED)

注释
 1. 技术参数:
 壳体材料: 铝合金
 表面处理: 见表格
 防护等级: IP68 (配合)

THIS DRAWING IS A CONTROLLED DOCUMENT.		DWN DAVID WANG 14OCT2016 CHK CHRIS WANG 14OCT2016 APVD XIANG XU 14OCT2016	STE TE Connectivity	
DIMENSIONS: mm		PRODUCT SPEC 108-137191	NAME H10BPR-TGHC-PG/M-EMC-C	
TOLERANCES UNLESS OTHERWISE SPECIFIED: 0 PLC ± 1 PLC ± 2 PLC ± 3 PLC ± 4 PLC ± ANGLES ± FINISH		APPLICATION SPEC 114-137191	SIZE A2	RESTRICTED TO -
MATERIAL	-	WEIGHT	CAGE CODE -	DRAWING NO G-T192210XXXX009
CUSTOMER DRAWING		SCALE 1:1	SHEET 1 OF 2	REV B1

THIS DRAWING IS UNPUBLISHED. RELEASED FOR PUBLICATION 20
 © COPYRIGHT 20 BY - ALL RIGHTS RESERVED.

REVISIONS					
P	LTR	DESCRIPTION	DATE	DWN	APVD
-		SEE SHEET 1	-	-	-

NOTES:
SEE SHEET 1

PART NUMBER 料号	DESCRIPTION 描述	PG/M THREAD-3 PG/M 螺纹-3	PG/M THREAD-2 PG/M 螺纹-2	PG/M THREAD-1 PG/M 螺纹-1	TYPE 类型
T1922100220-009	H10BPR-TGHC-2M20-EMC-C H10BPR HOOD,CENTER LOCKING, TOP ENTRY 2M20, POWDER COATED, BLACK H10BPR中部锁定顶出上壳M20 黑色	M20	M20	-	TYPE 2 类型2
T1922102132-009	H10BPR-TGHC-M32-EMC-C H10BPR HOOD,CENTER LOCKING, TOP ENTRY M32, POWDER COATED, GREY H10BPR中部锁定顶出上壳M32 灰色	-	-	M32	TYPE 1 类型1
T1922102129-009	H10BPR-TGHC-PG29-EMC-C H10BPR HOOD,CENTER LOCKING, TOP ENTRY PG29, POWDER COATED, GREY H10BPR中部锁定顶出上壳PG29 灰色	-	-	PG29	
T1922102125-009	H10BPR-TGHC-M25-EMC-C H10BPR HOOD,CENTER LOCKING, TOP ENTRY M25, POWDER COATED, GREY H10BPR中部锁定顶出上壳M25 灰色	-	-	M25	
T1922102121-009	H10BPR-TGHC-PG21-EMC-C H10BPR HOOD,CENTER LOCKING, TOP ENTRY PG21, POWDER COATED, GREY H10BPR中部锁定顶出上壳PG21 灰色	-	-	PG21	
T1922102120-009	H10BPR-TGHC-M20-EMC-C H10BPR HOOD,CENTER LOCKING, TOP ENTRY M20, POWDER COATED, GREY H10BPR中部锁定顶出上壳M20 灰色	-	-	M20	
T1922102116-009	H10BPR-TGHC-PG16-EMC-C H10BPR HOOD,CENTER LOCKING, TOP ENTRY PG16, POWDER COATED, GREY H10BPR中部锁定顶出上壳PG16 灰色	-	-	PG16	
T1922101132-009	H10BPR-TGHC-M32-EMC-C H10BPR HOOD,CENTER LOCKING, TOP ENTRY M32, POWDER COATED, SILVER WHITE H10BPR中部锁定顶出上壳M32 银白色	-	-	M32	
T1922101129-009	H10BPR-TGHC-PG29-EMC-C H10BPR HOOD,CENTER LOCKING, TOP ENTRY PG29, POWDER COATED, SILVER WHITE H10BPR中部锁定顶出上壳PG29 银白色	-	-	PG29	
T1922101125-009	H10BPR-TGHC-M25-EMC-C H10BPR HOOD,CENTER LOCKING, TOP ENTRY M25, POWDER COATED, SILVER WHITE H10BPR中部锁定顶出上壳M25 银白色	-	-	M25	
T1922101121-009	H10BPR-TGHC-PG21-EMC-C H10BPR HOOD,CENTER LOCKING, TOP ENTRY PG21, POWDER COATED, SILVER WHITE H10BPR中部锁定顶出上壳PG21 银白色	-	-	PG21	
T1922101120-009	H10BPR-TGHC-M20-EMC-C H10BPR HOOD,CENTER LOCKING, TOP ENTRY M20, POWDER COATED, SILVER WHITE H10BPR中部锁定顶出上壳M20 银白色	-	-	M20	
T1922101116-009	H10BPR-TGHC-PG16-EMC-C H10BPR HOOD,CENTER LOCKING, TOP ENTRY PG16, POWDER COATED, SILVER WHITE H10BPR中部锁定顶出上壳PG16 银白色	-	-	PG16	
T1922100132-009	H10BPR-TGHC-M32-EMC-C H10BPR HOOD,CENTER LOCKING, TOP ENTRY M32, POWDER COATED, BLACK H10BPR中部锁定顶出上壳M32 黑色	-	-	M32	
T1922100129-009	H10BPR-TGHC-PG29-EMC-C H10BPR HOOD,CENTER LOCKING, TOP ENTRY PG29, POWDER COATED, BLACK H10BPR中部锁定顶出上壳PG29 黑色	-	-	PG29	
T1922100125-009	H10BPR-TGHC-M25-EMC-C H10BPR HOOD,CENTER LOCKING, TOP ENTRY M25, POWDER COATED, BLACK H10BPR中部锁定顶出上壳M25 黑色	-	-	M25	
T1922100121-009	H10BPR-TGHC-PG21-EMC-C H10BPR HOOD,CENTER LOCKING, TOP ENTRY PG21, POWDER COATED, BLACK H10BPR中部锁定顶出上壳PG21 黑色	-	-	PG21	
T1922100120-009	H10BPR-TGHC-M20-EMC-C H10BPR HOOD,CENTER LOCKING, TOP ENTRY M20, POWDER COATED, BLACK H10BPR中部锁定顶出上壳M20 黑色	-	-	M20	
T1922100116-009	H10BPR-TGHC-PG16-EMC-C H10BPR HOOD,CENTER LOCKING, TOP ENTRY PG16, POWDER COATED, BLACK H10BPR中部锁定顶出上壳PG16 黑色	-	-	PG16	

THIS DRAWING IS A CONTROLLED DOCUMENT.

DWN	DAVID WANG	14OCT2016
CHK	CHRIS WANG	14OCT2016
APVD	XIANG XU	14OCT2016
PRODUCT SPEC	108-137191	
APPLICATION SPEC	114-137191	
WEIGHT	-	
CUSTOMER DRAWING	SCALE 1:1	SHEET 2 OF 2

STE TE Connectivity

NAME: H10BPR-TGHC-PG/M-EMC-C

RESTRICTED TO: -

REV: B1