

REVISION(S)			
LTR	DESCRIPTION	INIT	APP'D
O	ECN: 0S60-0226-04	E.T 9/21/04	B.P 9/27/04
A	ECR-06-013536	E.T 6/6/06	V.K 6/6/06

NOTE:

1. MATERIAL:

HEAT SINK: ALUM. (BLACK ANODIZE)  
CLIP: BLACK PEI (UL94-VO)

2. BEFORE THE HEATSINK APPLICATION, THE USER SHOULD IDENTIFY THE SPECIFICATION OF MAXIMUM LOAD ON THE BGA PACKAGE.

HEATSINK TORQUE SPECIFICATIONS CONVERTED TO FORCE.

BARE DIE PACKAGE:

2.5 INCH - LB TORQUE = 7.8 LBS FORCE  
3.0 INCH - LB TORQUE = 9.4 LBS FORCE

FULL SIZE LID PACKAGE:

2.5 INCH - LB TORQUE = 6.3 LBS FORCE  
3.0 INCH - LB TORQUE = 7.6 LBS FORCE

3. REMOVE CLIP WITH REMOVAL TOOL P/N: 1542616-1.

4. RoHS COMPLIANT AND CERTIFIED.

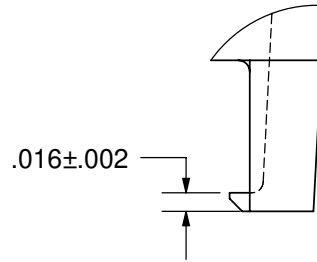
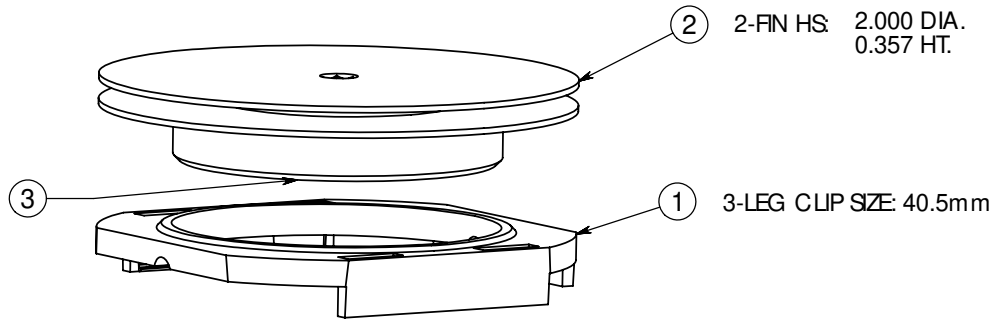

DETAIL A  
SCALE = 6X

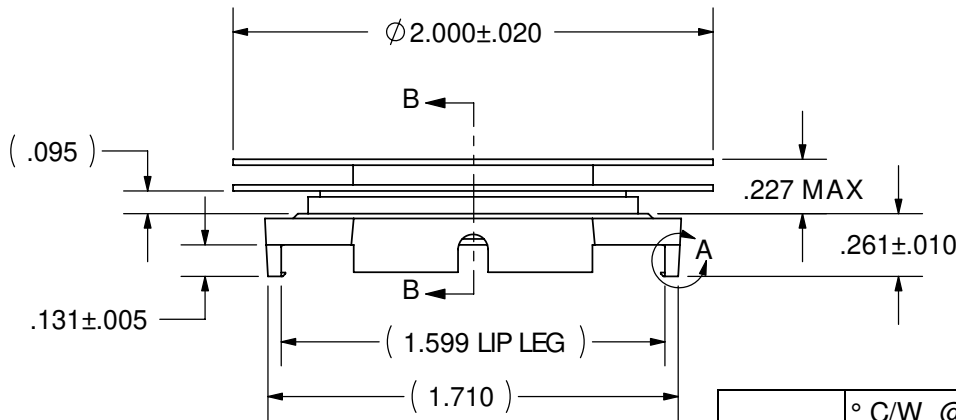

1 3/8 - 27 UNS-2A  
THREAD



SECTION B-B

Power	° C/W @ Ambient	° C/W @ 200 LFM	° C/W @ 400 LFM	° C/W @ 600 LFM
5 Watts	8.91	4.96	3.37	2.72
10 Watts	8.08	5.08	3.33	2.63
15 Watts	7.54	4.99	3.19	2.61

**CUSTOMER DRAWING**

SPECIFICATIONS ARE SUBJECT TO CHANGE WITHOUT NOTICE

ITEM	DESCRIPTION	QTY
1	MOUNTING CLIP	1
2	HEAT SINK	1
3	INTERFACE	1

DO NOT SCALE

<b>tyco</b> / Electronics <small>UNLESS OTHERWISE SPECIFIED TO LEFTRANCES ARE</small>		Attleboro Falls Massachusetts 02763		<small>CONFIDENTIAL PROPERTY OF TYCO ELECTRONICS NOT TO BE DISCLOSED TO OTHERS REPRODUCED OR USED FOR ANY PURPOSES EXCEPT AS AUTHORIZED IN WRITING BY AN AUTHORIZED OFFICIAL OF TYCO. MUST BE RETURNED TO TYCO ON DEMAND, ON COMPLETION OF ORDERS OR OTHER PURPOSES FOR WHICH LENT.</small>		TITLE: <b>40.5mm HEATSINK ASSEMBLY</b>	
<small>DRAWN BY:</small> ETAO	<small>DATE:</small> 9/21/04	<small>MATERIAL:</small> SEE NOTE		<small>DIMENSIONS ARE IN:</small> INCHES	<small>SCALE:</small> 1.25:1	<small>PART NO.:</small> 5-1542007-8	<small>SHEET:</small> 1 OF 1
<small>ENGINEER:</small> B.PETROCELLI	<small>DATE:</small> 9/27/04	<small>FINISH:</small> SEE NOTE		<small>SIZE:</small> A	<small>DWG. NO.:</small> C-5-1542007-8	<small>REV.:</small> A	<small>FILENAME:</small> 
<small>PROJECT:</small> 	<small>SYSTEM:</small> 	<small>INFORM ANGLE PROJECTION:</small> 					