

PART NO.	FIG.	"D1"	"HD"	"D2"	"T" REF.	"E" REF.	"L"	MATERIAL/COLOR
CBHP-1	1	.012 (0.3)	.025 (0.6)	.047 (1.2)	5/16 (7.9)	1/8 (3.2)	1/2 (12.7)	NYLON 4-6, BLACK, RMS-109
CBHP-2	1	.015 (0.4)	.050 (1.3)	.082 (2.1)		11/64 (4.4)	35/64 (13.9)	
CBHP-3S	2	.040 (1.0)	.100 (2.5)	.160 (4.1)		7/32 (5.6)	19/32 (15.1)	SILICONE, BLACK, RMS-123
CBHP-4S	2	.090 (2.3)	.150 (3.8)	.209 (5.3)				
CBHP-5S	2	.140 (3.6)	.200 (5.1)	.261 (6.6)				
CBHP-6S	2	.200 (5.1)	.250 (6.4)	.309 (7.8)		11/64 (4.4)	35/64 (13.9)	
CBHP-7S	3	.261 (6.6)	.312 (7.9)	.355 (9.0)	31/64 (12.3)			
CBHP-8S	3	.320 (8.1)	.375 (9.5)	.420 (10.7)				
CBHP-9S	3	.443 (11.3)	.500 (12.7)	.539 (13.7)				

NOTE: METRIC EQUIVALENT FOR REFERENCE ONLY

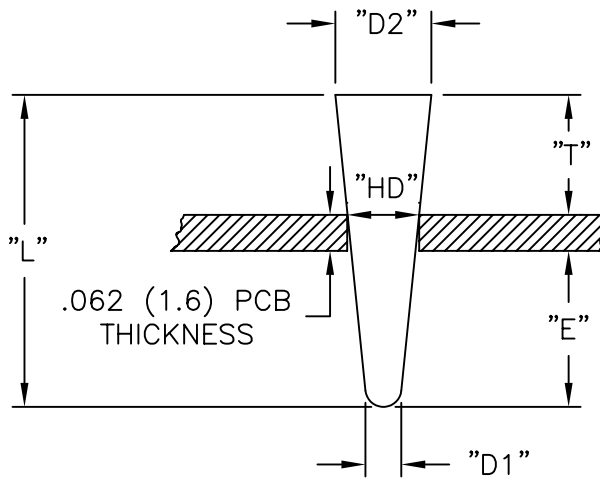

FIG. 1



FIG. 2



FIG. 3

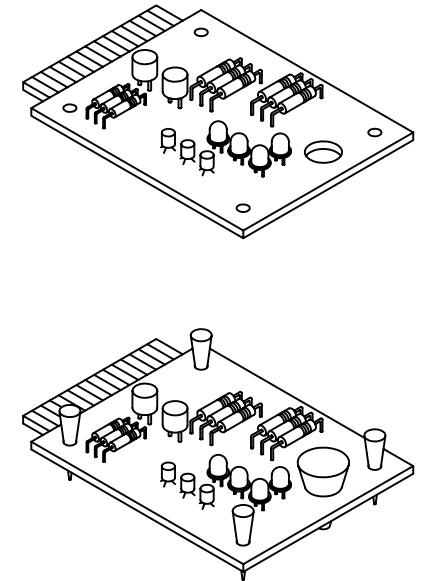
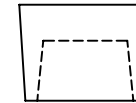

NOTES:

1. UL RATINGS DO NOT APPLY SINCE PARTS SHOULD NOT BE PERMANENTLY INSTALLED UN ASSEMBLY

TITLE: CIRCUIT BOARD HOLE PLUG				DWG IN IN (MM)		FINAL	
D	RMS-109 WAS RMS-122	SM 07.23.01	TOLERANCES UNLESS NOTED	FILE # CBHP	DWN: P.B.	APP:	PART #
C	ADDED RMS-122 & -123, CHANGED FILE #	SM 06.01.01	.XX=±.010	MAT'L: SEE TABLE	DT: 04-22-94	DT:	
B	DIMS. "D1" & "D2" REVERSED	PB 081794	.XXX=±.005	RE: RICHCO, INC	RICHCO INC.		SEE TABLE
A	PART NO. CBHP-XX WAS CBHP-XX-01; NOTE ADDED	PB 071994	FRAC=±1/64	PO BOX 804238, CHICAGO, 60680		PRINT TYPE	
REV	DESCRIPTION	ENGR DATE	ANG=±1°	(773) 539-4060		CA	