

RECOMMENDED HOLE LAYOUT FOR  
.070/(1.78) MAX. THICK P.C. BOARD.  
(FLANGE MOUNT)

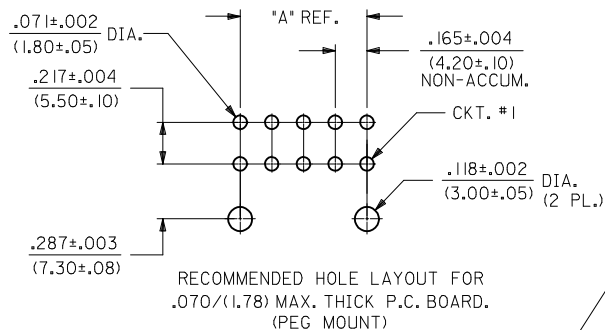

RECOMMENDED HOLE LAYOUT FOR  
.070/(1.78) MAX. THICK P.C. BOARD.  
(PEG MOUNT)

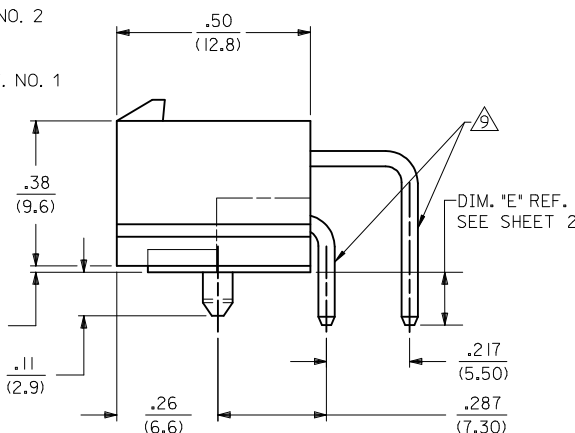
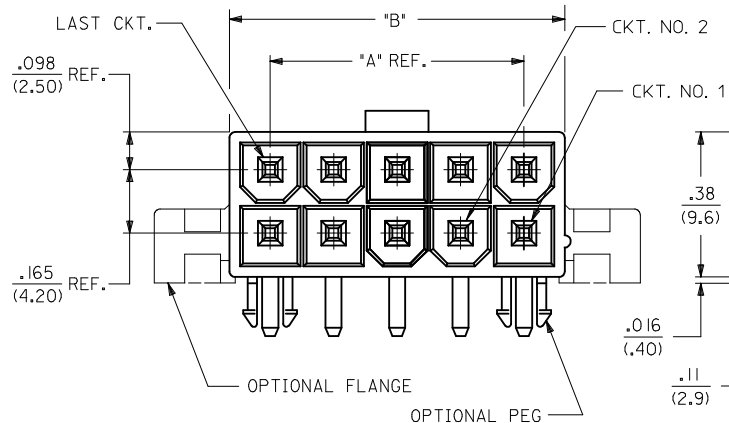
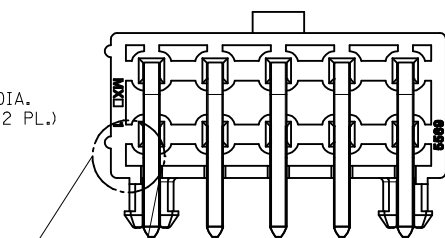

11  
4 PLACES  
APPLIES TO ALL CIRCUIT SIZES  
BOTH PEGGED AND FLANGED

**NOTES:**

- 1) HOUSING MATERIAL:  
"A" - NYLON 6/6, U.L. 94V-2, COLOR: NATURAL.  
"B" - NYLON 6/6, U.L. 94V-0, COLOR: NATURAL.
  - 2) TERMINAL MATERIAL: BRASS
  - 3) PART MATES WITH MINI-FIT JR. RECEPTACLE #5557.
  - 4) PACKAGING SPECIFICATION: BULK PACKED PER PK-5569-002  
TRAY PACKED PER PK-5569-003
  - 5) TERMINAL PLATING:  
"D" - .000030/(0.00076) MIN. SELECT GOLD AND .000100/(0.00254) MIN. SELECT MATTE TIN OVER .000050/(0.00127) MIN. NICKEL OVERALL.  
"E" - .000100/(0.00254) MIN. MATTE TIN OVER .000050/(0.00127) MIN. NICKEL OVERALL.
  - 6) MOUNTING OPTIONS:  
"1" - PEGS  
"2" - FLANGES
  - 7) THIS PART CONFORMS TO CLASS B REQUIREMENT OF COSMETIC SPECIFICATION PS-45499-002.
  - 8) PRODUCT SPECIFICATION: PS-5556-001.
  - 9) FORMING MARKS ARE ACCEPTABLE
  - 10) DISCOLORATION IN THE BANDOLIER CARRIER AREA OF THE PIN IS INHERENT TO THE PLATING PROCESS AND IS DUE TO THE MASKING EFFECT OF THE CARRIER. THIS DISCOLORATION IS IN A NON-FUNCTIONAL AREA OF THE PIN AND WILL NOT AFFECT THE PERFORMANCE OF THE HEADER ASSEMBLY.
- ▲ CORNER CORE-OUTS ARE OPTIONAL AND MAY OR MAY NOT BE PRESENT  
12) TEXT ON PART IS FOR REFERENCE ONLY. TEXT AND TEXT LOCATION MAY VARY DEPENDING ON PART NUMBER AND/OR TOOL.

CIRCUIT SIZE	DIM. "A"	DIM. "B"	DIM. "C"	DIM. "D"
2	N.A.	.213 (5.40)	.354 (9.00)	.606 (15.40)
4	.165 (4.20)	.378 (9.60)	.520 (13.20)	.772 (19.60)
6	.331 (8.40)	.543 (13.80)	.685 (17.40)	.937 (23.80)
8	.496 (12.60)	.709 (18.00)	.850 (21.60)	1.102 (28.00)
10	.661 (16.80)	.874 (22.20)	1.016 (25.80)	1.268 (32.20)
12	.827 (21.00)	1.039 (26.40)	1.181 (30.00)	1.433 (36.40)
14	.992 (25.20)	1.205 (30.60)	1.346 (34.20)	1.598 (40.60)
16	1.157 (29.40)	1.370 (34.80)	1.512 (38.40)	1.764 (44.80)
18	1.323 (33.60)	1.535 (39.00)	1.677 (42.60)	1.929 (49.00)
20	1.488 (37.80)	1.701 (43.20)	1.843 (46.80)	2.094 (53.20)
22	1.654 (42.00)	1.866 (47.40)	2.008 (51.00)	2.260 (57.40)
24	1.819 (46.20)	2.031 (51.60)	2.173 (55.20)	2.425 (61.60)

ADD BACK VIEW EC NO: UCP2017-0438 DRAWNCSLAFTER 2016/08/23 CHKD: APPR:FSMITH 2016/09/121 REV	QUALITY SYMBOLS ▽=0 ▽=0 ▽=0	GENERAL TOLERANCES (UNLESS SPECIFIED)		DIMENSION STYLE IN/MM		SCALE 4:1	DESIGN UNITS METRIC	THIRD ANGLE PROJECTION	
		4 PLACES ± ---	± ---	mm	INCH	DRAWN BY FRY	DATE 12/28/92	SELECTIVELY-LOADED RIGHT ANGLE HEADER ASSEMBLY. (MINI-FIT, JR. SERIES) <b>molex</b> DOCUMENT NO. SDA-43215-* SHEET NO. 1 OF 2	
3 PLACES ± ---	± .15			CHECKED BY FRY	DATE 12/28/92				
2 PLACES ± 0.38	± ---			APPROVED BY FSMITH	DATE 2012/02/02				
1 PLACE ± ---	± ---			MATERIAL NO.					
0 PLACE ±	±			ANGULAR ±1/2°					
		DRAFT WHERE APPLICABLE MUST REMAIN WITHIN DIMENSIONS		SIZE C		THIS DRAWING CONTAINS INFORMATION THAT IS PROPRIETARY TO MOLEX INCORPORATED AND SHOULD NOT BE USED WITHOUT WRITTEN PERMISSION			

ITEM NO.	CKT. SIZE	CHARACTERISTIC DESCRIPTION	HOUSING OPTION	PLATING	LETTER INDICATES PIN PLATING REQUIRED AT EACH CIRCUIT LOCATION. "-" = VOID CIRCUIT. SEE NOTE 5 ON SHEET 1.																								DIM	"E" REF.	PACKAGING
					1	2	3	4	5	6	7	8	9	10	11	12	13	14	15	16	17	18	19	20	21	22	23	24			
43215-0002	08	08A1E	PEGS	E	E	-	-	E	E	-	-	E	-	-	-	-	-	-	-	-	-	-	-	-	-	-	-	-	.13 (3.5)	BULK	
43215-0016	08	08B1E	PEGS	E	E	-	E	E	E	-	E	E	-	-	-	-	-	-	-	-	-	-	-	-	-	-	-	.13 (3.5)	TRAY		
43215-0017	14	14B2D	FLANGE	D	D	D	D	D	D	D	D	D	D	D	D	D	D	D	-	-	-	-	-	-	-	-	-	.43 (11.0)	BULK		
43215-0019	04	04B1E	PEGS	E	E	-	E	E	-	-	-	-	-	-	-	-	-	-	-	-	-	-	-	-	-	-	.13 (3.5)	TRAY			
43215-0020	06	06B1D	PEGS	D	D	-	D	-	D	-	-	-	-	-	-	-	-	-	-	-	-	-	-	-	-	-	.13 (3.5)	TRAY			
43215-0021	04	04B1D	PEGS	D	D	-	-	D	-	-	-	-	-	-	-	-	-	-	-	-	-	-	-	-	-	-	.13 (3.5)	TRAY			

CHARACTERISTICS LEGEND:

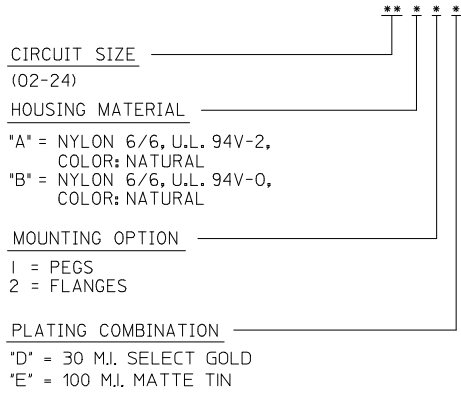

<b>SEE SHEET 1</b> EC NO: UCP2017-0438 DRWINGSLAFTER 2016/08/23 CHKD: F5 APPR:FSMITH 2016/09/21	QUALITY SYMBOLS	GENERAL TOLERANCES (UNLESS SPECIFIED)	DIMENSION STYLE	SCALE	DESIGN UNITS	THIRD ANGLE PROJECTION
	▽=0	mm INCH	IN/MM	1:1	METRIC	
	▽=0	4 PLACES ± --- ± ---	DRAWN BY DATE	TITLE		
	▽=0	3 PLACES ± --- ±.15	CHECKED BY DATE	SELECTIVELY-LOADED RIGHT ANGLE HEADER ASSEMBLY. (MINI-FIT, JR. SERIES)		
	▽=0	2 PLACES ± 0.38 ± ---	APPROVED BY DATE			
▽=0	1 PLACE ± --- ± ---	FSMITH 2012/02/02				
	0 PLACE ± ±	MATERIAL NO.	DOCUMENT NO.	SHEET NO.		
	ANGULAR ±1/2°	SEE CHART	SDA-43215-*	2 OF 2		
	DRAFT WHERE APPLICABLE MUST REMAIN WITHIN DIMENSIONS	THIS DRAWING CONTAINS INFORMATION THAT IS PROPRIETARY TO MOLEX INCORPORATED AND SHOULD NOT BE USED WITHOUT WRITTEN PERMISSION				

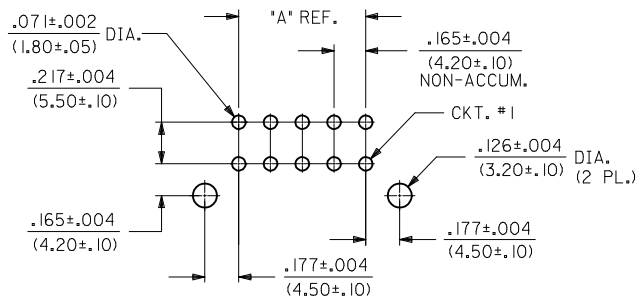
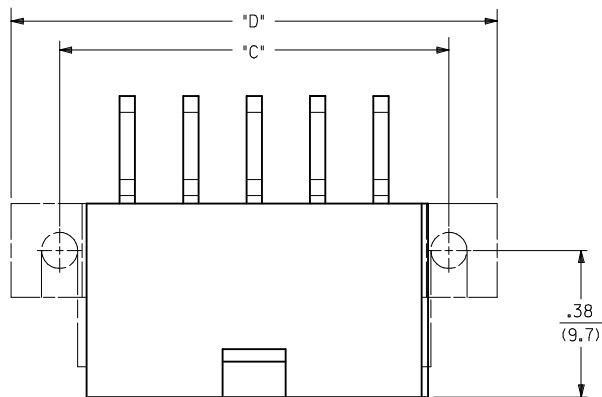

RECOMMENDED HOLE LAYOUT FOR  
.070/(1.78) MAX. THICK P.C. BOARD.  
(FLANGE MOUNT)

CIRCUIT SIZE	DIM. "A"	DIM. "B"	DIM. "C"	DIM. "D"
2	N.A.	.213 (5.40)	.354 (9.00)	.606 (15.40)
4	.165 (4.20)	.378 (9.60)	.520 (13.20)	.772 (19.60)
6	.331 (8.40)	.543 (13.80)	.685 (17.40)	.937 (23.80)
8	.496 (12.60)	.709 (18.00)	.850 (21.60)	1.102 (28.00)
10	.661 (16.80)	.874 (22.20)	1.016 (25.80)	1.268 (32.20)
12	.827 (21.00)	1.039 (26.40)	1.181 (30.00)	1.433 (36.40)
14	.992 (25.20)	1.205 (30.60)	1.346 (34.20)	1.598 (40.60)
16	1.157 (29.40)	1.370 (34.80)	1.512 (38.40)	1.764 (44.80)
18	1.323 (33.60)	1.535 (39.00)	1.677 (42.60)	1.929 (49.00)
20	1.488 (37.80)	1.701 (43.20)	1.843 (46.80)	2.094 (53.20)
22	1.654 (42.00)	1.866 (47.40)	2.008 (51.00)	2.260 (57.40)
24	1.819 (46.20)	2.031 (51.60)	2.173 (55.20)	2.425 (61.60)

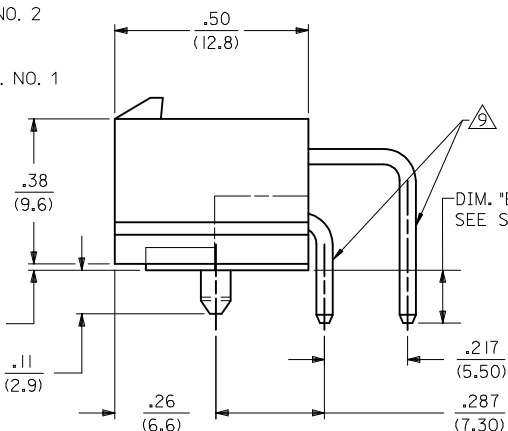
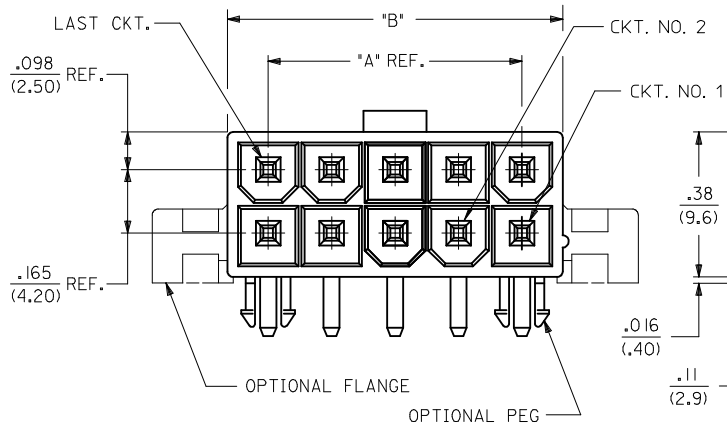

**NOTES:**

- HOUSING MATERIAL:  
"A" - NYLON 6/6, U.L. 94V-2, COLOR: NATURAL.  
"B" - NYLON 6/6, U.L. 94V-0, COLOR: NATURAL.
- TERMINAL MATERIAL: BRASS
- PART MATES WITH MINI-FIT JR. RECEPTACLE #5557.
- PACKAGING SPECIFICATION: BULK PACKED PER PK-5569-002  
TRAY PACKED PER PK-5569-003
- TERMINAL PLATING:  
"D" - .000030/(0.00076) MIN. SELECT GOLD AND .000100/(0.00254) MIN. SELECT MATTE TIN OVER .000050/(0.00127) MIN. NICKEL OVERALL.  
"E" - .000100/(0.00254) MIN. MATTE TIN OVER .000050/(0.00127) MIN. NICKEL OVERALL.
- MOUNTING OPTIONS:  
"1" - PEGS  
"2" - FLANGES
- THIS PART CONFORMS TO CLASS B REQUIREMENT OF COSMETIC SPECIFICATION PS-45499-002.
- PRODUCT SPECIFICATION: PS-5556-001.

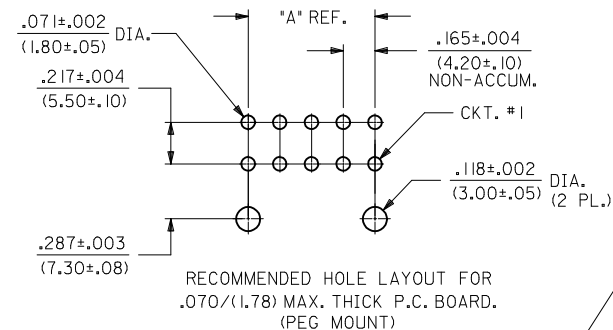

RECOMMENDED HOLE LAYOUT FOR  
.070/(1.78) MAX. THICK P.C. BOARD.  
(PEG MOUNT)

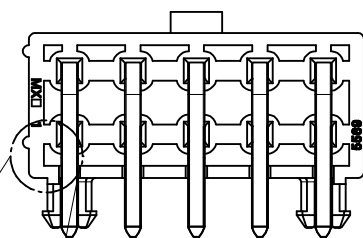

11  
4 PLACES  
APPLIES TO ALL CIRCUIT SIZES  
BOTH PEGGED AND FLANGED

ADD BACK VIEW EC NO: UCP2017-0438 DRAWNCSLAFTER 2016/08/23 CHKD: APPR:FSMITH 2016/09/121	QUALITY SYMBOLS ▽=0 ▽=0 ▽=0	GENERAL TOLERANCES (UNLESS SPECIFIED)		DIMENSION STYLE IN/MM		SCALE 4:1	DESIGN UNITS METRIC	THIRD ANGLE PROJECTION	
		4 PLACES ± ---	± ---	mm	INCH	DRAWN BY FRY	DATE 12/28/92	SELECTIVELY-LOADED RIGHT ANGLE HEADER ASSEMBLY. (MINI-FIT, JR. SERIES)	
3 PLACES ± ---	± .15			CHECKED BY FRY	DATE 12/28/92	molex			
2 PLACES ± 0.38	± ---			APPROVED BY FSMITH	DATE 2012/02/02				DOCUMENT NO. SDA-43215-*
1 PLACE ± ---	± ---					SHEET NO. 1 OF 2			
0 PLACE ±	±								THIS DRAWING CONTAINS INFORMATION THAT IS PROPRIETARY TO MOLEX INCORPORATED AND SHOULD NOT BE USED WITHOUT WRITTEN PERMISSION
		ANGULAR ±1/2°		MATERIAL NO. SEE SHEET 2					
		DRAFT WHERE APPLICABLE MUST REMAIN WITHIN DIMENSIONS		SIZE C					

ITEM NO.	CKT. SIZE	CHARACTERISTIC DESCRIPTION	HOUSING OPTION	PLATING	LETTER INDICATES PIN PLATING REQUIRED AT EACH CIRCUIT LOCATION. "-" = VOID CIRCUIT. SEE NOTE 5 ON SHEET 1.																								DIM	"E" REF.	PACKAGING
					1	2	3	4	5	6	7	8	9	10	11	12	13	14	15	16	17	18	19	20	21	22	23	24			
43215-0002	08	08A1E	PEGS	E	E	-	-	E	E	-	-	E	-	-	-	-	-	-	-	-	-	-	-	-	-	-	-	-	.13 (3.5)	BULK	
43215-0016	08	08B1E	PEGS	E	E	-	E	E	E	-	E	E	-	-	-	-	-	-	-	-	-	-	-	-	-	-	-	.13 (3.5)	TRAY		
43215-0017	14	14B2D	FLANGE	D	D	D	D	D	D	D	D	D	D	D	D	D	D	D	-	-	-	-	-	-	-	-	-	.43 (11.0)	BULK		
43215-0019	04	04B1E	PEGS	E	E	-	E	E	-	-	-	-	-	-	-	-	-	-	-	-	-	-	-	-	-	-	-	.13 (3.5)	TRAY		
43215-0020	06	06B1D	PEGS	D	D	-	D	-	D	-	-	-	-	-	-	-	-	-	-	-	-	-	-	-	-	-	-	.13 (3.5)	TRAY		
43215-0021	04	04B1D	PEGS	D	D	-	-	D	-	-	-	-	-	-	-	-	-	-	-	-	-	-	-	-	-	-	-	.13 (3.5)	TRAY		

CHARACTERISTICS LEGEND:

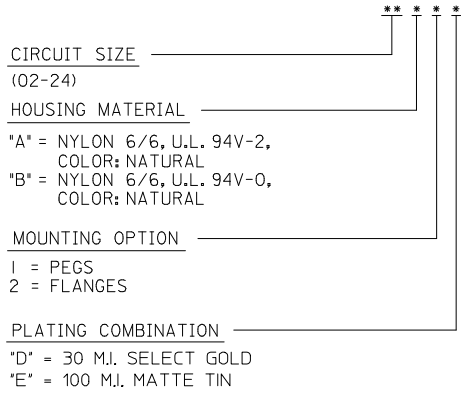

<b>SEE SHEET 1</b> EC NO: UCP2017-0438 DRW:CLAFTR 2016/08/23 CHKD: F5 APPR:FSMITH 2016/09/21	QUALITY SYMBOLS	GENERAL TOLERANCES (UNLESS SPECIFIED)	DIMENSION STYLE	SCALE	DESIGN UNITS	THIRD ANGLE PROJECTION
	▽=0	mm INCH	IN/MM	1:1	METRIC	☉
	▽=0	4 PLACES ± --- ± ---	DRAWN BY DATE	TITLE		
	▽=0	3 PLACES ± --- ± .15	CHECKED BY DATE	SELECTIVELY-LOADED RIGHT ANGLE HEADER ASSEMBLY. (MINI-FIT, JR. SERIES)		
	▽=0	2 PLACES ± 0.38 ± ---	APPROVED BY DATE			
	1 PLACE ± --- ± ---	MATERIAL NO.	DATE	DOCUMENT NO.	SHEET NO.	
	0 PLACE ± ±	SEE CHART	2012/02/02	SDA-43215-*	2 OF 2	
	ANGULAR ±1/2°	DRAFT WHERE APPLICABLE MUST REMAIN WITHIN DIMENSIONS				
		THIS DRAWING CONTAINS INFORMATION THAT IS PROPRIETARY TO MOLEX INCORPORATED AND SHOULD NOT BE USED WITHOUT WRITTEN PERMISSION				