

THIS DRAWING IS UNPUBLISHED. RELEASED FOR PUBLICATION  
 © COPYRIGHT BY TYCO ELECTRONICS CORPORATION. ALL RIGHTS RESERVED.

LOC		DIST		REVISIONS			
P	LTR	DESCRIPTION		DATE	DWN	APVD	
X0	DF	A	RELEASED	4-18-05	CT	BM	

- 1 STAINLESS STEEL PER ASTM-A-582
- 2 PASSIVATION PER AMS QQ-P-35
- 3. SMP INTERFACE PER MIL-STD-348A, FIGURE 326-4
- 4. DSCC REFERENCE PART NUMBER: 94007ZSP-6SC

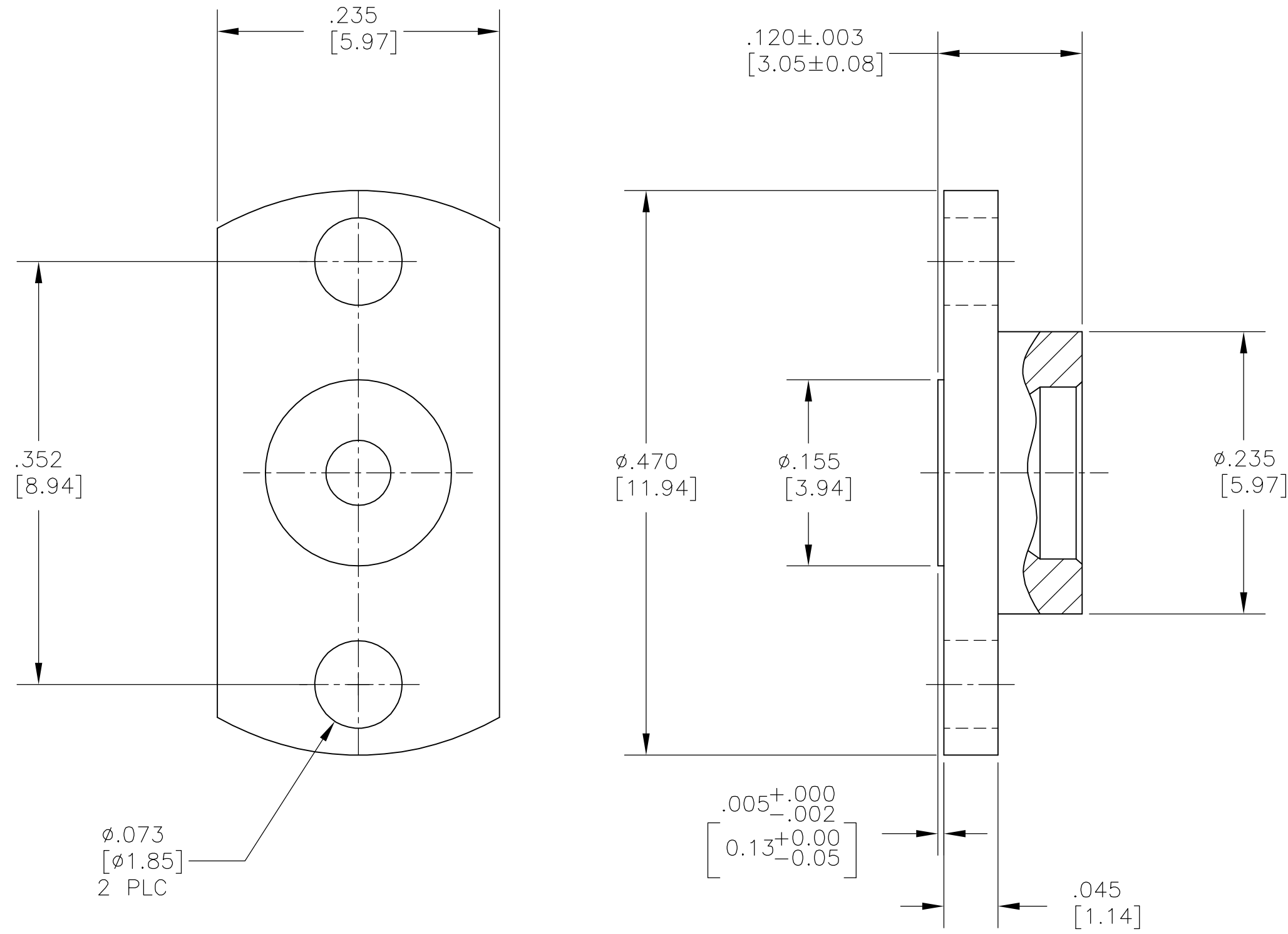

		1757030-1
FINISH	MATERIAL	PART NO.

THIS DRAWING IS A CONTROLLED DOCUMENT.		DWN B. MOYER	13APROS	Tyco Electronics Corporation Harrisburg, Pa 17105-3608											
DIMENSIONS: INCHES		CHK C.C.THOMAS	4-18-05												
TOLERANCES UNLESS OTHERWISE SPECIFIED:		APVD B. MOYER	4-18-05												
<table border="1"> <tr><td>0 PLC</td><td>± -</td></tr> <tr><td>1 PLC</td><td>± -</td></tr> <tr><td>2 PLC</td><td>± -</td></tr> <tr><td>3 PLC</td><td>± .005 (0.13)</td></tr> <tr><td>4 PLC</td><td>± -</td></tr> <tr><td>ANGLES</td><td>± 1'</td></tr> </table>		0 PLC	± -		1 PLC	± -	2 PLC	± -	3 PLC	± .005 (0.13)	4 PLC	± -	ANGLES	± 1'	PRODUCT SPEC
0 PLC	± -														
1 PLC	± -														
2 PLC	± -														
3 PLC	± .005 (0.13)														
4 PLC	± -														
ANGLES	± 1'														
MATERIAL SEE TABLE	FINISH SEE TABLE	APPLICATION SPEC	SIZE A2	CAGE CODE 00779	DRAWING NO. C=1757030	RESTRICTED TO									
CUSTOMER DRAWING		WEIGHT	SCALE 10:1	SHEET 1	OF 1	REV A									