

# 1.5A Low Dropout Voltage Regulator

## FEATURES

- Guaranteed 1.5A Output Current
- Three Terminal Adjustable or Fixed 2.5V, 3.3V and 5.0V
- Low Quiescent Current
- Low Dropout Voltage of 1.1V @ 1.5A
- 0.1% Line and 0.1% Load Regulation
- Stable with 10uF Ceramic Capacitor
- Overcurrent and Thermal Protection
- Available Packages: TO-252, TO-220, and TO-263
- Similar to Industry Standard LT1086/LT1586

## APPLICATIONS

- Desktop PCs, Servers
- Powering VGA and Sound Cards
- Cordless Phones
- Battery Chargers
- Adjustable Power Supplies
- Portable Instrumentation
- SMPS Post-Regulator
- Constant Current Regulators
- Disk Drives

Refer to Page 5 for Pinouts

Now Available in Lead Free Packaging

## DESCRIPTION

The SPX2815 is a low power positive-voltage regulator designed to satisfy moderate power requirements with a cost effective, small footprint solution. This device is an excellent choice for use in battery-powered applications and portable computers. The SPX2815 features very low quiescent current and a low dropout voltage of 1.1V at a full load. As output current decreases, quiescent current flows into the load, increasing efficiency. SPX2815 is available in adjustable or fixed 2.5V, 3.3V and 5.0V output voltages.

The SPX2815 is offered in several 3-pin surface mount packages: TO-252, TO-220 and TO-263. An output capacitor of 10 $\mu$ F ceramic or tantalum provides unconditional stability.

## FUNCTIONAL DIAGRAM (Adjustable)

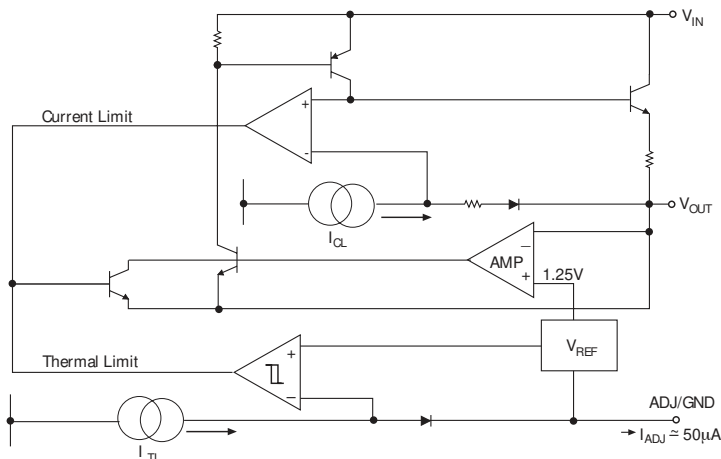

## ABSOLUTE MAXIMUM RATINGS

Power Dissipation.....Internally Limited  
 Lead Temperature (soldering, 5 seconds) .....260°C  
 Storage Temperature Range.....-65°C to +150°C

Operating Junction Temperature Range.....-40°C to +125°C  
 Input Supply Voltage ..... +10V  
 Input to Output Voltage ..... +8.8V  
 ESD Rating ..... 2kV min

## ELECTRICAL CHARACTERISTICS

at  $V_{IN}=V_{OUT} + 1.5V$ ,  $T_A = 25^\circ C$ ,  $C_{IN} = C_{OUT} = 10\mu F$ ,  $I_{OUT}=10mA$ , unless otherwise specified. The **Boldface** applies over the full operating temperature range.

PARAMETER	MIN	TYP	MAX	MIN	TYP	MAX	UNITS	CONDITIONS
<b>2.5V Version</b>	<b>SPX2815A</b>			<b>SPX2815</b>				
Output Voltage	2.475 <b>2.450</b>	2.500	2.525 <b>2.550</b>	2.450 <b>2.425</b>	2.500	2.550 <b>2.575</b>	V	$I_{OUT} = 10mA$ , $V_{IN} = 4.5V$ $10mA \leq I_{OUT} \leq 1.5A$ , $4.25V \leq V_{IN} \leq 10V$
<b>3.30V Version</b>								
Output Voltage	3.267 <b>3.234</b>	3.300	3.333 <b>3.366</b>	3.234 <b>3.201</b>	3.300	3.366 <b>3.399</b>	V	$I_{OUT} = 10mA$ , $V_{IN} = 5V$ $10mA \leq I_{OUT} \leq 1.5A$ , $4.75V \leq V_{IN} \leq 10V$
<b>5.0V Version</b>								
Output Voltage	4.950 <b>4.900</b>	5.000	5.050 <b>5.100</b>	4.900 <b>4.850</b>	5.000	5.100 <b>5.150</b>	V	$I_{OUT}=10mA$ , $V_{IN}=7V$ $10mA \leq I_{OUT} \leq 1.5A$ , $6.50V \leq V_{IN} \leq 10V$
<b>All Voltage Options</b>								
Reference Voltage	1.238 <b>1.225</b>	1.250	1.262 <b>1.275</b>	1.225 <b>1.212</b>	1.250	1.275 <b>1.287</b>	V	$I_{OUT}=10mA$ , $(V_{IN} - V_{OUT})= 2V$ $10mA \leq I_{OUT} \leq 1.5A$ , $1.5V \leq (V_{IN} - V_{OUT}) \leq 10V$
Output Voltage Temperature Stability		0.3			0.5		%	
Line Regulation		0.1 0.1 0.1	0.2 0.2 0.2		0.1 0.1 0.1	0.2 0.2 0.2	%	$4.25V \leq V_{IN} \leq 10V$ , $V_{OUT}=2.5V$ , $I_{OUT}=10mA$ $4.75V \leq V_{IN} \leq 10V$ , $V_{OUT}=3.3V$ , $I_{OUT}=10mA$ $6.50V \leq V_{IN} \leq 10V$ , $V_{OUT}=5.0V$ , $I_{OUT}=10mA$
Load Regulation		0.1 0.1 0.1	0.3 0.3 0.3		0.1 0.1 0.1	0.3 0.3 0.3	%	$10mA \leq I_{OUT} \leq 1.5A$ , $V_{OUT}=2.5V$ $10mA \leq I_{OUT} \leq 1.5A$ , $V_{OUT}=3.3V$ $10mA \leq I_{OUT} \leq 1.5A$ , $V_{OUT}=5.0V$
Dropout Voltage (Note 2)		1.00 1.10	1.2		1.00 1.10	1.2	V	$I_{OUT}=0.5A$ $I_{OUT}=1.5A$
Quiescent Current		4	10		4	10	mA	Fixed voltage versions
Adjust Pin Current		50	<b>120</b>		50	<b>120</b>	$\mu A$	
Current Limit	2.5			2.5			A	$(V_{IN} - V_{OUT})=5V$
Thermal Regulation		0.01	0.1		0.01	0.1	%/W	25°C, 30mS pulse
Ripple Rejection	60	75		60	75		dB	$f_{RIPPLE}=120Hz$ , $(V_{IN} - V_{OUT})=2V$ , $V_{RIPPLE}=1V_{PP}$
Long Term Stability		0.03			0.03		%	125°C, 1000Hrs
RMS Output Noise		0.003			0.003		%	% of $V_{OUT}$ , 10Hz $\leq f \leq$ 10kHz
Thermal Resistance		3 29.3 3 31.4 6 50			3 29.3 3 31.4 6 50		$^\circ C/W$	TO-220 Junction to Case, at Tab TO-220 Junction to Ambient TO-263 Junction to Case, at Tab TO-263 Junction to Ambient TO-252 Junction to Case, at Tab TO-252 Junction to Ambient

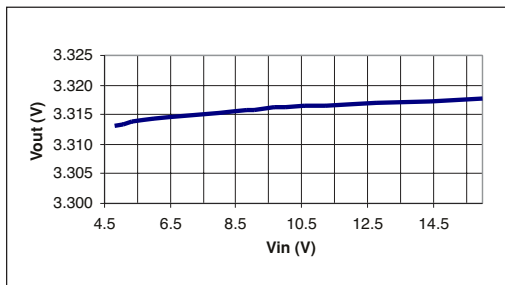

Figure 1. Line Regulation for SPX2815U-3.3;  $I_{OUT}=10mA$

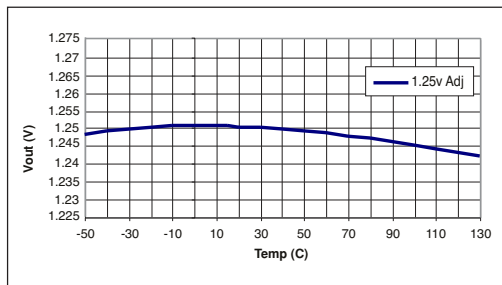

Figure 2.  $V_{OUT}$  vs Temperature,  $V_{IN}=2.5V$ ,  $I_{OUT}=10mA$

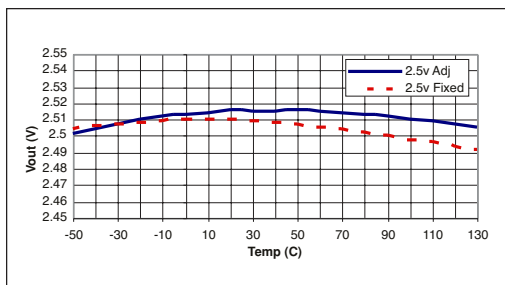

Figure 3.  $V_{IN}=4.0V$ ,  $I_{OUT}=10mA$

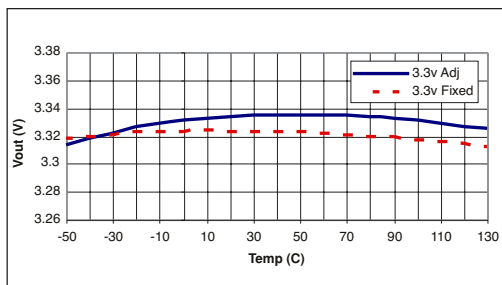

Figure 4.  $V_{IN}=5.0V$ ,  $I_{OUT}=10mA$

## APPLICATION INFORMATION

### Output Capacitor

To ensure the stability of the SPX2815, an output capacitor of at least  $10\mu F$  (ceramic or tantalum) or  $22\mu F$  (aluminum) is required. The value may change based on the application requirements of the output load or temperature range. The value of Equivalent Series Resistance (ESR) can vary based on the type of capacitor used in the applications to guarantee stability. The recommended value for ESR is  $0.5\Omega$  or less. A larger value of output capacitance (up to  $100\mu F$ ) can improve the load transient response.

### Soldering Methods

The SPX2815 die is attached to the heatsink lead which exits opposite the input, output, and ground pins.

### Thermal Characteristics

The SPX2815 features internal thermal limiting to protect the device during overload condi-

tions. Special care needs to be taken during continuous load conditions such that the maximum junction temperature does not exceed  $125^{\circ}C$ . Thermal protection is activated at  $>179^{\circ}C$  and deactivated at  $<165^{\circ}C$ .

The thermal interaction from other components in the application can affect the thermal resistance of the SPX2815. The actual thermal resistance can be determined with experimentation.

SPX2815 power dissipation is calculated as follows:

$$P_D = (V_{IN} - V_{OUT})(I_{OUT})$$

Maximum Junction Temperature range:

$$T_J = T_A(\max) + P_D * \theta_{JA} \text{ (thermal resistance, junction-to-ambient)}$$

Maximum junction temperature must not exceed  $125^{\circ}C$ .

**Ripple Rejection**

Ripple rejection can be improved by adding a capacitor between the ADJ pin and ground as shown in Figure 8. When ADJ pin bypassing is used, the value of the output capacitor required increases to its maximum. If the ADJ pin is not bypassed, the value of the output capacitor can be lowered to 22µF for an electrolytic aluminum capacitor or 10µF for a solid tantalum capacitor (Fig 7). However, the value of the ADJ-bypass capacitor should be chosen with respect to the following equation:

$$C = \frac{1}{(6.28 * F_R * R_1)}$$

Where

- C = value of the capacitor in Farads (select an equal or larger standard value),
- F<sub>R</sub> = ripple frequency in Hz,
- R<sub>1</sub> = value of resistor R1 in Ohms.

If an ADJ-bypass capacitor is used, the amplitude of the output ripple will be independent of the output voltage. If an ADJ-bypass capacitor is not used, the output ripple will be proportional to the ratio of the output voltage to the reference voltage:

$$M = V_{OUT} / V_{REF}$$

Where M = multiplier for the ripple seen when the ADJ pin is optimally bypassed.

$$V_{REF} = 1.25V$$

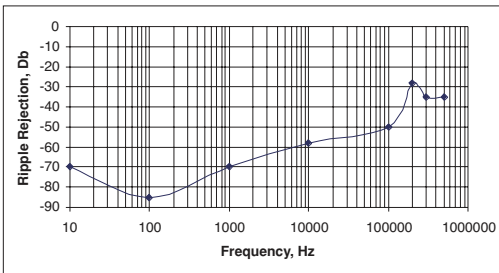

Figure 5. Ripple Rejection; Vin=3.3V, Vout=1.8V (adj.), Iload=200mA

Ripple rejection for the adjustable version is shown in Figure 5.

**Output Voltage**

The output of the adjustable regulator can be set to any voltage between 1.25V and 15V. The value of V<sub>OUT</sub> can be quickly approximated using the formula

$$V_{OUT} = 1.25 * (R_1 + R_2) / R_1$$

A small correction to this formula is required depending on the values of resistors R<sub>1</sub> and R<sub>2</sub>, since the adjustable pin current (approx 50µA) flows through R<sub>2</sub>. When I<sub>ADJ</sub> is taken into account, the formula becomes

$$V_{OUT} = V_{REF} * (1 + (R_2 / R_1)) + I_{ADJ} * R_2$$

where

$$V_{REF} = 1.25V$$

**Layout Considerations**

Parasitic line resistance can degrade load regulation. In order to avoid this, connect R<sub>1</sub> directly to V<sub>OUT</sub> as illustrated in Figure 13. For the same reason, R<sub>2</sub> should be connected to the negative side of the load.

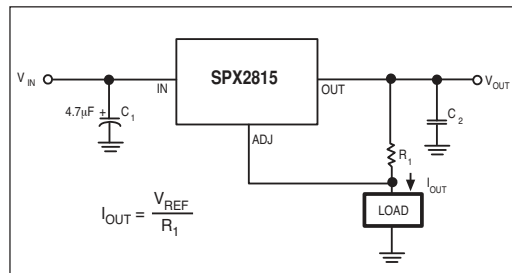

Figure 6. Current Source

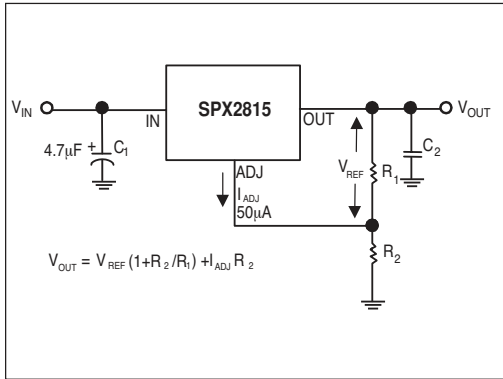

Figure 7. Typical Adjustable Regulator

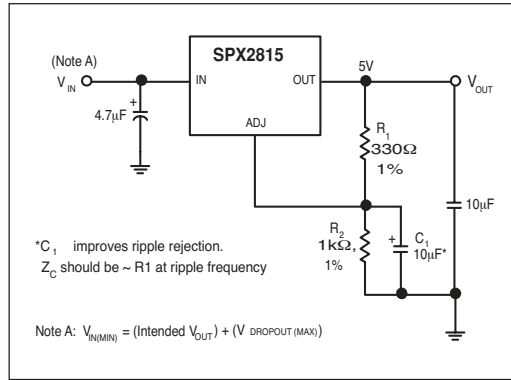

Figure 8. Improving Ripple Rejection

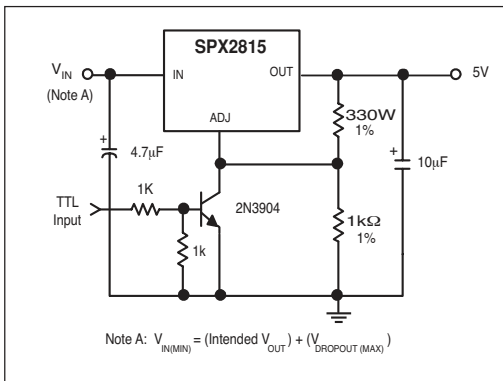

Figure 9. 5V Regulator with Shutdown

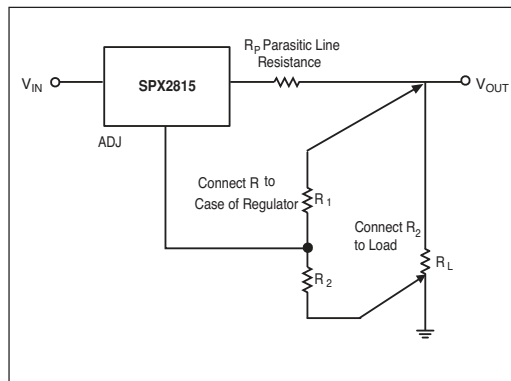
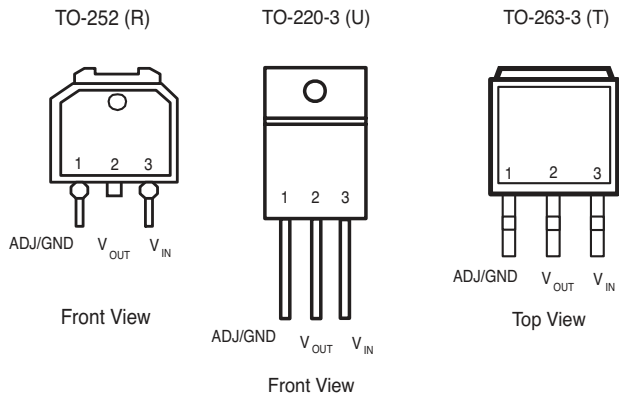
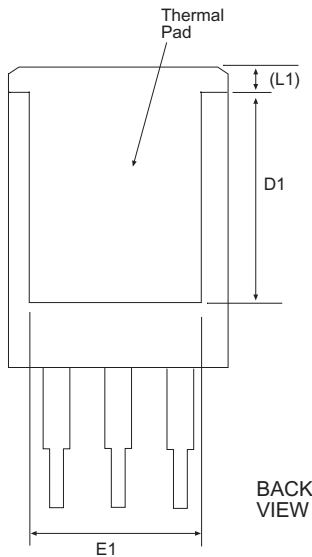
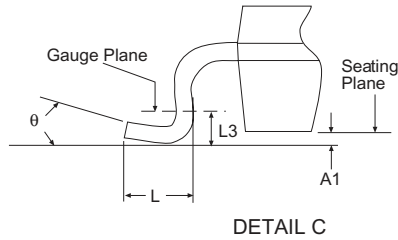
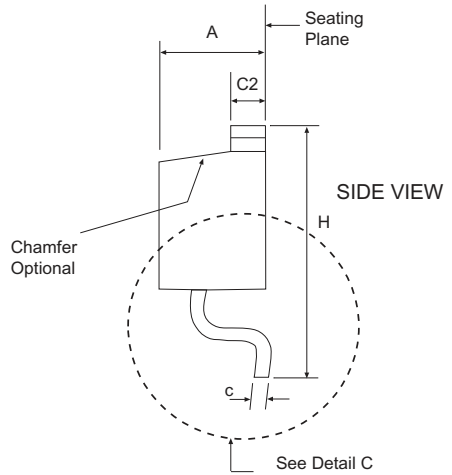
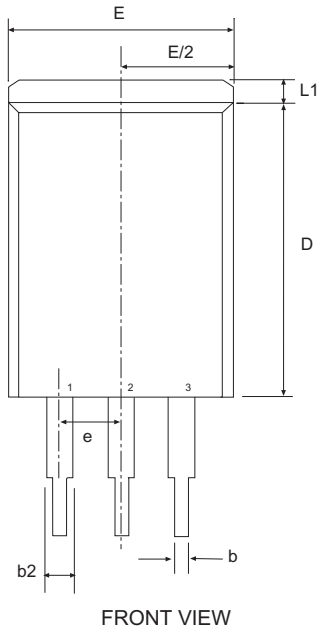

Figure 10. Recommended Connections for Best Results

PINOUTS



Note: Tab is connected to Pin 2 (Vout)



SYMBOL	Inches Controlling Dimension			Millimeters Conversion Factor: 1 Inch = 25.40 mm		
	MIN	NOM	MAX	MIN	NOM	MAX
A	0.160	-	0.190	4.06	-	4.83
A1	0.000	-	0.010	0.00	-	0.25
b	0.020	-	0.039	0.51	-	0.99
b2	0.045	-	0.070	1.14	-	1.78
c	0.015	-	0.029	0.38	-	0.74
c2	0.045	-	0.065	1.14	-	1.65
D	0.330	-	0.380	8.38	-	9.65
D1	0.270	-	-	6.86	-	-
E	0.380	-	0.420	9.65	-	10.67
E1	0.245	-	-	6.22	-	-
e	.100 BSC			2.54 BSC		
H	0.575	-	0.625	14.61	-	15.88
L	0.070	-	0.110	1.78	-	2.79
L1	-	-	0.066	-	-	1.68
L3	.010 BSC			0.25 BSC		
Ø	0°	-	8°	0°	-	8°
SIPEX Pkg Signoff Date/Rev:				JL Aug5-05 / Rev A		

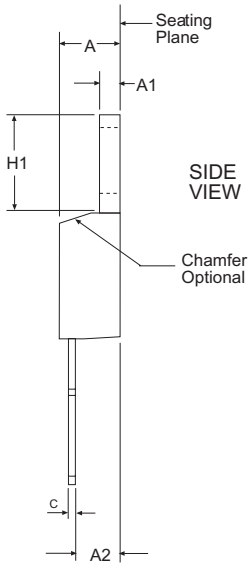
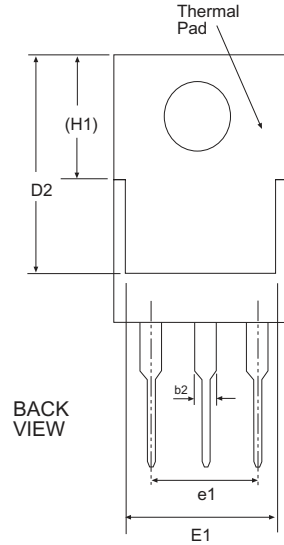
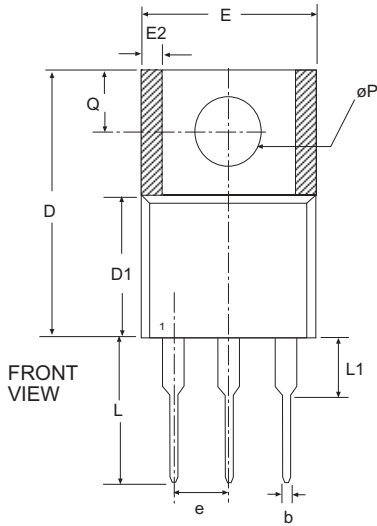

3 Pin TO-220		JEDEC TO-220			Variation AB		
SYMBOL	Dimensions in Inches: Controlling Dimension			Dimensions in Millimeters: Conversion Factor: 1 Inch = 25.40 mm			
	MIN	NOM	MAX	MIN	NOM	MAX	
A	0.140	-	0.190	3.56	-	4.83	
A1	0.020	-	0.055	0.51	-	1.27	
A2	0.080	-	0.115	2.03	-	2.79	
b	0.015	0.027	0.040	0.25	0.51	1.02	
b2	0.045	0.057	0.070	1.14	1.45	1.78	
c	0.014	-	0.024	0.25	-	0.51	
D	0.560	-	0.650	14.22	-	16.51	
D1	0.330	-	0.355	8.38	-	8.89	
D2	0.480	-	0.507	12.19	-	12.70	
E	0.380	-	0.420	9.65	-	10.67	
E1	0.270	-	0.350	6.86	-	8.89	
E2	-	-	0.030	-	-	0.76	
e	.100 BSC			2.54 BSC			
e1	.200 BSC			5.08 BSC			
H1	0.230	-	0.270	5.84	-	6.86	
L	0.500	-	0.580	12.70	-	14.73	
L1	-	-	0.250	-	-	6.35	
øP	0.139	-	0.161	3.30	-	4.06	
Q	0.100	-	0.135	2.54	-	3.30	
SIPEX Pkg Signoff Date/Rev:				JL Aug4-05 / Rev A			

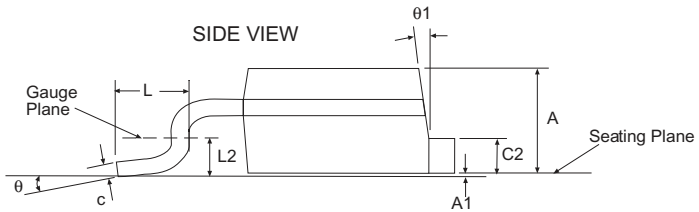
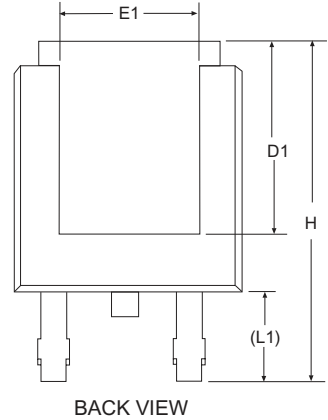
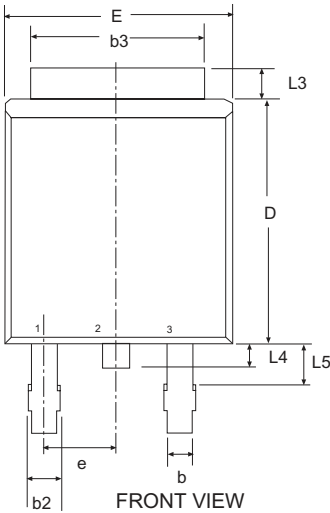

3 Pin TO-252		JEDEC TO-252		Variation AA		
SYMBOL	Dimensions in Inches: Controlling Dimension			Dimensions in Millimeters Conversion Factor: 1 Inch = 25.40 mm		
	MIN	NOM	MAX	MIN	NOM	MAX
A	0.086	-	0.094	2.18	-	2.39
A1	-	-	0.005	-	-	0.13
b	0.025	-	0.035	0.64	-	0.89
b2	0.030	-	0.045	0.76	-	1.14
b3	0.195	-	0.215	4.95	-	5.46
c	0.018	-	0.024	0.46	-	0.61
c2	0.018	-	0.035	0.46	-	0.89
D	0.235	0.240	0.245	5.97	6.10	6.22
D1	0.205	-	-	5.21	-	-
E	0.250	-	0.265	6.35	-	6.73
E1	0.170	-	-	4.32	-	-
e	.090 BSC			2.29 BSC		
H	0.370	-	0.410	9.4	-	10.41
L	0.055	0.060	0.070	1.4	1.52	1.78
L1	.108 REF			2.74 REF		
L2	.020 BSC			0.51 BSC		
L3	0.035	-	0.050	0.89	-	1.27
L4	-	-	0.040	-	-	1.02
L5	0.045	-	0.060	1.14	-	1.52
ø	0°	-	10°	0°	-	10°
ø1	0°	-	15°	0°	-	15°
SIPEX Pkg Signoff Date/Rev:				JL Aug4-05/Rev A		



## ORDERING INFORMATION

PART NUMBERS	ACC.	TOP MARK	OUTPUT VOLTAGE	PACKAGE
SPX2815AR .....	1%	SPX2815ARYYYWW.....	Adj.....	3 lead TO-252
SPX2815AR/TR .....	1%	SPX2815ARYYYWW.....	Adj.....	3 lead TO-252
SPX2815AR-2-5 .....	1%	SPX2815AR25YYWW.....	2.5V .....	3 lead TO-252
SPX2815AR-2-5/TR .....	1%	SPX2815AR25YYWW.....	2.5V .....	3 lead TO-252
SPX2815AR-3-3 .....	1%	SPX2815AR33YYWW.....	3.3V .....	3 lead TO-252
SPX2815AR-3-3/TR .....	1%	SPX2815AR33YYWW.....	3.3V .....	3 lead TO-252
SPX2815AR-5-0 .....	1%	SPX2815AR50YYWW.....	5.0V .....	3 lead TO-252
SPX2815AR-5-0/TR .....	1%	SPX2815AR50YYWW.....	5.0V .....	3 lead TO-252
SPX2815AT .....	1%	SPX2815ATYYWW.....	Adj.....	3 lead TO-263
SPX2815AT/TR .....	1%	SPX2815ATYYWW.....	Adj.....	3 lead TO-263
SPX2815AT-2-5 .....	1%	SPX2815AT25YYWW.....	2.5V .....	3 lead TO-263
SPX2815AT-2-5/TR .....	1%	SPX2815AT25YYWW.....	2.5V .....	3 lead TO-263
SPX2815AT-3-3 .....	1%	SPX2815AT33YYWW.....	3.3V .....	3 lead TO-263
SPX2815AT-3-3/TR .....	1%	SPX2815AT33YYWW.....	3.3V .....	3 lead TO-263
SPX2815AT-5-0 .....	1%	SPX2815AT50YYWW.....	5.0V .....	3 lead TO-263
SPX2815AT-5-0/TR .....	1%	SPX2815AT50YYWW.....	5.0V .....	3 lead TO-263
SPX2815AU .....	1%	SPX2815AUYYWW.....	Adj.....	3 lead TO-220
SPX2815AU-2-5 .....	1%	SPX2815AU25YYWW.....	2.5V .....	3 lead TO-220
SPX2815AU-3-3 .....	1%	SPX2815AU33YYWW.....	3.3V .....	3 lead TO-220
SPX2815AU-5-0 .....	1%	SPX2815AU50YYWW.....	5.0V .....	3 lead TO-220

Available in lead free packaging. To order add “-L” suffix to part number.

Example: SPX2815AU-5-0 = standard; SPX2815AU-L -5-0/TR = lead free.

Pack quantity is 500 for TO-263 and 2,000 for TO-252.

/TR = Tape and Reel



Solved By Sipex™

Sipex Corporation

Headquarters and  
Sales Office

233 South Hillview Drive  
Milpitas, CA 95035  
TEL: (408) 934-7500  
FAX: (408) 935-7600

Sipex Corporation reserves the right to make changes to any products described herein. Sipex does not assume any liability arising out of the application or use of any product or circuit described herein; neither does it convey any license under its patent rights nor the rights of others.

SPX2815R .....	2%	.....	SPX2815RYYWW.....Adj .....	3 lead TO-252
SPX2815R/TR .....	2%	.....	SPX2815RYYWW.....Adj .....	3 lead TO-252
SPX2815R-2-5 .....	2%	.....	SPX2815R25YYWW.....2.5V .....	3 lead TO-252
SPX2815R-2-5/TR .....	2%	.....	SPX2815R25YYWW.....2.5V .....	3 lead TO-252
SPX2815R-3-3 .....	2%	.....	SPX2815R33YYWW.....3.3V .....	3 lead TO-252
SPX2815R-3-3/TR .....	2%	.....	SPX2815R33YYWW.....3.3V .....	3 lead TO-252
SPX2815R-5-0 .....	2%	.....	SPX2815R50YYWW.....5.0V .....	3 lead TO-252
SPX2815R-5-0/TR .....	2%	.....	SPX2815R50YYWW.....5.0V .....	3 lead TO-252
SPX2815T .....	2%	.....	SPX2815TYYWW.....Adj .....	3 lead TO-263
SPX2815T/TR .....	2%	.....	SPX2815TYYWW.....Adj .....	3 lead TO-263
SPX2815T-2-5 .....	2%	.....	SPX2815T25YYWW.....2.5V .....	3 lead TO-263
SPX2815T-2-5/TR .....	2%	.....	SPX2815T25YYWW.....2.5V .....	3 lead TO-263
SPX2815T-3-3 .....	2%	.....	SPX2815T33YYWW.....3.3V .....	3 lead TO-263
SPX2815T-3-3/TR .....	2%	.....	SPX2815T33YYWW.....3.3V .....	3 lead TO-263
SPX2815T-5-0 .....	2%	.....	SPX2815T50YYWW.....5.0V .....	3 lead TO-263
SPX2815T-5-0/TR .....	2%	.....	SPX2815T50YYWW.....5.0V .....	3 lead TO-263
SPX2815U .....	2%	.....	SPX2815UYYYWW.....Adj .....	3 lead TO-220
SPX2815U-2-5 .....	2%	.....	SPX2815U25YYWW.....2.5V .....	3 lead TO-220
SPX2815U-3-3 .....	2%	.....	SPX2815U33YYWW.....3.3V .....	3 lead TO-220
SPX2815U-5-0 .....	2%	.....	SPX2815U50YYWW.....5.0V .....	3 lead TO-220

**Available in lead free packaging. To order add “-L” suffix to part number.**

**Example: SPX2815U-5-0 = standard; SPX2815U-L -5-0/TR = lead free.**

Pack quantity is 500 for TO-263 and 2,000 for TO-252.

/TR = Tape and Reel



**Sipex Corporation**

**Headquarters and  
Sales Office**  
233 South Hillview Drive  
Milpitas, CA 95035  
TEL: (408) 934-7500  
FAX: (408) 935-7600

Sipex Corporation reserves the right to make changes to any products described herein. Sipex does not assume any liability arising out of the application or use of any product or circuit described herein; neither does it convey any license under its patent rights nor the rights of others.