

PRODUCT DATA DRAWING

REVISION HISTORY			
REV	DESCRIPTION	DATE	APPROVED
-	DCN 38515	09/11	STW
A	REV. DCN 39575	12/13/12	DAL
B	DCN 42425	06/16	STW

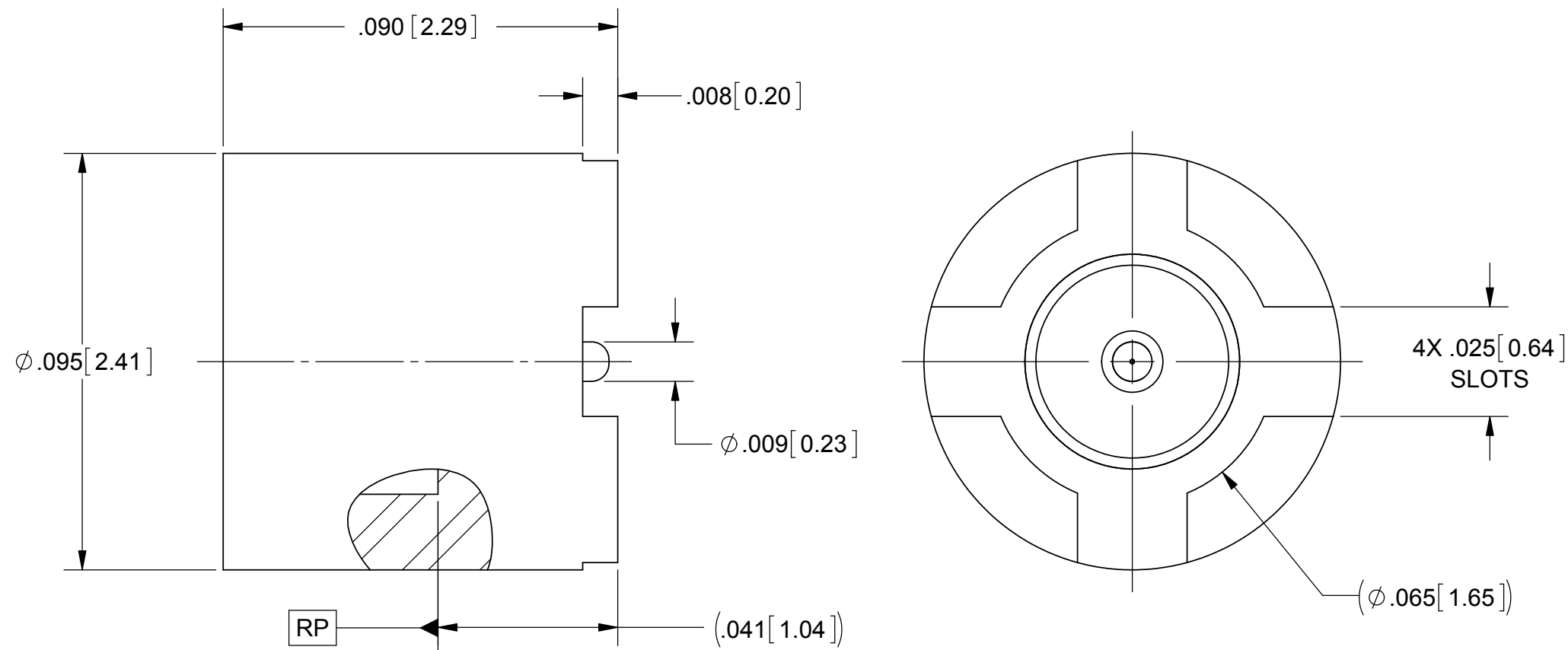

MATERIAL:
BODY: STAINLESS STEEL PER AMS-5640, ALLOY UNS S30300, TYPE 1
PIN: KOVAR PER ASTM-F15
GLASS: CORNING 7070 OR EQUIVALENT
FINISH:
BODY & PIN: GOLD PER ASTM B488, TYPE II, CODE C, CLASS 1.27, OVER NICKEL PER AMS-QQ-N-290, CLASS 1, .00005" MIN.

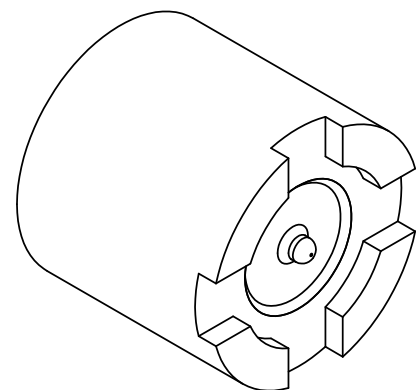
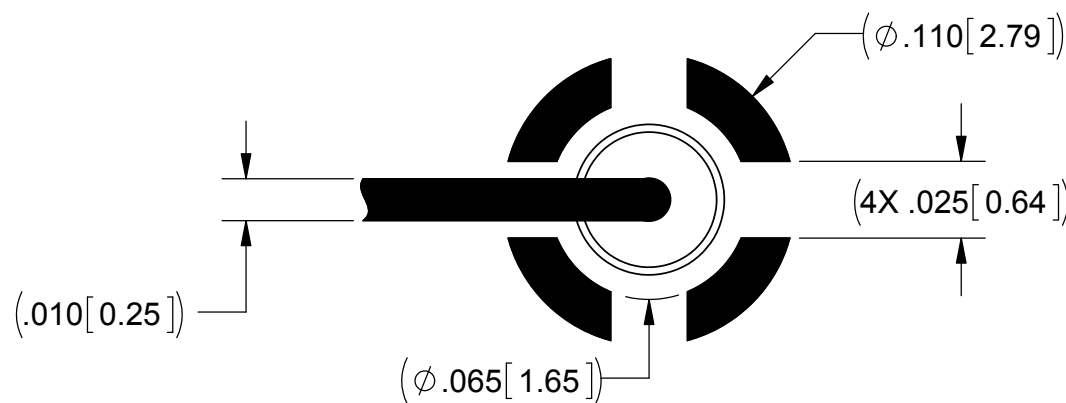

RECOMMENDED PCB LAYOUT

PERFORMANCE:
IMPEDANCE: 50 OHMS.
OPERATING TEMP.: -55 °C TO +125 °C.

NOTES:
 1. FOR A FOOTPRINT RECOMMENDATION SPECIFIC TO YOUR PCB, PLEASE CONTACT US AT applications@svmicro.com

SV P/N	INTERFACE
3811-60005	SMOOTH BORE
3811-60006	FULL DETENT

MATERIAL: SEE NOTES	DIMENSIONS ARE IN INCHES TOLERANCES: FRACTIONAL: $\pm 1/64$ ANGULAR: X° $\pm 1'0''$ X°X' $\pm 15''$	UNLESS OTHERWISE SPECIFIED 1) ALL DIMENSIONS ARE IN INCHES (MILLIMETERS) 2) ALL DIMENSIONS ARE AFTER PLATING. 3) BREAK CORNERS & EDGES .005 R. MAX. 4) CHAM. 1ST & LAST THREADS. 5) SURFACE ROUGHNESS 63-MIL-STD-10. 6) DIA.'S ON COMMON CENTERS TO BE CONCENTRIC WITHIN .005 T.I.R. 7) REMOVE ALL BURRS	SV Microwave, Inc. 2400 Centrepark West Drive, Suite 100 West Palm Beach, FL 33409 TITLE: SMPS MALE SURFACE MOUNT
FINISH: SEE NOTES	DECIMAL: X $\pm .030$.XX $\pm .010$.XXX $\pm .005$		
SURFACE AREA: N/A	INTERPRET DIMENSIONS AND TOLERANCES PER ASME Y14.5M - 1994	DRAWN: FED 09/01/11	SIZE: B CAGE CODE: 95077 DWG. NO. 3811-60005-60006
PROPRIETARY THE INFORMATION CONTAINED IN THIS DRAWING IS THE SOLE PROPERTY OF SV MICROWAVE, INC. ANY REPRODUCTION IN PART OR AS A WHOLE WITHOUT THE WRITTEN PERMISSION OF SV MICROWAVE, INC IS PROHIBITED.	THIRD ANGLE PROJECTION	CHECKED: STW 09/01/11	SCALE: 30:1
		APPROVED: STW 09/01/11	SHEET 1 OF 1