

THIS DRAWING IS UNPUBLISHED. RELEASED FOR PUBLICATION
 © COPYRIGHT - By - ALL RIGHTS RESERVED.

LOC	DIST	REVISIONS			
P	LTR	DESCRIPTION	DATE	DWN	APVD
H	-	J	ECR-07-020965	25-08-08	AEG MKO
		J1	REVISED PER ECO-09-020935	31AUG09	KK AEG
		J2	ECR-11-008320	18NOV11	RK MKO

- NOTES:
- 1 CONNECTOR MEETS THE REQUIREMENTS ACC. DIN 41612, PART 5.
 - 2 MATERIAL CONTACT: PHOSPHORBRONZE. MATERIAL HOUSING: GLASSFILLED THERM. POLYESTER. COLOR:GREY
 - 3 AT CONTACTAREA 1,25µm GOLD OVER 1,25µm NICKEL AT SOLDER POST AREA 1,25µm TIN.
 - 4 AT CONTACTAREA 0,8µm GOLD OVER 1,25µm NICKEL AT SOLDER POST AREA 1,25µm TIN.
 - 5 CONTACT ARRANGEMENTS; AN AN ASTERISK " X " DENOTES A SIGNAL CONTACT. AN ASTERISK " ⊗ " DENOTES A KINKED SIGNAL CONTACT.
 - 6 AT CONTACTAREA 0,4µm GOLD OVER 1,25µm NICKEL AT SOLDER POST AREA 1,25µm TIN.
 - 7 CONNECTOR PRINTED WITH PARTNUMBER AND DATECODE ON OUTSIDE OF MATING AREA AT SIDE OF ROW c.
 - 8 SOLDER POSTS SUITABLE FOR 1,0 NOM. P.C.B. HOLES.
 - 9 FLUX RESISTANCE STRIP.
 - 10 KINKED POSTS.
 - 11 AT CONTACTAREA 0,1µm GOLD OVER 0,7µm PALLADIUM (DURAGOLD) OVER 1,25µm NICKEL, AT SOLDERPOST AREA 1,25µm TIN.
 - 12 OBSOLETE PARTS: OBSOLETE CIS STREAMLINING PER D.RENAUD/D.SINISI

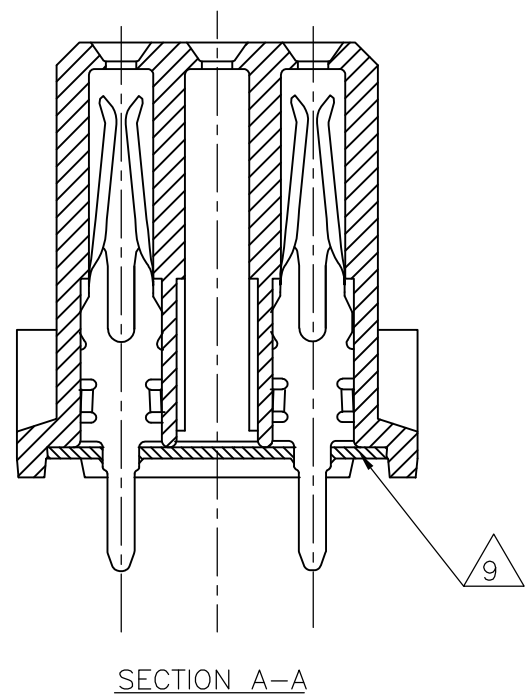
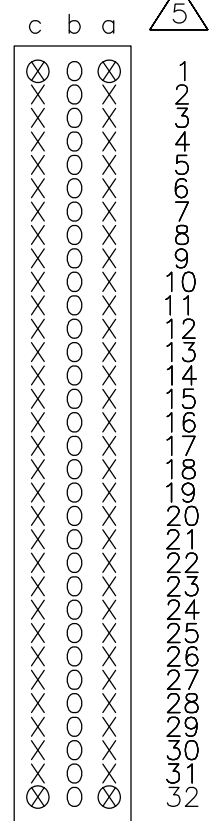
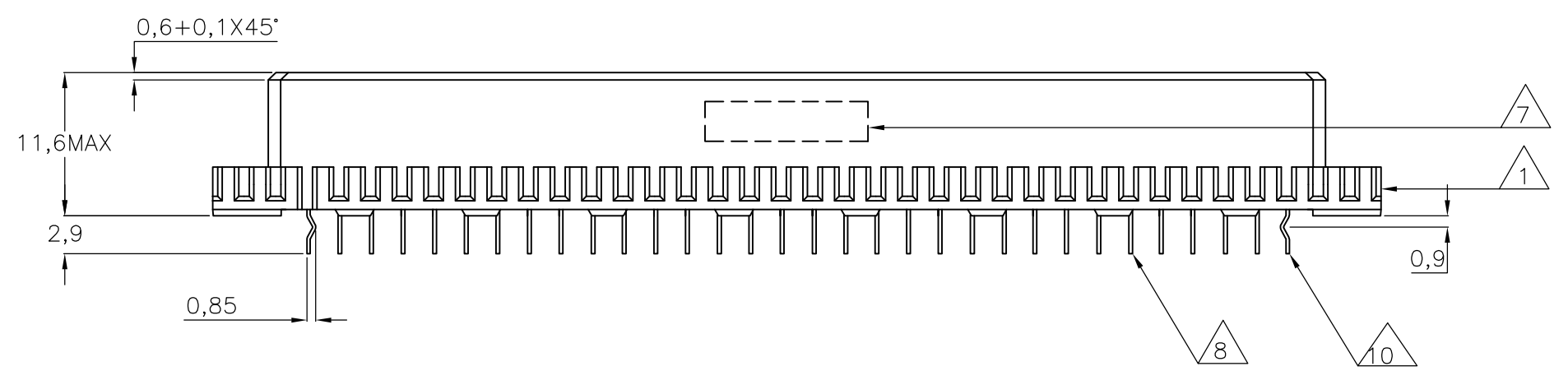
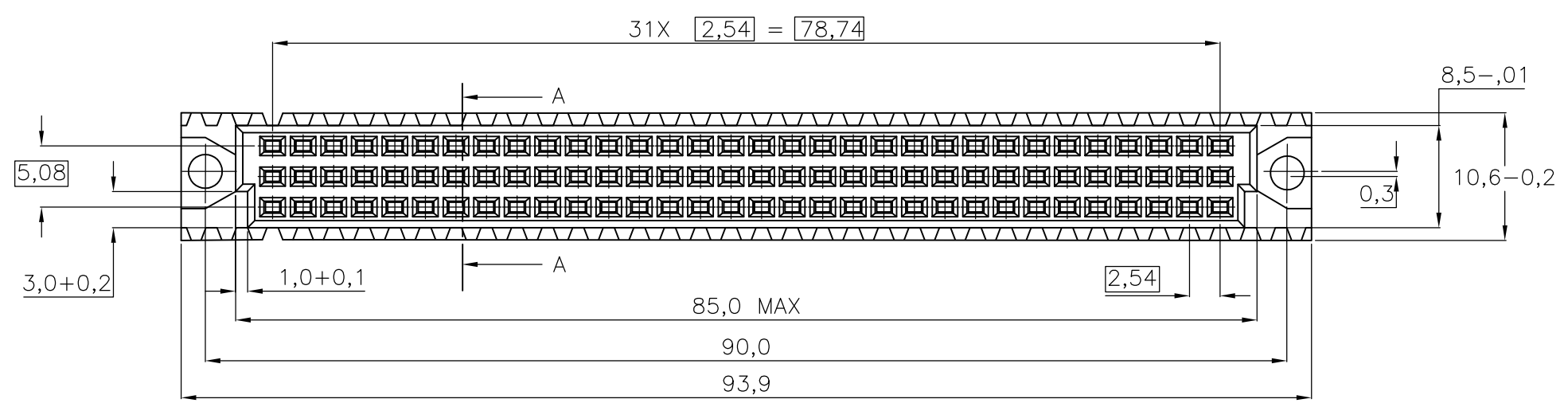

OBSOLETE	WITH	WITHOUT	11	2	7-216082-4
OBSOLETE	WITH	WITH	11	2	6-216082-4
OBSOLETE	WITH	WITHOUT	4	2	1-216082-4
OBSOLETE	WITH	WITH	6	2	216082-8
SUPERSEDED BY 2173045-4		WITH	4	2	216082-4
OBSOLETE	WITH	WITH	3	2	216082-1
			10	9	FINISH MATERIAL PARTNUMBER

THIS DRAWING IS A CONTROLLED DOCUMENT.

DWN J.V.LIEMPT. 19JUN91
 CHK J.GIBBELS
 APVD - NAME

STE TE Connectivity

64 POS C FEMALE B.T.B. CONN.
 ACC. DIN 41612 WITH SOLDER POSTS
 FOR 1,6 mm. P.C.BOARD THK'S.

DIMENSIONS: mm	TOLERANCES UNLESS OTHERWISE SPECIFIED:	PRODUCT SPEC	SIZE	CAGE CODE	DRAWING NO	RESTRICTED TO
	0 PLC ± -	-	A3	00779	C-216082	-
	1 PLC ± -	-	CUSTOMER DRAWING			SCALE NTS
	2 PLC ± -	-	SHEET 1 OF 1			REV J2
	3 PLC ± -	-				
	4 PLC ± -	-				
	ANGLES ± -	-				
MATERIAL -	FINISH -	WEIGHT -				