

PART NO.	ENG. NO.	TERM PATTERN		
		1	2	3
09-18-5032	A-1840-3-01	M	M	M
09-18-5031	A-1840-3-02	F	M	M
09-18-5037	A-1840-3-07	M	F	M
09-18-5930	A-1840-3-09	M	B	M

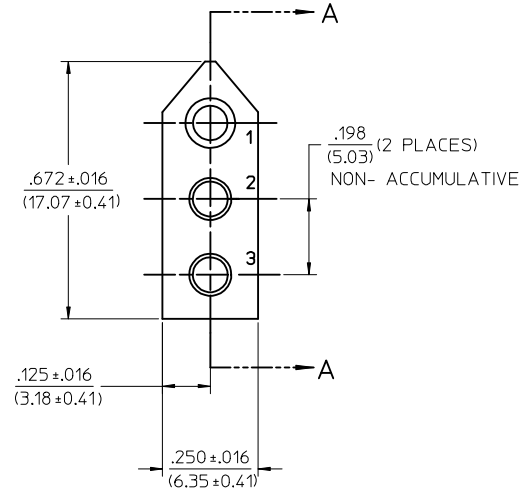
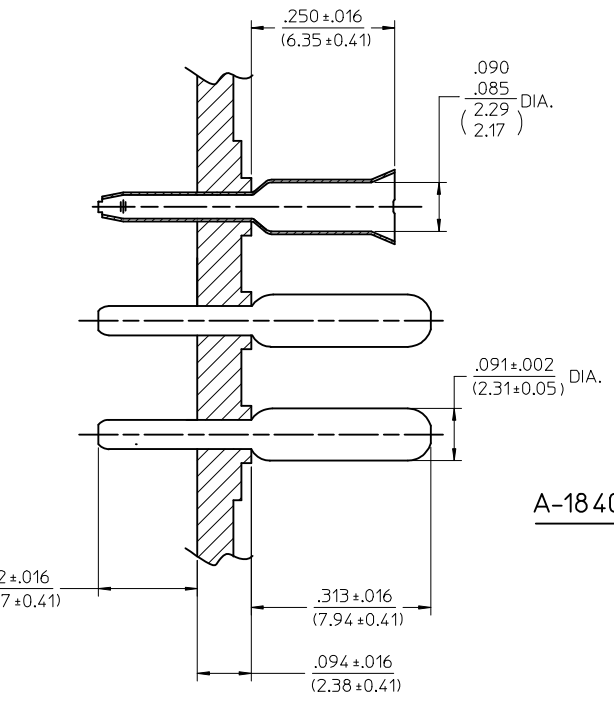
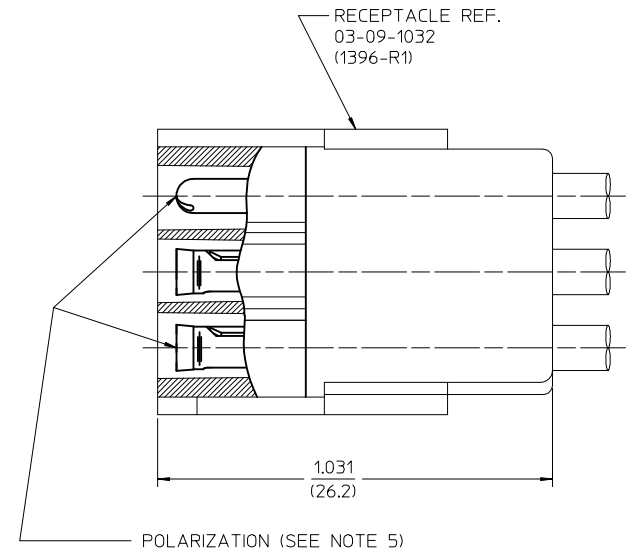
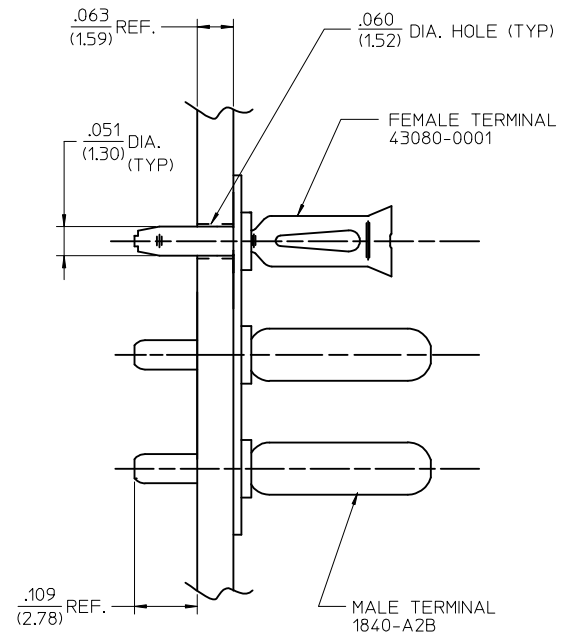

- NOTES:
- MATERIAL:
BASE AND RECEPTACLE: NYLON PA66, UL94V-0, COLOR: NATURAL
TERMINALS: MALE - BRASS ALLOY
FEMALE - PHOSPHOR BRONZE ALLOY
 - FINISH:
MALE TERMINALS: .000200/0.00508 MIN. TIN OVER
.000100/0.00254 MIN. COPPER
FEMALE TERMINALS: .000050/0.00127 MIN. TIN OVER
.000050/0.00127 MIN. NICKEL
 - PRODUCT SPECIFICATION: N/A
 - PACKAGING SPECIFICATION: PK-1840-001
 - POLARIZATION ACCOMPLISHED THROUGH AN INTER-MIX OF MALE AND FEMALE TERMINALS. (MOLEX .093 TERMINALS)
 - TERMINAL PATTERN CODE:
M = MALE TERMINALS
F = FEMALE TERMINALS
B = NO TERMINALS
 - PARTS TO BE MOUNTED ON SUPPORTED EDGE OF P.C. BOARD

SCALE: 4:1

A-1840-3-2 SHOWN

ADD PKG SPECS EC NO: UCP2013-4695 DRWN:MMSTROH 2011/10/18 CHKD:JBELL 2013/05/01 APPR:FSMITH 2013/05/13 V2	QUALITY SYMBOLS ▽=0 ▽=0 ▽=0	GENERAL TOLERANCES (UNLESS SPECIFIED)		DIMENSION STYLE IN/MM	SCALE 6:1	DESIGN UNITS INCH	THIRD ANGLE PROJECTION		
		4 PLACES ± --- ± ---	DRAWN BY EWC	DATE 1974/04/30	TITLE CONNECTOR-P.C. BOARD WAFERCONN 3 CIRCUIT				
		3 PLACES ± --- ± .010	CHECKED BY JBELL	DATE 2013/05/01	MOLEX INCORPORATED				
		2 PLACES ± 0.25 ± .015	APPROVED BY DATE		MATERIAL NO. SEE CHART	DOCUMENT NO. SDA-1840-3-*	SHEET NO. 1 OF 1		
1 PLACE ± 0.38 ± ---	ANGULAR ±1/2°		DRAFT WHERE APPLICABLE MUST REMAIN WITHIN DIMENSIONS						