

Rev	AWO #	Description	Date	Appr
-		RELEASED	02/07/13	

APPROVED: _____

DATE: _____ TITLE: _____

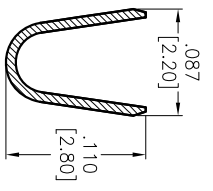

SECTION A-A

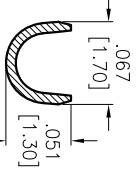

SECTION B-B

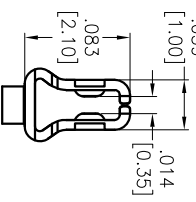

SECTION C-C

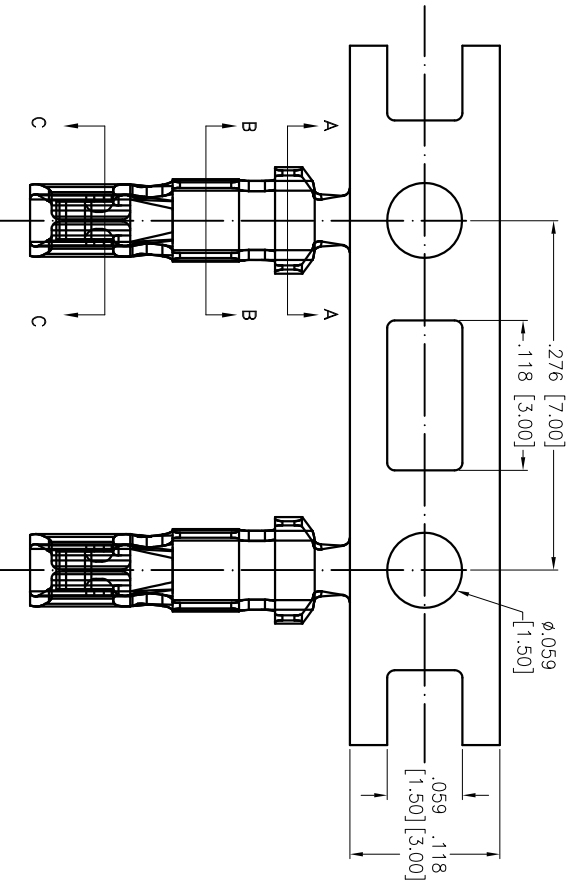
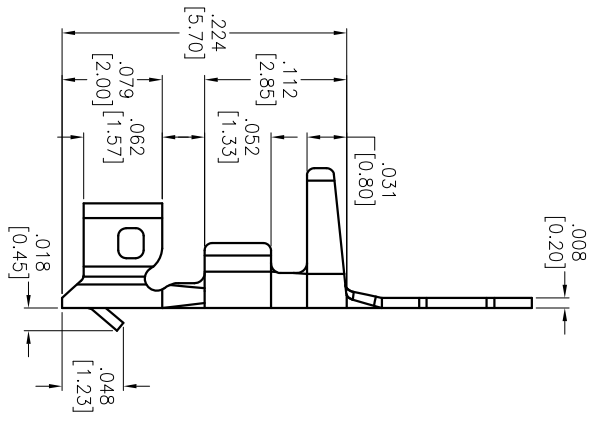

SPECIFICATIONS:

- Material: Phosphor Bronze
- Contact: Phosphor Bronze
- Thickness: 0.2mm
- Plating: Tin over Copper underplate overall
- Electrical:
 - Current rating: 2A AC/DC
 - Contact resistance: 20 mohms max
 - Insulation resistance: 1,000 Mohms min @ 500 VDC
 - Dielectric withstanding voltage: 800 VAC for 1 minute
 - Wire range: 22-28 AWG
 - Temperature Rating: Operating temperature: -25°C to +85°C
 - Environmental: Lead free, RoHS compliant

ADAM TECH
 909 Railway Avenue, Union, NJ 07083
 Phone: 908-687-5000 Fax: 908-687-5710

TITLE: CRIMP CONTACT

UNLESS OTHERWISE SPECIFIED ALL DIMENSIONS ARE INCHES [MM] TOLERANCES: EXCEPT AS NOTED	
INCHES	HOLDS
.X ± .10	ØX ± .10
.XX ± .020	ØXX ± .015
.XXX ± .015	ØXXX ± .010
APPROVALS	DATE
DRAWN TW	02/07/13
CHECKED CC	02/07/13
APPROVED	

SIZE X	PART NO. 2CTC-R	REV. -
REF: S00724T	SCALE: NTS	SHEET 1 OF 2



APPROVED: _____
 DATE: _____ TITLE: _____

Rev	AWO #	Description	Date	Appr
		SEE SHT 1 OF 2 FOR REVISION		

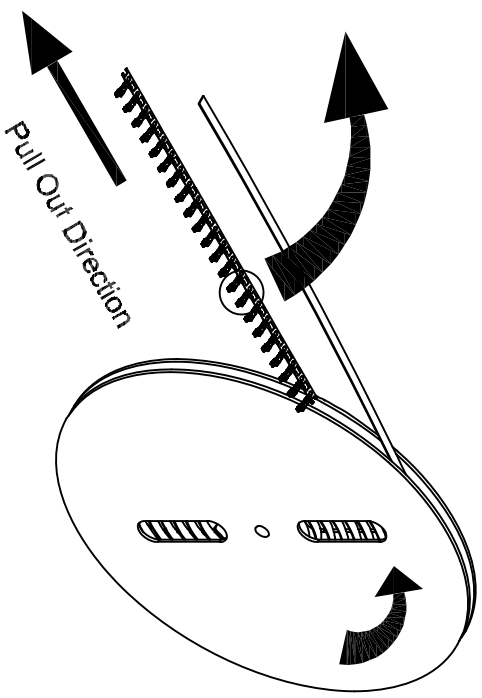
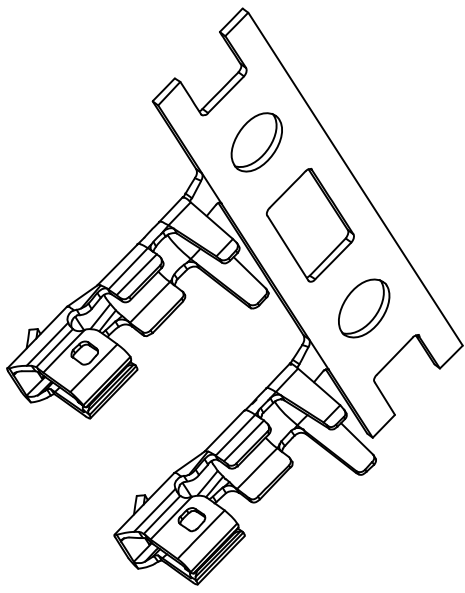

UNLESS OTHERWISE SPECIFIED ALL DIMENSIONS ARE INCHES [MM]	
TOLERANCES: EXCEPT AS NOTED	
INCHES	HOLES
.X ± .10	ØX ± .10
.XX ± .020	ØXXX ± .015
.XXX ± .015	ØXXXX ± .010
APPROVALS	DATE
DRAWN TW	02/07/13
CHECKED CC	02/07/13
APPROVED	

ADAM TECH
 909 Railway Avenue, Union, NJ 07083
 Phone: 908-687-5000 Fax: 908-687-5710

CRIMP CONTACT

SIZE	PART NO.	REV.
X	2CTC-R	-
REF:	SCALE:	SHEET
S00124T	NTS	2 OF 2

