

REVISIONS		RELEASED	DATE	APPROVED
REV. ECH. No.	DESCRIPTION			
A	A1 AND A2 TERMINALS RE-IDENTIFIED		96/01/26	RS
B	32516 FIND NOS 11 & 12 ADDED		97/03/10	RS

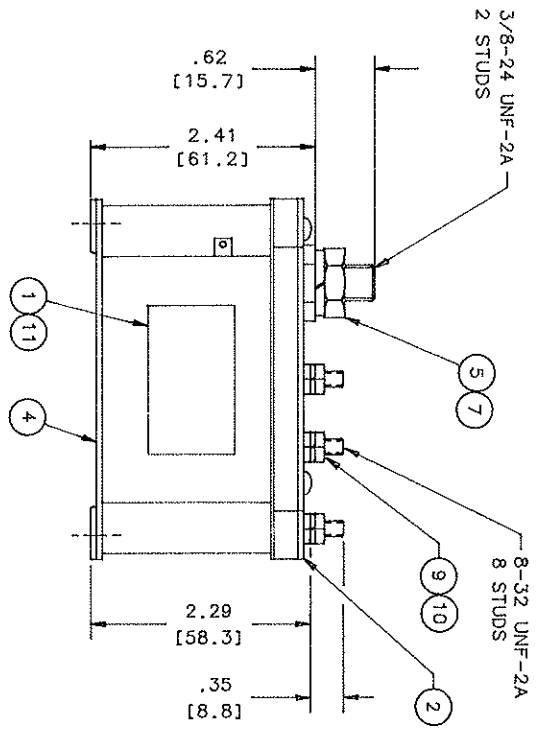
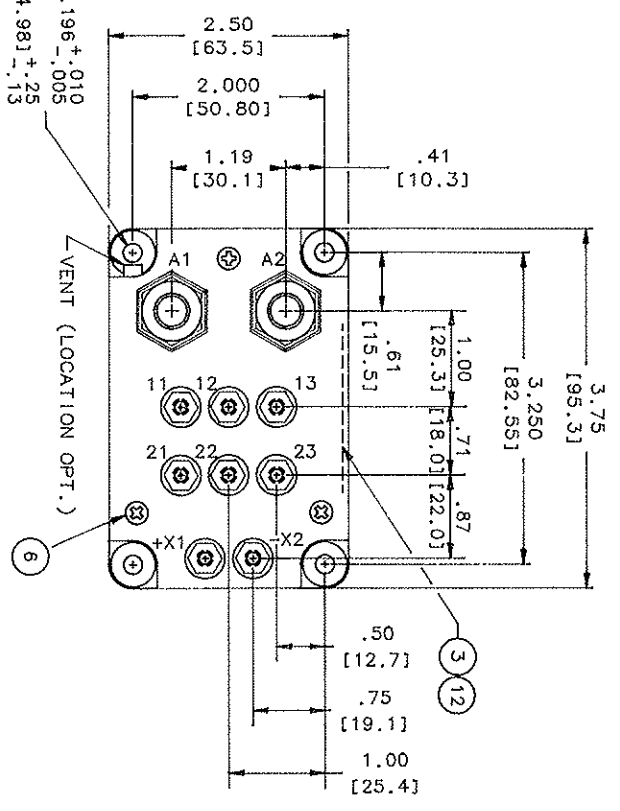

NOTES:  
 1. THIS UNIT MEETS THE MATERIAL AND WORKMANSHIP REQUIREMENTS OF MIL-R-6106J.  
 2. DIMENSIONS IN BRACKETS ARE IN MILLIMETERS.

CONSTRUCTION  
 MAIN CONTACTS  
 VOLTAGE  
 CURRENT  
 NOMINAL INRUSH CARRY

GASKET SEALED (VENTED)  
 SPST N.O.  
 28 VDC  
 400 AMP  
 1200 AMP  
 800 AMP FOR 30 SEC.

AUXILIARY CONTACTS  
 CONFIGURATION  
 VOLTAGE  
 CURRENT RES

2PDT  
 28 VDC  
 5 AMP

COIL DATA  
 DUTY CYCLE  
 MAX OPERATE VOLTAGE  
 NOM OPERATE VOLTAGE  
 MAX PICKUP VOLTAGE  
 DROPOUT VOLTAGE  
 COIL RESISTANCE @ 25°C

CONTINUOUS  
 30 VDC  
 28 VDC  
 18 VDC  
 1 - 7 VDC  
 60 OHM ± 10%

TRANSIENT SUPPRESSION  
 OPERATE TIME

45 V MAX  
 35 MS MAX

ENVIRONMENTAL DATA  
 AMBIENT TEMP.  
 ALTITUDE  
 LIFE ELECTRICAL  
 LIFE MECHANICAL  
 WEIGHT (MAX)

-55°C TO 71°C  
 50,000 FEET MAX  
 50,000 CYCLES MIN.  
 100,000 CYCLES MIN.  
 1.35 LBS. (.613 kg)

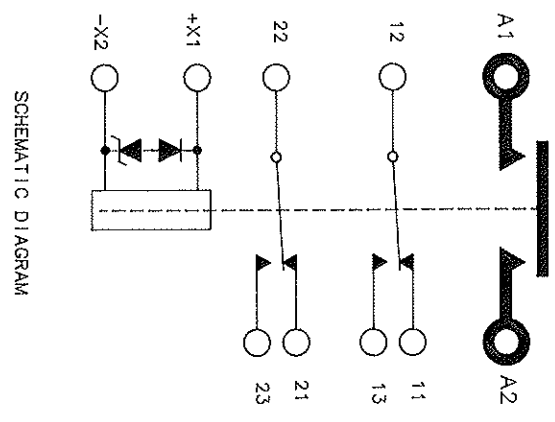

FIND NO	QTY	PART OR IDENTIFYING NO	NOMENCLATURE OR DESCRIPTION	FMSA NO	DRAWING OR SPECIFICATION	MATERIAL OR NOTE
12	1	39529-051	OVERLAY			
11	1	39529-001	OVERLAY			
10	8	50408-034	NUT 8-32 X 5/16 X 3/32 HEX.			BRASS
9	8	51808-064	WASHER-LOCK NO. 8 .307 X .047			BRONZE
7	2	51807-084	WASHER-LOCK NO. 3/8 SPLIT TYP.			BRONZE
6	3	51200-020	SCREW NO. 4 X 1/4 PAN HD.			ST. STEEL
5	2	50407-164	NUT 3/8-24 X 5/8 X 7/32 HEX			BRASS
4	1	44087-010	CONTACTOR ASSEMBLY-PRI.			
3	1	44090-001	PLATE-WIRING DIAGRAM			
2	1	44088-001	PLATE-BASE COVER			
1	1	16043-001	PLATE-NAME			

UNLESS OTHERWISE SPECIFIED TOLERANCES IN INCHES	REF. MHI LTD.	HARTMAN ELECTRICAL MANUFACTURING MANSPFIELD, OHIO
1 PL DEC. 13 PL DEC. ANGLES	DR BY RLS 97/03/20	LINE CONTACTOR CONT. DUTY
2 PL DEC. 13 PL DEC. ANGLES	CHK BY RS 97/03/20	400 AMP, 28VDC
4.06 ± .010 ± 1°	ENG BY DM 4/16/20	SIZE CODE IDENT DWG NO.
1 PL DEC. 12 PL DEC. ANGLES	MFG BY DM 4/16/20	A 74063 A-400B
± 1.5 ± .25 ± 1°	RELEASE 4/16/20	SCALE 1:2 SHEET
	CONTR. NO.	
	GOVT APPVL	