

# Intelligent Display Module with 3.5" Landscape Display

## Ordering Information

Product No.	Description
MDL-IDM-L35	Stellaris® Intelligent Display Module with 3.5" Landscape Display for Single-Unit Packaging
MDL-IDM-L35-B	Stellaris® Intelligent Display Module with 3.5" Landscape Display for Volume Packaging
RDK-IDM-L35	Stellaris® Intelligent Display Module with 3.5" Landscape Display Reference Design Kit (includes MDL-IDM-L35 board)



Figure 1. Intelligent Display Module with 3.5" Landscape Display RDK

## Contents

General Description .....	1
Feature Summary .....	2
Module Block Diagram .....	3
Operational Specifications .....	3
Power .....	4
Wiring .....	4
Software Development .....	5
Programming the MDL-IDM-L35 .....	6
Reference Design Kit Contents .....	6
Mechanical Installation .....	6
Additional Information .....	7

## General Description

The Stellaris® Intelligent Display Module with 3.5" Landscape Display (MDL-IDM-L35-L35) offer a complete graphical touch-screen user interface solution for control, automation, and instrumentation applications. The compact design is based on a Stellaris® LM3S1958 microcontroller; a highly integrated controller incorporating a 32-bit ARM® Cortex™-M3 core.

Development of software for the IDM module is simplified by using the comprehensive Stellaris graphics library and ARM development tools from our tools partners. First-time users should purchase the RDK-IDM-L35 Reference Design Kit which includes the touch panel module, a documentation CD, and cables.

See the *RDK-IDM-L35 Quickstart Guide* and *RDK-IDM-L35 User's Manual* for complete technical details on using and customizing the Intelligent Display Module.

## Feature Summary

Highlighted capabilities of the MDL-IDM-L35 include:

- Bright QVGA LCD Display with touch
- Serial connectivity
- Easy to customize – full source code and design files included
- Flexible power supply options
- Compact size simplifies system integration

## Features

The MDL-IDM-L35 provides the following features:

- LCD display
  - 3.5" QVGA 320 x 240 pixels
  - 16-bit color
  - White LED backlight
  - 4-wire resistive touch panel
- Serial communications
  - UART serial port with RS232 signal levels
  - UART serial port with TTL signal levels
  - Default 115.2k,8,n,1 operation
- Stellaris® microcontroller
  - 32-bit ARM® Cortex™-M3
  - 50 MHz operation
- Memory
  - 256 KB main flash memory
  - 64 KB SRAM
  - 168 KB image RAM
  - microSD slot (typically 1 GB storage)
- Power-supply options
  - 5 V DC jack
  - 5 V Terminal block
  - 5 V Serial header
- Peripherals
  - Four analog measurement inputs
  - 16 digital I/O lines
  - Magnetic buzzer, PWM controlled
- Software
  - Example applications included
  - Supports development tools from Keil, IAR, Code Sourcery, and Code Red Technologies
  - Stellaris® Graphics Library

## Module Block Diagram

Figure 2 shows the block diagram for the MDL-IDM-L35.

Figure 2. Block Diagram

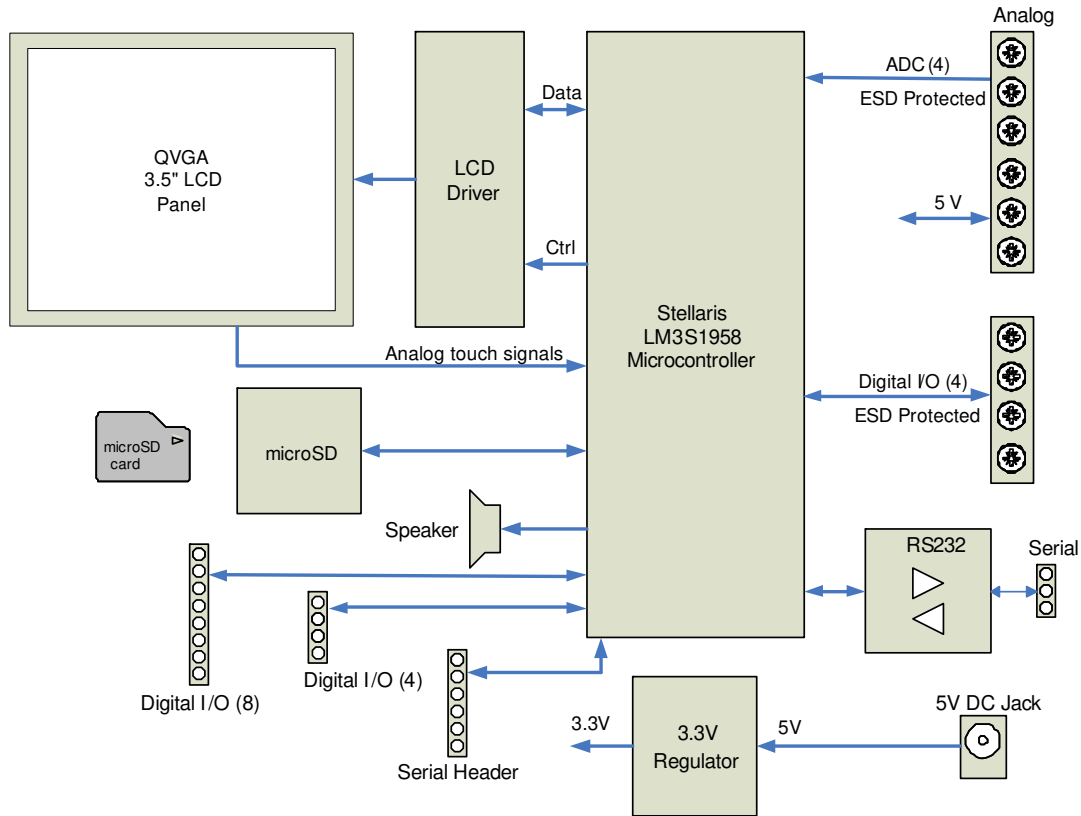

## Operational Specifications

Table 1 shows the operating parameters for the MDL-IDM-L35.

Table 1. Operating Specifications

Parameter Name	Min	Nom	Max	Unit
<b>Power Supply Connection Options</b>				
DC Jack J7	4.5	5	5.5	V DC
Terminal Block J1				
Serial Header J8				
Required Supply Current	-	-	300	mA
<b>Environment</b>				
Operating Temperature Range	-20	-	+50	°C
Storage Temperature Range	-30	-	+70	°C

# BOARD DATA SHEET



**Table 1. Operating Specifications (Continued)**

Parameter Name	Min	Nom	Max	Unit
<b>Display</b>				
Brightness	210	220	–	Cd/m <sup>2</sup>
View Angle (V)	-10	–	+35	deg
View Angle (H)	-45	–	+45	deg
Contrast Ratio	340	400	–	–
<b>Peripherals</b>				
Analog Input Range	0	–	3	V
Analog Inputs – Electrical Limits	-0.3	–	3.3	V
Digital Inputs - Low level (VIL)	-0.3	–	0.8	V
Digital Inputs - High level (VIH)	2.0	–	5.0	V
Digital Outputs - Low level (VOL)	–	–	0.4	V
Digital Outputs - High level (VOH)	2.4	–	–	V
<b>RS232</b>				
Data Rate	–	–	120	Kbps
Transmitter Voltage Swing	±5.0	±5.4	–	Vdc
Input Threshold Low	0.6	1.2	–	–
Input Threshold High	–	1.5	2.4	–

## Power

The IDM-L35 requires 5 V DC for operation, which can be applied to one of the three power supply board connectors (see page 3). The RDK includes a USB serial cable that provides power via the serial header connector. In all cases, the power supply must be regulated within the electrical limits listed in Table 1.

## Wiring

Figure 3 shows all possible electrical connections, including RS232, analog inputs, and digital I/O. The actual functionality of the peripheral connections is determined by the application software.

# BOARD DATA SHEET

Figure 3. Connection Diagram

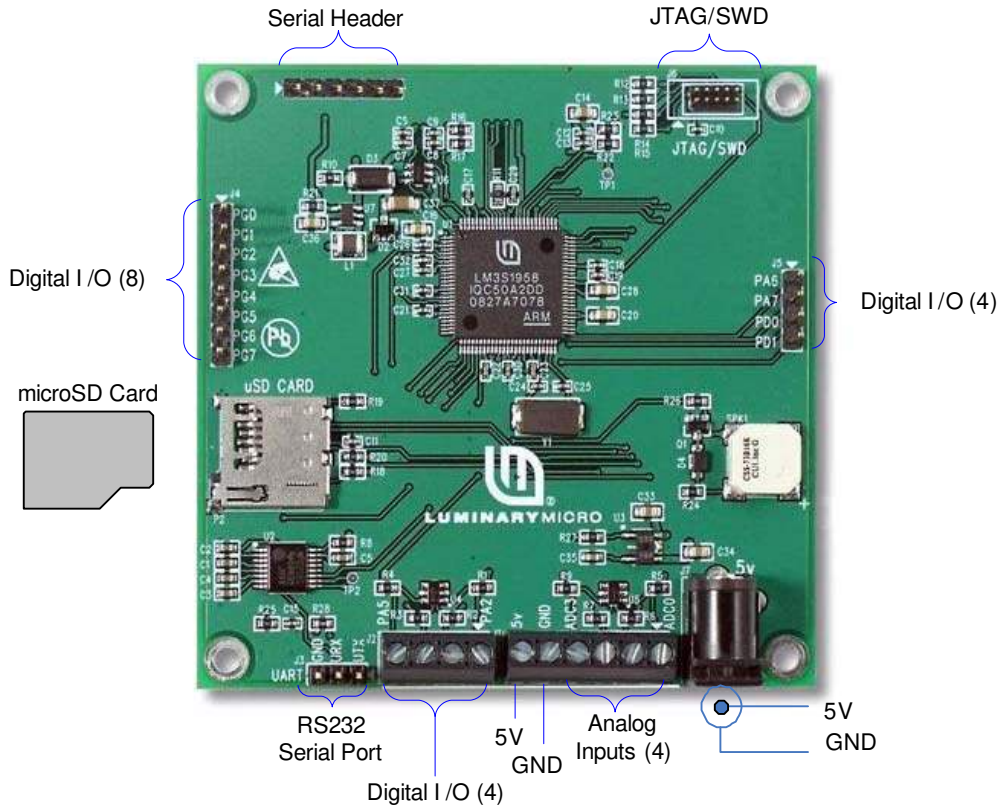

## Software Development

The MDL-IDM-L35 ships with a factory-programmed example application. This application must be replaced with a program specific to the end product. Development requires the use of a compiler capable of generating code for an ARM® Cortex™-M3 processor. Visit [www.luminarymicro.com](http://www.luminarymicro.com) to download evaluation versions of suitable development tools.

The Stellaris Graphics Library accelerates software development by providing a range of display-related extensions to the standard StellarisWare™ Software. The Graphics Library includes widgets, low-level drawing primitives, and display drivers.

Graphics Library widgets encapsulate the ability to render a GUI element, detect if a touchscreen press occurred within its bounds, and react to presses. Widgets may be used in a hierarchical manner to provide groups of associated widgets, such as radio buttons. Examples of widgets include check boxes, buttons, sliders, and images.

Drawing primitives are elementary geometric items. The Graphics Library includes primitives such as lines, circles, filled circles, rectangles, and fonts. A selection of pre-built fonts is included and additional user fonts may be added to the library.

The display driver provides low-level code for initializing the display controller and a method for setting pixels. Graphics Library includes a display driver optimized for the RDK-IDM-L35 LCD panel and therefore, users do not need low-level knowledge of LCD-driver operation.

Refer to the *Stellaris® Graphics Library User's Guide* for full details.



## Programming the MDL-IDM-L35

Once an application has been compiled and linked to a binary file, it can be loaded into the MDL-IDM-L35 by two different methods:

- Over the RS232 serial port using the Stellaris serial boot loader
- Using the JTAG or SWD port and an In-circuit Debug Interface (ICDI)

Both methods are supported by the LMFlash utility included on the software and documentation CD and available from the [www.luminarymicro.com](http://www.luminarymicro.com) web site.

The RDK-IDM-L35 includes an adapter to convert the fine-pitch, 10-way debug header to the common 20-pin ARM debug header.

**Figure 4. Fine-Pitch Debug Header Pin Assignments**

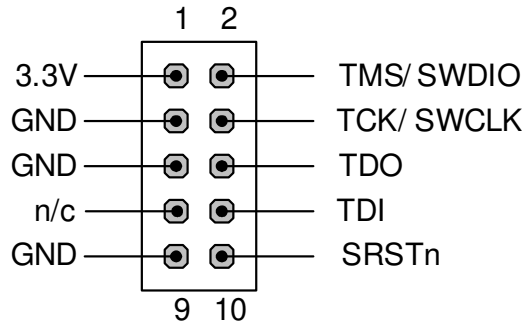

## Reference Design Kit Contents

The RDK-IDM-L35 RDK includes the following:

- MDL-IDM-L35 Intelligent QVGA Touch Panel with Ethernet
- USB to TTL serial USB cable
- Debug adapter
  - Fine pitch to 0.1" standard header
- Documentation and source code CD

## Mechanical Installation

The MDL-IDM-L35 mounts to a front panel mounting using four screws and appropriate stand-offs.

**Figure 5. MDL-IDM-L35 Module Dimensions**

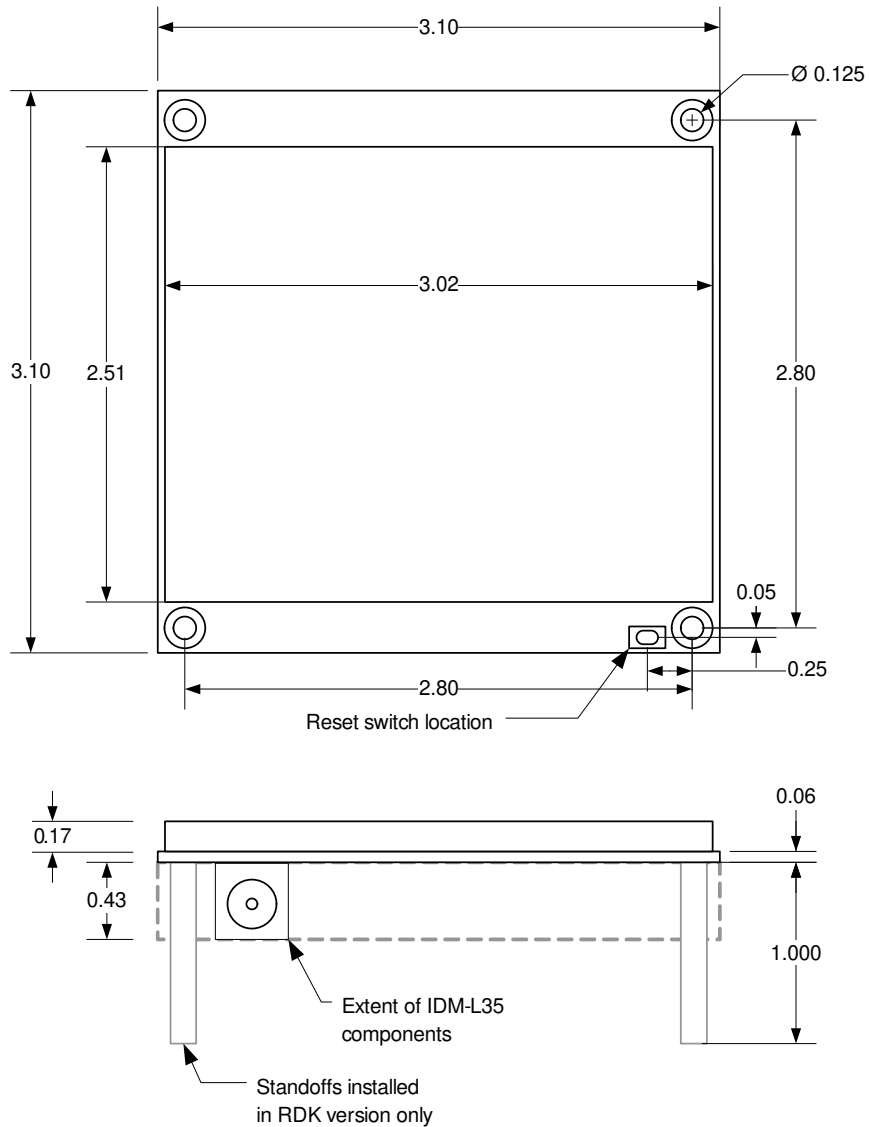

## Additional Information

The following documents are available for download at [www.luminarymicro.com](http://www.luminarymicro.com):

- *Stellaris® Intelligent Display Module with 3.5" Landscape Display Reference Design Kit User's Manual*, document order number RDK-IDM-L35
- *Stellaris Peripheral Driver Library User's Guide*, document order number SW-DRL-UG
- *Stellaris Graphics Library User's Guide*, document order number SW-GRL-UG
- *RDK-IDM-L35 Firmware Development Package User's Guide*, document order number SW-RDK-IDM-L35

## Important Notice

Texas Instruments Incorporated and its subsidiaries (TI) reserve the right to make corrections, modifications, enhancements, improvements, and other changes to its products and services at any time and to discontinue any product or service without notice. Customers should obtain the latest relevant information before placing orders and should verify that such information is current and complete. All products are sold subject to TI's terms and conditions of sale supplied at the time of order acknowledgment.

TI warrants performance of its hardware products to the specifications applicable at the time of sale in accordance with TI's standard warranty. Testing and other quality control techniques are used to the extent TI deems necessary to support this warranty. Except where mandated by government requirements, testing of all parameters of each product is not necessarily performed.

TI assumes no liability for applications assistance or customer product design. Customers are responsible for their products and applications using TI components. To minimize the risks associated with customer products and applications, customers should provide adequate design and operating safeguards.

TI does not warrant or represent that any license, either express or implied, is granted under any TI patent right, copyright, mask work right, or other TI intellectual property right relating to any combination, machine, or process in which TI products or services are used. Information published by TI regarding third-party products or services does not constitute a license from TI to use such products or services or a warranty or endorsement thereof. Use of such information may require a license from a third party under the patents or other intellectual property of the third party, or a license from TI under the patents or other intellectual property of TI.

Reproduction of TI information in TI data books or data sheets is permissible only if reproduction is without alteration and is accompanied by all associated warranties, conditions, limitations, and notices. Reproduction of this information with alteration is an unfair and deceptive business practice. TI is not responsible or liable for such altered documentation. Information of third parties may be subject to additional restrictions.

Resale of TI products or services with statements different from or beyond the parameters stated by TI for that product or service voids all express and any implied warranties for the associated TI product or service and is an unfair and deceptive business practice. TI is not responsible or liable for any such statements.

TI products are not authorized for use in safety-critical applications (such as life support) where a failure of the TI product would reasonably be expected to cause severe personal injury or death, unless officers of the parties have executed an agreement specifically governing such use. Buyers represent that they have all necessary expertise in the safety and regulatory ramifications of their applications, and acknowledge and agree that they are solely responsible for all legal, regulatory and safety-related requirements concerning their products and any use of TI products in such safety-critical applications, notwithstanding any applications-related information or support that may be provided by TI. Further, Buyers must fully indemnify TI and its representatives against any damages arising out of the use of TI products in such safety-critical applications.

TI products are neither designed nor intended for use in military/aerospace applications or environments unless the TI products are specifically designated by TI as military-grade or "enhanced plastic." Only products designated by TI as military-grade meet military specifications. Buyers acknowledge and agree that any such use of TI products which TI has not designated as military-grade is solely at the Buyer's risk, and that they are solely responsible for compliance with all legal and regulatory requirements in connection with such use.

TI products are neither designed nor intended for use in automotive applications or environments unless the specific TI products are designated by TI as compliant with ISO/TS 16949 requirements. Buyers acknowledge and agree that, if they use any non-designated products in automotive applications, TI will not be responsible for any failure to meet such requirements.

Following are URLs where you can obtain information on other Texas Instruments products and application solutions:

### Products

Amplifiers	<a href="http://amplifier.ti.com">amplifier.ti.com</a>
Data Converters	<a href="http://dataconverter.ti.com">dataconverter.ti.com</a>
DLP® Products	<a href="http://www.dlp.com">www.dlp.com</a>
DSP	<a href="http://dsp.ti.com">dsp.ti.com</a>
Clocks and Timers	<a href="http://www.ti.com/clocks">www.ti.com/clocks</a>
Interface	<a href="http://interface.ti.com">interface.ti.com</a>
Logic	<a href="http://logic.ti.com">logic.ti.com</a>
Power Mgmt	<a href="http://power.ti.com">power.ti.com</a>
Microcontrollers	<a href="http://microcontroller.ti.com">microcontroller.ti.com</a>
RFID	<a href="http://www.ti-rfid.com">www.ti-rfid.com</a>
RF/IF and ZigBee® Solutions	<a href="http://www.ti.com/lprf">www.ti.com/lprf</a>

### Applications

Audio	<a href="http://www.ti.com/audio">www.ti.com/audio</a>
Automotive	<a href="http://www.ti.com/automotive">www.ti.com/automotive</a>
Broadband	<a href="http://www.ti.com/broadband">www.ti.com/broadband</a>
Digital Control	<a href="http://www.ti.com/digitalcontrol">www.ti.com/digitalcontrol</a>
Medical	<a href="http://www.ti.com/medical">www.ti.com/medical</a>
Military	<a href="http://www.ti.com/military">www.ti.com/military</a>
Optical Networking	<a href="http://www.ti.com/opticalnetwork">www.ti.com/opticalnetwork</a>
Security	<a href="http://www.ti.com/security">www.ti.com/security</a>
Telephony	<a href="http://www.ti.com/telephony">www.ti.com/telephony</a>
Video & Imaging	<a href="http://www.ti.com/video">www.ti.com/video</a>
Wireless	<a href="http://www.ti.com/wireless">www.ti.com/wireless</a>

Mailing Address: Texas Instruments, Post Office Box 655303, Dallas, Texas 75265  
 Copyright © 2009, Texas Instruments Incorporated

Copyright © 2007–2009 Texas Instruments, Inc. All rights reserved.  
 Stellaris and StellarisWare are registered trademarks of Texas Instruments. ARM and Thumb are registered trademarks, and Cortex is a trademark of ARM Limited. Other names and brands may be claimed as the property of others.

