



25.4GHz Surface Mount LPF

L254XF3S



DLI • Novacap • Syfer • Voltronics

www.dilabs.com

www.knowlescapacitors.com

DESCRIPTION

DLI introduces its new high frequency surface mountable catalog low pass filters. These LPF's incorporate DLI's high dielectric ceramic materials which provide small size and minimal performance variation over temperature. The catalog LPF's are offered in a variety of frequency bands, which offers a drop in solution for high frequency attenuation.

FEATURES

- Small Size
- Fully Shielded Component
- Frequency Stable over Temperature
- Solder Surface Mountable
- Excellent Repeatability
- Operating Temp: -55°C to +125°C
- Characteristic Impedance: 50Ω
- 100% Tested & Inspected

SPECIFICATIONS*

Parameter	Frequency (GHz)	Min	Max
Passband Insertion Loss*	DC - 25		1.6
Min Passband Return Loss	DC - 25	15	
Stopband Attenuation (dB)	29 - 50	30	
Size (LxWxH)	0.220 x 0.140 x 0.098 in		

*Electrical specifications based on typical mounted performance at room temperature. Insertion loss shall vary ±0.5dB over temperature.

Typical Measured Performance

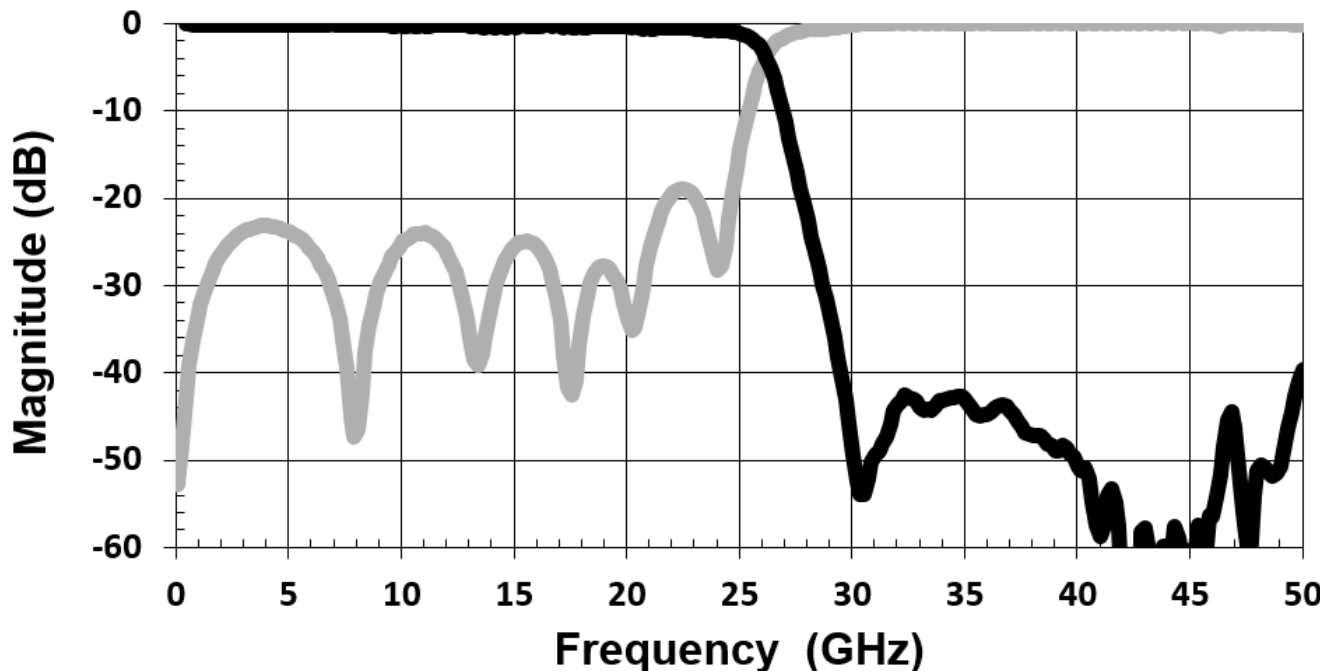



25.4GHz Surface Mount LPF

L254XF3S



DLI • Novacap • Syfer • Voltronics

www.dilabs.com

www.knowlesc capacitors.com

Typical Loss in Passband

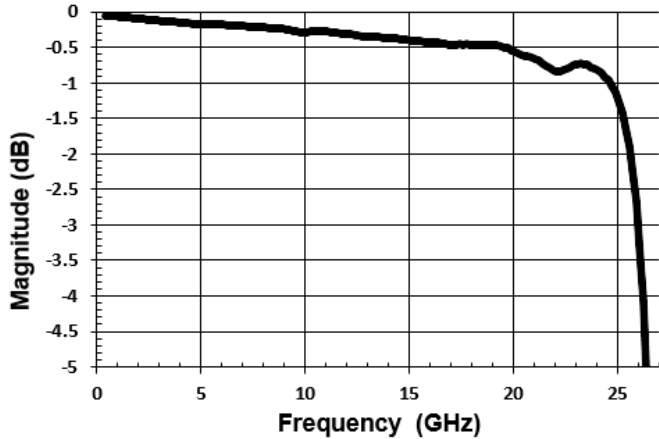

Typical Group Delay

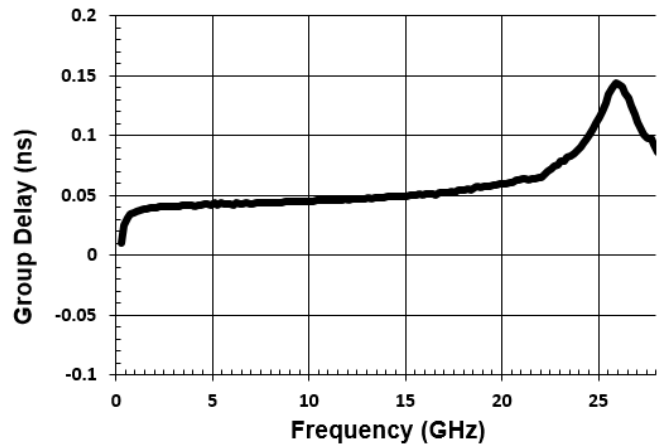

Physical Dimensions

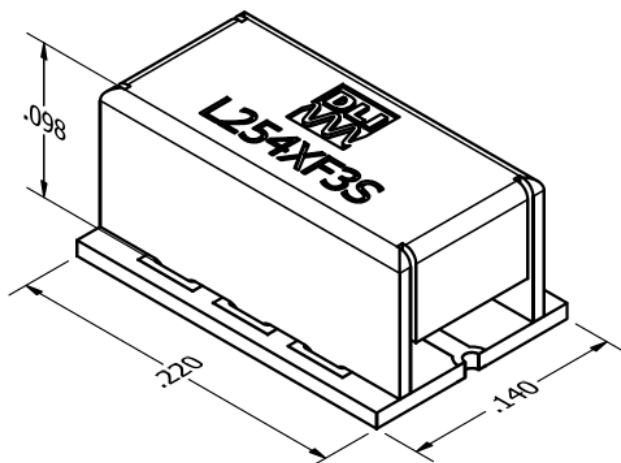

Isometric View

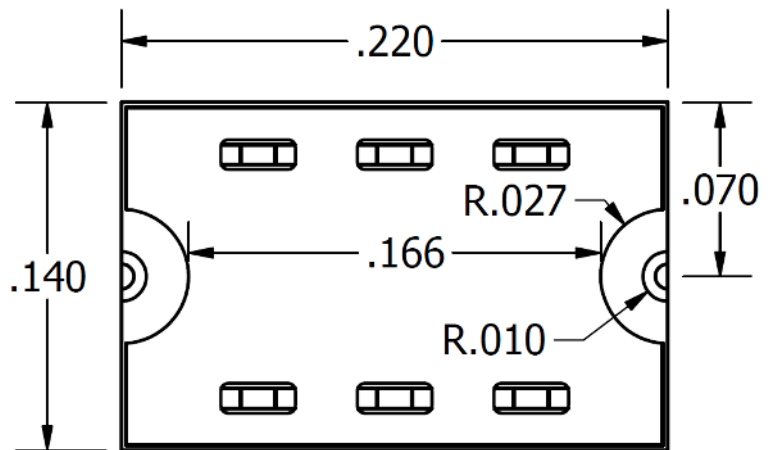

Bottom View

Recommended PCB Layout

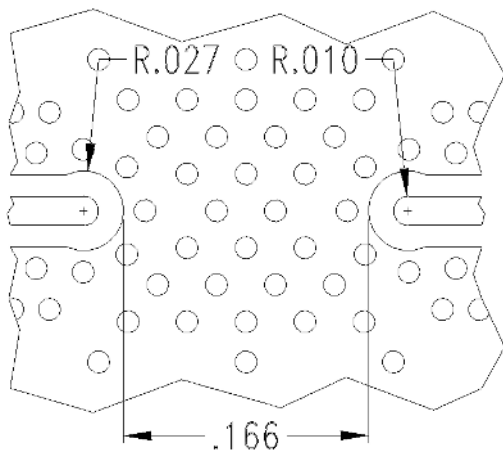

- 50Ω trace dimensions are application specific.
- Ensure adequate grounding beneath the filter.



2777 Route 20 East, Cazenovia, NY 13035 | Ph: (315)655-8710 | KCCSales@knowles.com