

- MATERIAL: HOUSING- HTN MOLDING COMPOUND, 94VO, COLOR: BLACK.
TERMINAL- 0.36 [.014] THICK PHOS BRONZE PLATED WITH 1.27µm [.000050] MINIMUM THICK HARD GOLD IN LOCALIZED GOLD PLATE AREA AND 3.81µm [.000150] MINIMUM THICK MATTE TIN IN SOLDER AREA OVER 1.27µm [.000050] MINIMUM THICK NICKEL UNDERPLATE.
- CAVITY CONFORMS TO FCC RULES AND REGULATIONS PART 68, SUBPART F.
- SNAP-IN RETENTION FEATURE ACCOMMODATES A 1.57±0.13 [.062±.005] THICK PRINTED CIRCUIT BOARD.
- DIMENSIONS ARE MAXIMUM UNLESS OTHERWISE SPECIFIED AND ARE PRIOR TO SURFACE MOUNT PROCESSING.
- TERMINALS ASSEMBLED IN CENTER POSITIONS FOR -2.

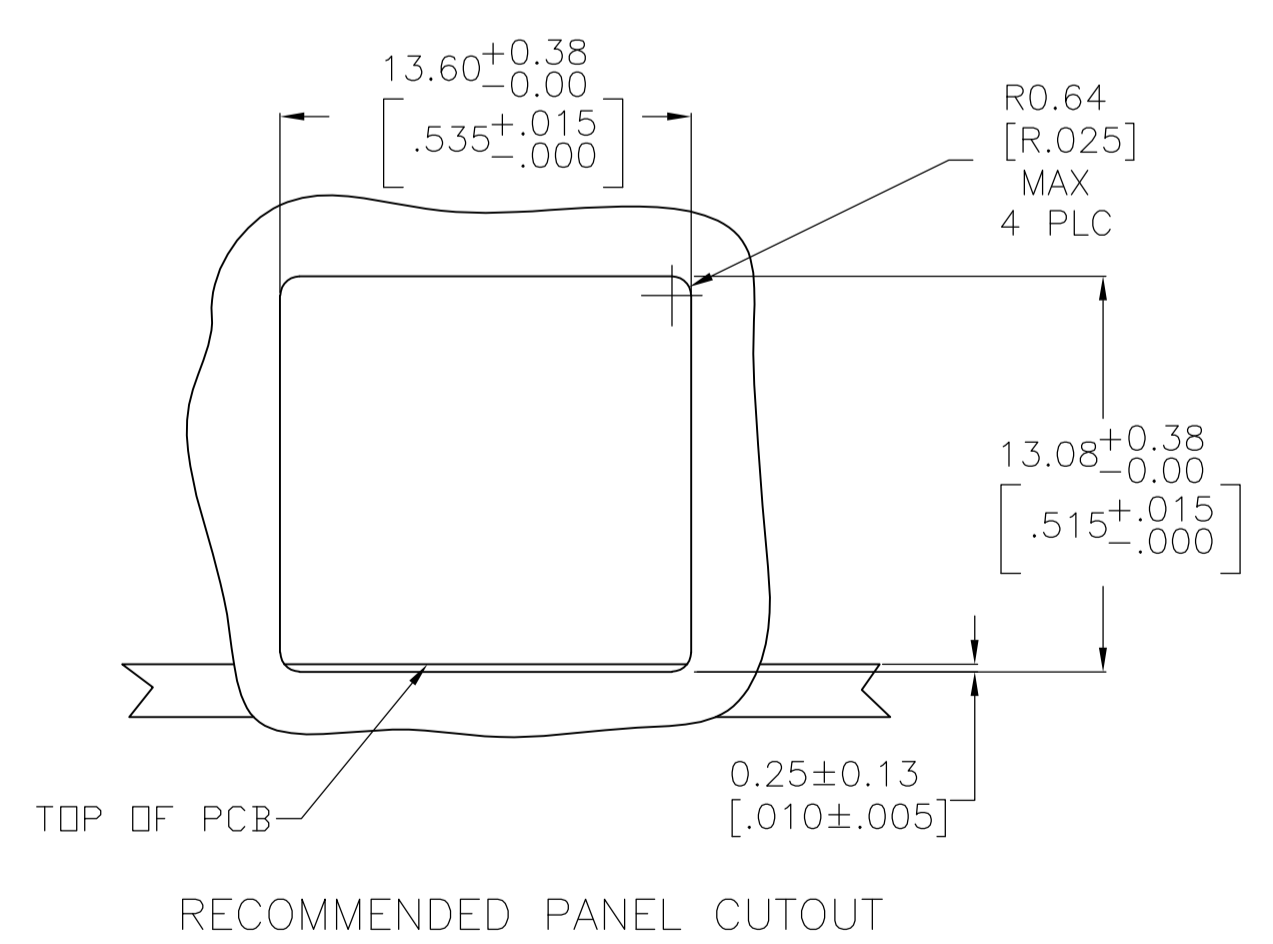
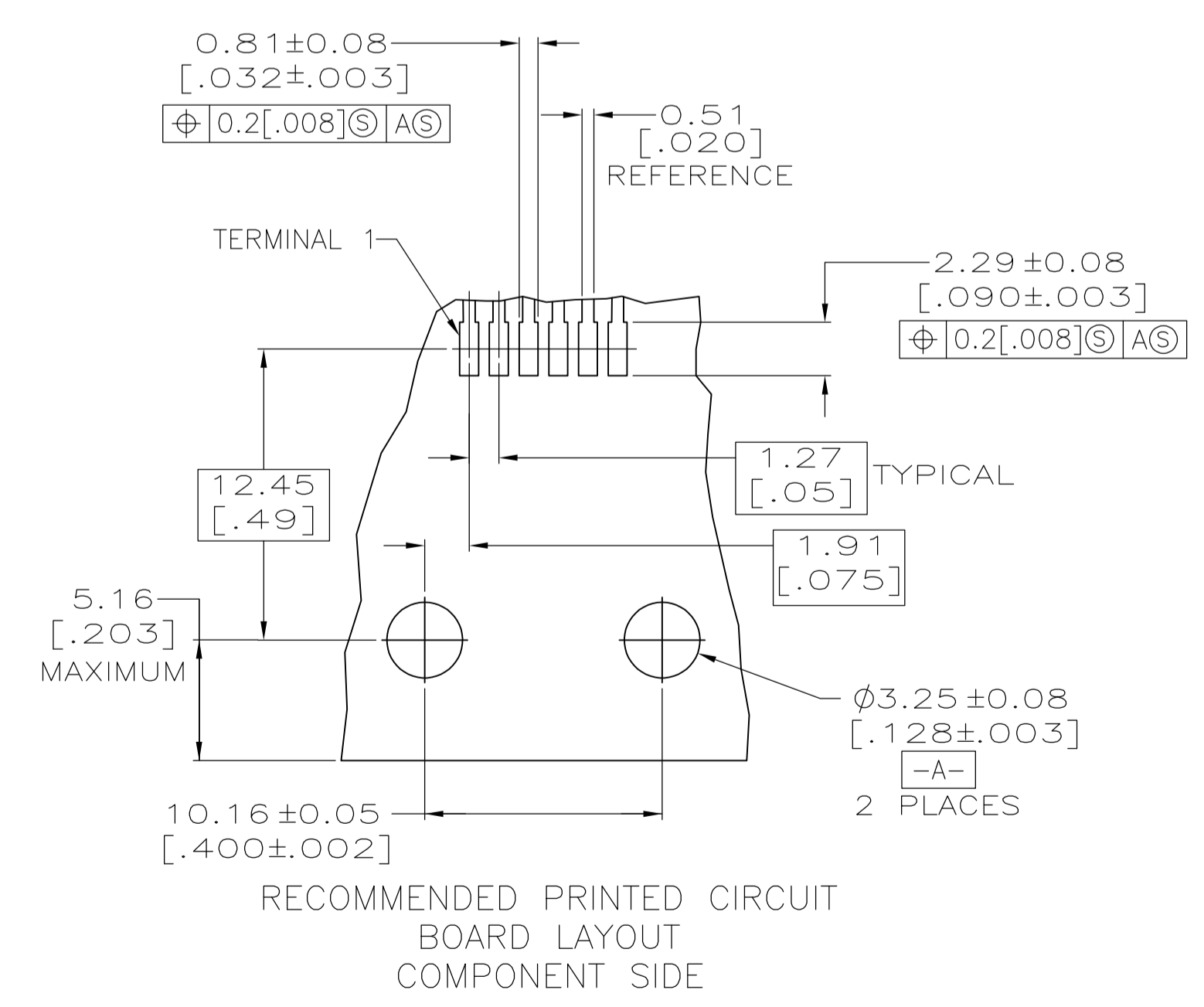

4	5555077-2
6	5555077-1
NUMBER OF TERMINALS	PART NUMBER

THIS DRAWING IS A CONTROLLED DOCUMENT.		DIN G. ATTADIA - 07JUN2005		TE Connectivity	
DIMENSIONS: mm [INCHES]		TOLERANCES UNLESS OTHERWISE SPECIFIED:		APVD S. FLICKINGER 07JUN2005	
0 PLC	± -	PRODUCT SPEC		NAME	
1 PLC	± -	108-1163		MODULAR JACK ASSEMBLY, 6 POSITION, LOW PROFILE, RIGHT ANGLE, SURFACE MOUNT W/ PANEL STOPS	
2 PLC	± -	APPLICATION SPEC		RESTRICTED TO	
3 PLC	± -	114-6040		SIZE	
4 PLC	± -	WEIGHT		SCALE	
ANGLES	± -	CUSTOMER DRAWING		SHEET 1 OF 1	
SEE NOTE 1	SEE NOTE 1	A1 00779 C=5555077		REV B1	