

**STRAIGHT BULKHEAD JACK FRONT MOUNT**

**CRIMP TYPE - CABLE 2.6/75 S**

**R142.306.500**

Series : BNC 75-COM

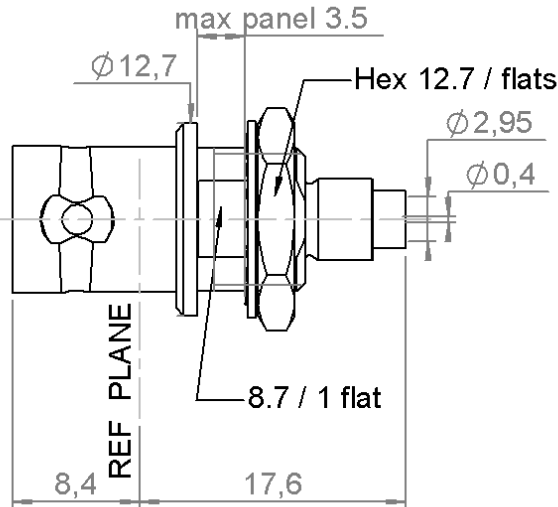

**PANEL CUT OUT**

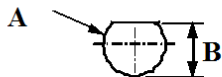

mm		
	Maxi	mini
<b>A</b>	9.6	9.5
<b>B</b>	8.85	8.75

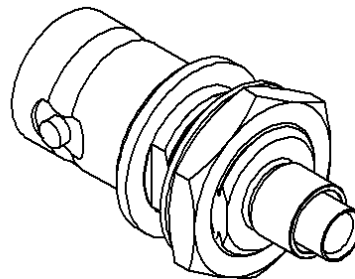
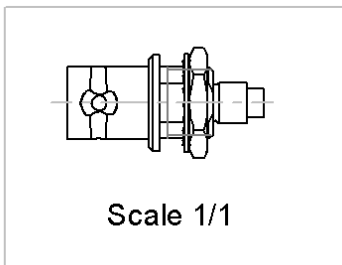

All dimensions are in mm.

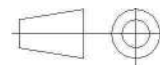

COMPONENTS	MATERIALS	PLATINGS (µm)
<b>BODY</b>	<b>BRASS</b>	<b>NICKEL 2</b>
<b>CENTER CONTACT</b>	<b>BERYLLIUM COPPER</b>	<b>GOLD 0.2 OVER NICKEL 2</b>
<b>OUTER CONTACT</b>	-	-
<b>INSULATOR</b>	<b>PTFE</b>	-
<b>GASKET</b>	-	-
<b>OTHERS PARTS</b>	<b>BRASS</b>	<b>NICKEL 2</b>
-	-	-
-	-	-

Issue : 1225 B

In the effort to improve our products, we reserve the right to make changes judged to be necessary.



**STRAIGHT BULKHEAD JACK FRONT MOUNT**

**R142.306.500**

**CRIMP TYPE - CABLE 2.6/75 S**

Series : **BNC 75-COM**

**PACKAGING**

Standard	Unit	Other
<b>100</b>	-	<b>Contact us</b>

**SPECIFICATION**

**ELECTRICAL CHARACTERISTICS**

Impedance		<b>75</b> Ω
Frequency		<b>0-1.5</b> GHz
VSWR	<b>NA</b> +	<b>0,0000</b> x F(GHz) Maxi
Insertion loss		<b>NA</b> √F(GHz) dB Maxi
RF leakage	- (	<b>NA</b> - F(GHz)) dB mini
Voltage rating		<b>335</b> Veff Maxi
Dielectric withstanding voltage		<b>1000</b> Veff mini
Insulation resistance		<b>5000</b> MΩ mini

**CABLE ASSEMBLY**

Stripping	a	b	c	d	e	f
mm	3,00	10,0	0,00	0,00	5,00	1,50

Assembly instruction :

Recommended cable(s)  
RG 179  
RG 187

Cable retention

- pull off **40** N mini  
- torque **NA** N.cm

**MECHANICAL CHARACTERISTICS**

Center contact retention		
Axial force – Mating end	<b>10</b>	N mini
Axial force – Opposite end	<b>10</b>	N mini
Torque	<b>NA</b>	N.cm mini

**TOOLING**

Part Number	Description	Hexagon
.	.	.
R282.223.000	CRIMPING TOOL	1.73
R282.235.011	CRIMPING DIES M22520/5-11	1.73
R282.211.000	CRIMPING TOOL	4.52
R282.293.000	CRIMPING TOOL M22520/5-01	-
R282.235.009	CRIMPING DIES M22520/5.09	4.52

Recommended torque		
Mating	<b>NA</b>	N.cm
Panel nut	<b>250</b>	N.cm
Clamp nut	<b>NA</b>	N.cm
A/F clamp nut	<b>0,0000</b>	mm

Mating life	<b>100</b>	Cycles mini
Weight	<b>6,6000</b>	g

**OTHERS CHARACTERISTICS**

**ENVIRONMENTAL**

Operating temperature	<b>-35/+70</b>	° C
Hermetic seal	<b>NA</b>	Atm.cm3/s
Panel leakage	<b>NA</b>	

Issue : **1225 B**

In the effort to improve our products, we reserve the right to make changes judged to be necessary.



**STRAIGHT BULKHEAD JACK FRONT MOUNT**

**R142.306.500**

Series : BNC 75-COM

**CRIMP TYPE - CABLE 2.6/75 S**

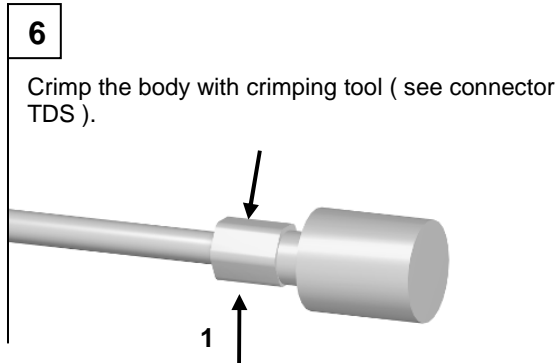
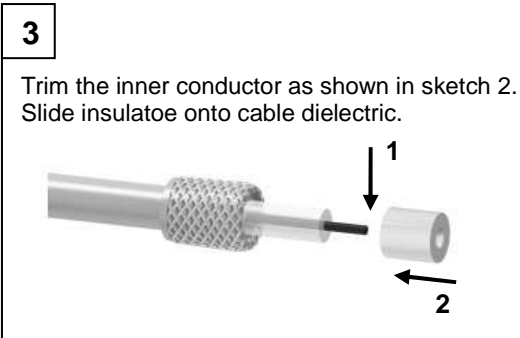
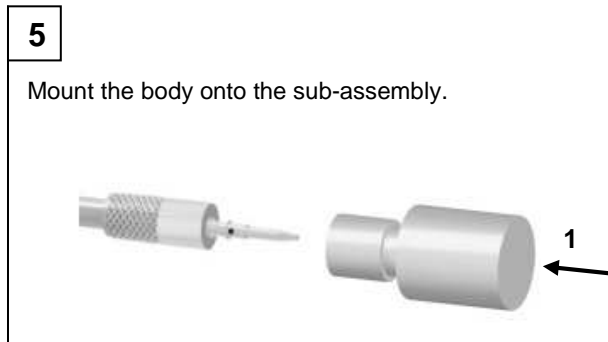
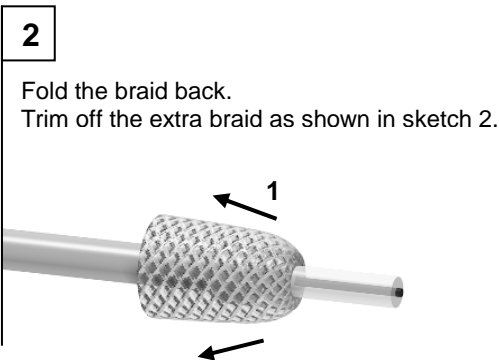
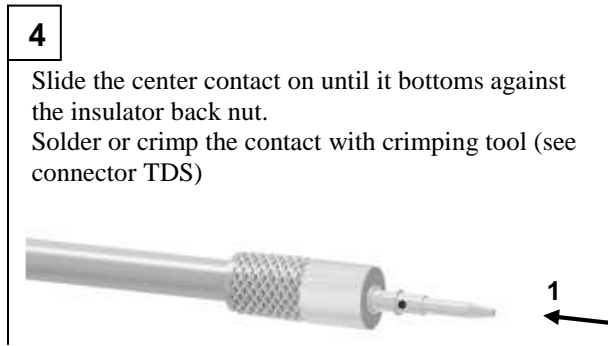
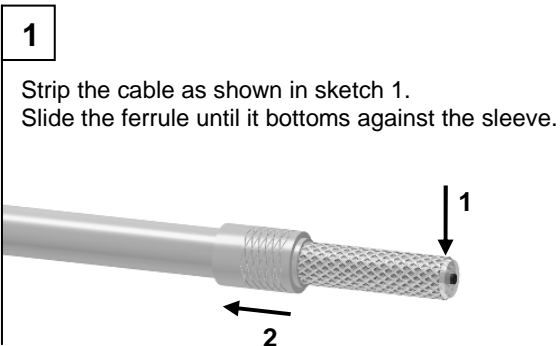
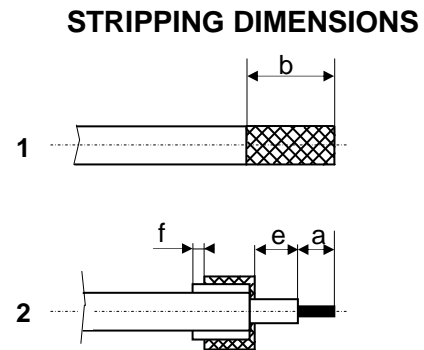
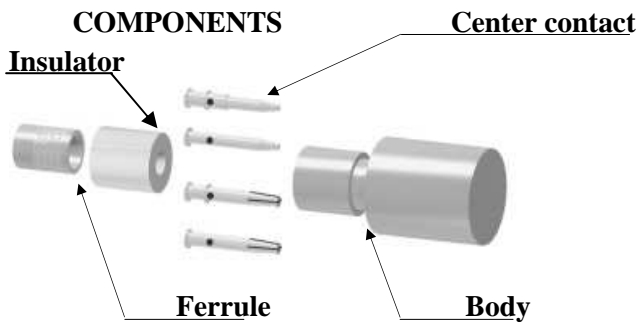

Issue : 1225 B

In the effort to improve our products, we reserve the right to make changes judged to be necessary.

