

UNCONTROLLED DOCUMENT

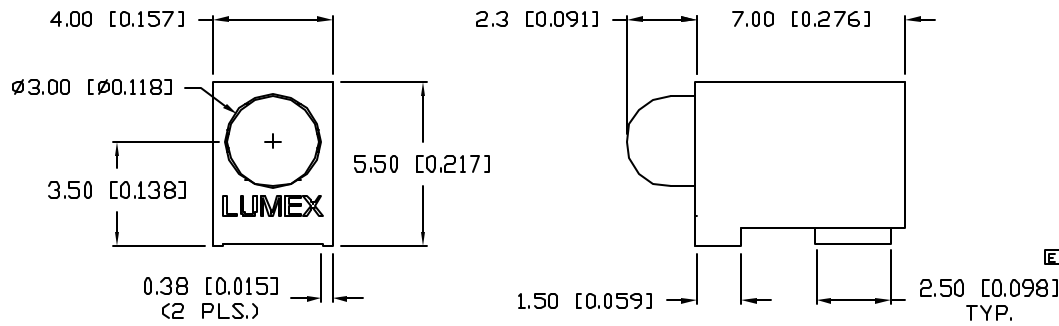

ANODE CATHODE

PATENT PENDING

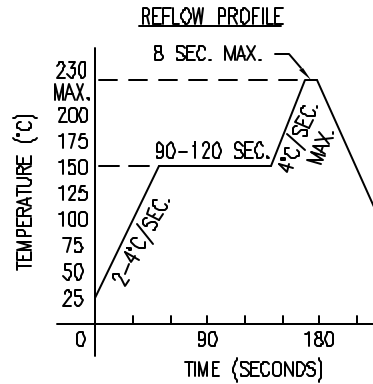
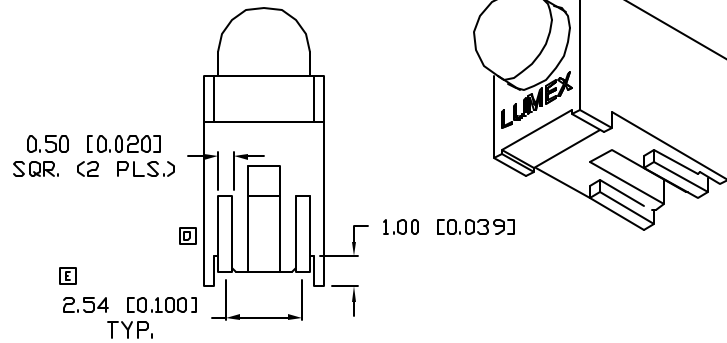

PART NUMBER		REV.
SSF-LXH305SYD(-TR)		F
REV.	E.C.N. NUMBER AND REVISION COMMENTS	DATE
A	E.C.N. #10BRDR & REDRAWN.	10.15.97
B	E.C.N. #10625.	5.19.00
C	E.C.N. #10683.	11.30.00
D	E.C.N. #10782.	11.6.01
E	E.C.N. #10855.	4.22.02
F	E.C.N. #10864.	5.15.02

ELECTRO-OPTICAL CHARACTERISTICS $T_A=25^\circ\text{C}$ $I_f=20\text{mA}$

PARAMETER	MIN	TYP	MAX	UNITS	TEST COND
PEAK WAVELENGTH		590		nm	
FORWARD VOLTAGE		2.0	2.5	V _f	
REVERSE VOLTAGE	5.0			V _r	$I_f=100\mu\text{A}$
AXIAL INTENSITY		250		mcd	$I_f=20\text{mA}$
VIEWING ANGLE		60		2x theta	
EMITTED COLOR:	YELLOW				
EPOXY LENS FINISH:	YELLOW DIFFUSED				

LIMITS OF SAFE OPERATION AT 25°C

PARAMETER	MAX	UNITS
PEAK FORWARD CURRENT*	150	mA
STEADY CURRENT	30	mA
POWER DISSIPATION	105	mW
DERATE FROM 25°C	-1.6	mW/°C
OPERATING, STORAGE TEMP.	-40 TO +85	°C
SOLDERING TEMP.	+230	°C
		3 SEC. MAX

* $t < 10\mu\text{s}$

NOTES:

1. SSL-LX305F4SYD, YELLOW LED.
2. SSH-LXH305, BLACK HOLDER.
3. -TR SUFFIX TO DESIGNATE TAPE AND REEL SUPPLIED.
4. CARRIER TAPE #LXP-CARRIER24-56.

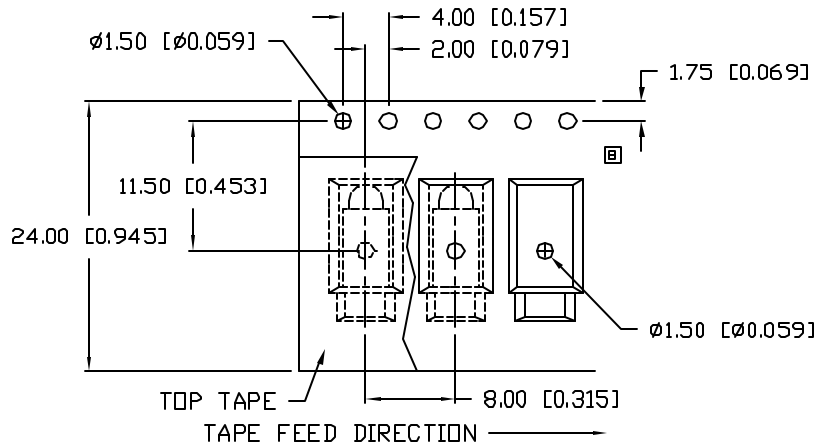

RECOMMENDED SOLDER PAD LAYOUT

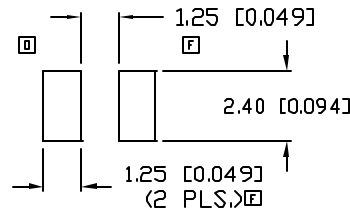

*UNLESS OTHERWISE SPECIFIED TOLERANCES PER DECIMAL PRECISION ARE: X=±1 (±0.039), XX=±0.5 (±0.020), XXX=±0.25 (±0.010), XXXX=±0.127 (±0.005), LEAD SIZE=±0.05 (±0.002), LEAD LENGTH=±0.75 (±0.030), MIN.=+DECIMAL PRECISION -0.00, MAX.=+0.00 -DECIMAL PRECISION

UNCONTROLLED DOCUMENT

REV.	PART NUMBER
F	SSF-LXH305SYD(-TR)
T-3mm (T-1) RIGHT ANGLE SURFACE MOUNT LED, 590nm SUPER YELLOW LED, YELLOW DIFFUSED LENS, TAPE AND REEL.	

CONFIDENTIAL INFORMATION

THE INFORMATION CONTAINED IN THIS DOCUMENT IS THE PROPERTY OF LUMEX INC. EXCEPT AS SPECIFICALLY AUTHORIZED IN WRITING BY LUMEX INC., THE HOLDER OF THIS DOCUMENT SHALL KEEP ALL INFORMATION CONTAINED HEREIN CONFIDENTIAL AND SHALL PROTECT SAME IN WHOLE OR IN PART FROM DISCLOSURE AND DISSEMINATION TO ALL THIRD PARTIES.

RELIABILITY NOTE

OUR MANY YEARS OF EXPERIENCE DATA ACCUMULATION INDICATE THAT SOLDER HEAT IS A MAJOR CAUSE OF EARLY AND FUTURE FAILURE. PLEASE PAY ATTENTION TO YOUR SOLDERING PROCESS.

		290 E. HELEN ROAD PALATINE, IL 60067-6976 PHONE: +1.847.359.2790 US WEB: www.lumex.com TW WEB: www.lumex.com.tw
DRAWN BY:	CHECKED BY:	APPROVED BY:
BC		
DATE: 10.10.97		PAGE: 1 OF 1
SCALE: N/A		