

Single Phase Rectifier Bridge

$I_{dAV} = 53 \text{ A}$
 $V_{RRM} = 800-1600 \text{ V}$

Preliminary data

V_{RSM} V_{DSM} V	V_{RRM} V_{DRM} V	Type
800	800	xxx 55-08io7
1200	1200	xxx 55-12io7
1400	1400	xxx 55-14io7
1600	1600	xxx 55-16io7
xxx = type		

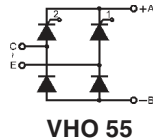

VHO 55

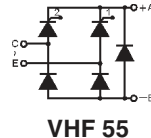

VHF 55

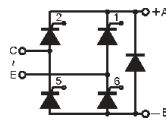

VKF 55

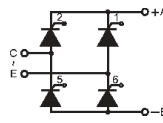

VKO 55

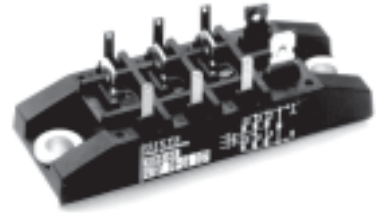

Symbol	Test Conditions	Maximum Ratings	Features
I_{dAV} ①	$T_K = 85^\circ\text{C}$, module	53 A	<ul style="list-style-type: none"> • Package with copper base plate • Isolation voltage 3000 V~ • Planar passivated chips • Low forward voltage drop • 1/4" fast-on power terminals
I_{dAVM} ①	module	53 A	
I_{FRMS} , I_{TRMS}	per leg	41 A	
I_{FSM} , I_{TSM}	$T_{VJ} = 45^\circ\text{C}$; $V_R = 0 \text{ V}$	$t = 10 \text{ ms}$ (50 Hz), sine $t = 8.3 \text{ ms}$ (60 Hz), sine	550 A 600 A
	$T_{VJ} = T_{VJM}$ $V_R = 0 \text{ V}$	$t = 10 \text{ ms}$ (50 Hz), sine $t = 8.3 \text{ ms}$ (60 Hz), sine	500 A 550 A
I^2t	$T_{VJ} = 45^\circ\text{C}$ $V_R = 0 \text{ V}$	$t = 10 \text{ ms}$ (50 Hz), sine $t = 8.3 \text{ ms}$ (60 Hz), sine	1520 A ² s 1520 A ² s
	$T_{VJ} = T_{VJM}$ $V_R = 0 \text{ V}$	$t = 10 \text{ ms}$ (50 Hz), sine $t = 8.3 \text{ ms}$ (60 Hz), sine	1250 A ² s 1250 A ² s
$(di/dt)_{cr}$	$T_{VJ} = 125^\circ\text{C}$ $f = 50 \text{ Hz}$, $t_p = 200 \mu\text{s}$ $V_D = 2/3 V_{DRM}$ $I_G = 0.3 \text{ A}$, $di_G/dt = 0.3 \text{ A}/\mu\text{s}$	repetitive, $I_T = 50 \text{ A}$	150 A/ μs
		non repetitive, $I_T = 1/2 \cdot I_{dAV}$	500 A/ μs
$(dv/dt)_{cr}$	$T_{VJ} = T_{VJM}$; $V_{DR} = 2/3 V_{DRM}$ $R_{GK} = \infty$; method 1 (linear voltage rise)		1000 V/ μs
V_{RGM}			10 V
P_{GM}	$T_{VJ} = T_{VJM}$ $I_T = I_{TAVM}$	$t_p = 30 \mu\text{s}$	$\leq 10 \text{ W}$
		$t_p = 500 \mu\text{s}$	$\leq 5 \text{ W}$
		$t_p = 10 \text{ ms}$	$\leq 1 \text{ W}$
P_{GAVM}			0.5 W
T_{VJ}			-40...+125 °C
T_{VJM}			125 °C
T_{stg}			-40...+125 °C
V_{ISOL}	50/60 Hz, RMS $I_{ISOL} \leq 1 \text{ mA}$	$t = 1 \text{ min}$	2500 V~
		$t = 1 \text{ s}$	3000 V~
M_d	Mounting torque (M5) (10-32 UNF)		$5 \pm 15 \%$ Nm
			$44 \pm 15 \%$ lb.in.
Weight			110 g

Applications

- Supplies for DC power equipment
- Input rectifiers for PWM inverter
- Battery DC power supplies
- Field supply for DC motors

Advantages

- Easy to mount with two screws
- Space and weight savings
- Improved temperature and power cycling capability
- Small and light weight

Dimensions in mm (1 mm = 0.0394")

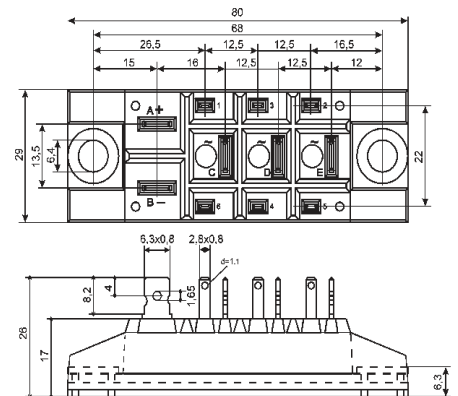

Data according to IEC 60747 refer to a single diode/thyristor unless otherwise stated
① for resistive load at bridge output.

IXYS reserves the right to change limits, test conditions and dimensions.

20070731a

Symbol	Test Conditions	Characteristic Values	
I_D, I_R	$T_{VJ} = T_{VJM}; V_R = V_{RRM}; V_D = V_{DRM}$	\leq	5 mA
V_T	$I_T = 80 \text{ A}; T_{VJ} = 25^\circ\text{C}$	\leq	1.64 V
V_{T0}	For power-loss calculations only		0.85 V
r_T			11 m Ω
V_{GT}	$V_D = 6 \text{ V}; T_{VJ} = 25^\circ\text{C}$	\leq	1.5 V
	$T_{VJ} = -40^\circ\text{C}$	\leq	1.6 V
I_{GT}	$V_D = 6 \text{ V}; T_{VJ} = 25^\circ\text{C}$	\leq	100 mA
	$T_{VJ} = -40^\circ\text{C}$	\leq	200 mA
V_{GD}	$T_{VJ} = T_{VJM}; V_D = 2/3 V_{DRM}$	\leq	0.2 V
I_{GD}		\leq	5 mA
I_L	$T_{VJ} = 25^\circ\text{C}; t_p = 10 \mu\text{s}$ $I_G = 0.45 \text{ A}; di_G/dt = 0.45 \text{ A}/\mu\text{s}$	\leq	450 mA
I_H	$T_{VJ} = 25^\circ\text{C}; V_D = 6 \text{ V}; R_{GK} = \infty$	\leq	200 mA
t_{gd}	$T_{VJ} = 25^\circ\text{C}; V_D = 1/2 V_{DRM}$ $I_G = 0.45 \text{ A}; di_G/dt = 0.45 \text{ A}/\mu\text{s}$	\leq	2 μs
t_q	$T_{VJ} = T_{VJM}; I_T = 20 \text{ A}, t_p = 200 \mu\text{s}; di/dt = -10 \text{ A}/\mu\text{s}$ typ. $V_R = 100 \text{ V}; dv/dt = 15 \text{ V}/\mu\text{s}; V_D = 2/3 V_{DRM}$		250 μs
R_{thJC}	per thyristor / Diode; DC		0.9 K/W
	per module		0.18 K/W
R_{thJK}	per thyristor / Diode; DC		1.1 K/W
	per module		0.22 K/W
d_s	Creeping distance on surface		16.1 mm
d_A	Creepage distance in air		7.1 mm
a	Max. allowable acceleration		50 m/s ²

PHASE-OUT