

## 600MHz, Very High Slew Rate Operational Amplifier

November 1996

### Features

- **Very High Slew Rate** ..... 600V/ $\mu$ s
- **Open Loop Gain** ..... 15kV/V
- **Wide Gain-Bandwidth ( $A_V \geq 10$ )** ..... 600MHz
- **Power Bandwidth** ..... 9.5MHz
- **Low Offset Voltage** ..... 8mV
- **Input Voltage Noise** ..... 6nV/ $\sqrt{\text{Hz}}$
- **Output Voltage Swing** .....  $\pm 10\text{V}$
- **Monolithic Bipolar Dielectric Construction**

### Applications

- **Pulse and Video Amplifiers**
- **Wideband Amplifiers**
- **High Speed Sample-Hold Circuits**
- **RF Oscillators**

### Ordering Information

PART NUMBER	TEMP. RANGE ( $^{\circ}\text{C}$ )	PACKAGE	PKG. NO.
HA1-2539-2	-55 to 125	14 Ld CERDIP	F14.3
HA1-2539-5	0 to 75	14 Ld CERDIP	F14.3
HA3-2539-5	0 to 75	14 Ld PDIP	E14.3
HA3-2539C-5	0 to 75	14 Ld PDIP	E14.3
HA9P2539-5	0 to 75	14 Ld SOIC	M14.15
HA9P2539-9	-40 to 85	14 Ld SOIC	M14.15

### Description

The Harris HA-2539 represents the ultimate in high slew rate, wideband, monolithic operational amplifiers. It has been designed and constructed with the Harris High Frequency Bipolar Dielectric Isolation process and features dynamic parameters never before available from a truly differential device.

With a 600V/ $\mu$ s slew rate and a 600MHz gain bandwidth product, the HA-2539 is ideally suited for use in video and RF amplifier designs, in closed loop gains of 10 or greater. Full  $\pm 10\text{V}$  swing coupled with outstanding AC parameters and complemented by high open loop gain makes the devices useful in high speed data acquisition systems.

For further design assistance please refer to Application Note AN541 (Using the HA-2539 Very High Slew Rate Wideband Operational Amplifiers) and Application Note AN556 (Thermal Safe-Operating-Areas For High Current Operational Amplifiers).

For military grade product information, the HA-2539/883 data sheet is available upon request.

For a lower power version of this product, please see the HA-2839 and HA-2840 data sheets.

3  
OPERATIONAL AMPLIFIERS

### Pinout

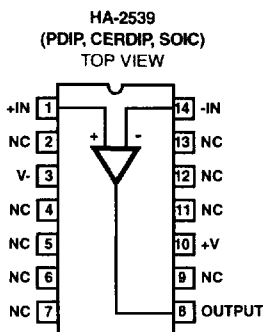

# HA-2539

## Absolute Maximum Ratings

Supply Voltage Between V+ and V- Terminals	35V
Differential Input Voltage	6V
Peak Output Current	50mA
Continuous Output Current	33mA <sub>RMS</sub>

## Operating Conditions

Temperature Range	
HA-2539-2	-55°C to 125°C
HA-2539/2539C-5	0°C to 75°C
HA-2539-9	-40°C to 85°C

## Thermal Information

Thermal Resistance (Typical, Note 2)	$\theta_{JA}$ (°C/W)	$\theta_{JC}$ (°C/W)
CERDIP Package	75	20
PDIP Package	107	N/A
SOIC Package	119	N/A

### Maximum Internal Quiescent Power Dissipation (Note 1)

Maximum Junction Temperature (Ceramic Package)	175°C
Maximum Junction Temperature (Plastic Packages)	150°C
Maximum Storage Temperature Range	-65°C to 150°C
Maximum Lead Temperature (Soldering 10s) (SOIC - Lead Tips Only)	300°C

CAUTION: Stresses above those listed in "Absolute Maximum Ratings" may cause permanent damage to the device. This is a stress only rating and operation of the device at these or any other conditions above those indicated in the operational sections of this specification is not implied.

## NOTES:

- Maximum power dissipation with load conditions must be designed to maintain the maximum junction temperature below 175°C for the ceramic package and below 150°C for the plastic packages. By using Application Note AN556 on Safe Operating Area equations, along with the thermal resistances, proper load conditions can be determined. Heat sinking is recommended above 75°C.
- $\theta_{JA}$  is measured with the component mounted on an evaluation PC board in free air.

## Electrical Specifications $V_{SUPPLY} = \pm 15V, R_L = 1k\Omega, C_L < 10pF$ , Unless Otherwise Specified

PARAMETER	TEMP. (°C)	HA-2539-2			HA-2539-5, -9			HA-2539C-5			UNITS
		MIN	TYP	MAX	MIN	TYP	MAX	MIN	TYP	MAX	
<b>INPUT CHARACTERISTICS</b>											
Offset Voltage	25	-	8	10	-	8	15	-	8	15	mV
	Full	-	13	15	-	13	20	-	13	20	mV
Average Offset Voltage Drift	Full	-	20	-	-	20	-	-	20	-	$\mu V/^\circ C$
Bias Current	25	-	5	20	-	5	20	-	5	20	$\mu A$
	Full	-	-	25	-	-	25	-	-	25	$\mu A$
Offset Current	25	-	1	6	-	1	6	-	1	6	$\mu A$
	Full	-	-	8	-	-	8	-	-	8	$\mu A$
Input Resistance	25	-	10	-	-	10	-	-	10	-	k $\Omega$
Input Capacitance	25	-	1	-	-	1	-	-	1	-	pF
Common Mode Range	Full	$\pm 10.0$	-	-	$\pm 10.0$	-	-	$\pm 10.0$	-	-	V
Input Current Noise (f = 1kHz, $R_{SOURCE} = 0\Omega$ )	25	-	6	-	-	6	-	-	6	-	pA $\sqrt{Hz}$
Input Voltage Noise (f = 1kHz, $R_{SOURCE} = 0\Omega$ )	25	-	6	-	-	6	-	-	6	-	nV $\sqrt{Hz}$
<b>TRANSFER CHARACTERISTICS</b>											
Large Signal Voltage Gain (Note 3)	25	10	15	-	10	15	-	7	10	-	kV/V
	Full	5	-	-	5	-	--	5	-	-	kV/V
Common Mode Rejection Ratio (Note 4)	Full	60	72	-	60	72	-	60	72	-	dB
Minimum Stable Gain	25	10	-	-	10	-	-	10	-	-	V/V
Gain Bandwidth (Notes 5, 6)	25	-	600	-	-	600	-	-	600	-	MHz
<b>OUTPUT CHARACTERISTICS</b>											
Output Voltage Swing (Notes 3, 10)	Full	$\pm 10.0$	-	-	$\pm 10.0$	-	-	$\pm 10.0$	-	-	V
Output Current (Note 3)	25	$\pm 10$	$\pm 20$	-	$\pm 10$	$\pm 20$	-	$\pm 10$	$\pm 20$	-	mA
Output Resistance	25	-	30	-	-	30	-	-	30	-	$\Omega$
Full Power Bandwidth (Notes 3, 7)	25	8.7	9.5	-	8.7	9.5	-	8.7	9.5	-	MHz

# HA-2539

## Electrical Specifications $V_{SUPPLY} = \pm 15V, R_L = 1k\Omega, C_L < 10pF$ . Unless Otherwise Specified (Continued)

PARAMETER	TEMP. (°C)	HA-2539-2			HA-2539-5, -9			HA-2539C-5			UNITS
		MIN	TYP	MAX	MIN	TYP	MAX	MIN	TYP	MAX	
<b>TRANSIENT RESPONSE</b> (Note 8)											
Rise Time	25	-	7	-	-	7	-	-	7	-	ns
Overshoot	25	-	15	-	-	15	-	-	15	-	%
Slew Rate	25	550	600	-	550	600	-	550	600	-	V/ $\mu$ s
Settling Time, 10V Step to 0.1%	25	-	180	-	-	180	-	-	200	-	ns
<b>POWER REQUIREMENTS</b>											
Supply Current	Full	-	20	25	-	20	25	-	20	25	mA
Power Supply Rejection Ratio (Note 9)	Full	60	70	-	60	70	-	60	70	-	dB

**NOTES:**

3.  $R_L = 1k\Omega, V_O = \pm 10V$ .
4.  $V_{CM} = \pm 10.0V$ .
5.  $V_O = 90mV$
6.  $A_V = 10$ .
7. Full Power Bandwidth guaranteed based on slew rate measurement using:  $FPBW = \frac{\text{Slew Rate}}{2\pi V_{PEAK}}$ .
8. Refer to Test Circuits section of data sheet.
9.  $V_{SUPPLY} = +5V, -15V$  and  $+15V, -5V$ .
10. Guaranteed range for output voltage is  $\pm 10V$ . Functional operation outside of this range is not guaranteed.

**3**  
**OPERATIONAL AMPLIFIERS**

## Test Circuits and Waveforms

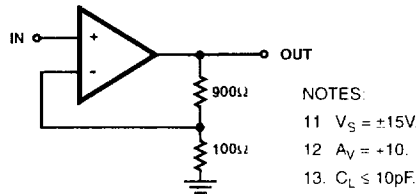
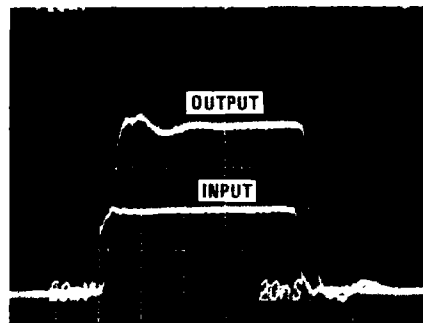

**FIGURE 1. TEST CIRCUIT**



Vertical Scale: A = 0.5V/Div., B = 5.0V/Div.  
Horizontal Scale: 50ns/Div.

**FIGURE 2. LARGE SIGNAL RESPONSE**



Vertical Scale: Input = 10mV/Div., Output = 50mV/Div.  
Horizontal Scale: 20ns/Div.

**FIGURE 3. SMALL SIGNAL RESPONSE**

**Test Circuits and Waveforms** (Continued)

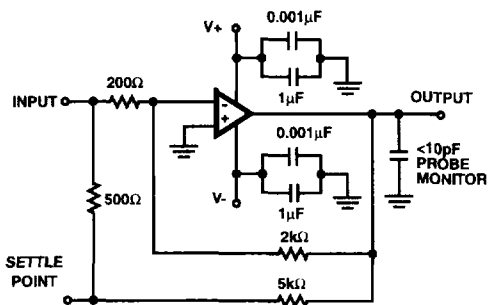

NOTES:

- 14.  $A_v = -10$ .
- 15. Load Capacitance should be less than 10pF.
- 16. It is recommended that resistors be carbon composition and that feedback and summing network ratios be matched to 0.1%.
- 17. SETTLE POINT (Summing Node) capacitance should be less than 10pF. For optimum settling time results, it is recommended that the test circuit be constructed directly onto the device pins. A Tektronix 568 Sampling Oscilloscope with S-3A sampling heads is recommended as a settle point monitor.

FIGURE 4. SETTLING TIME CIRCUIT

**Schematic Diagram**

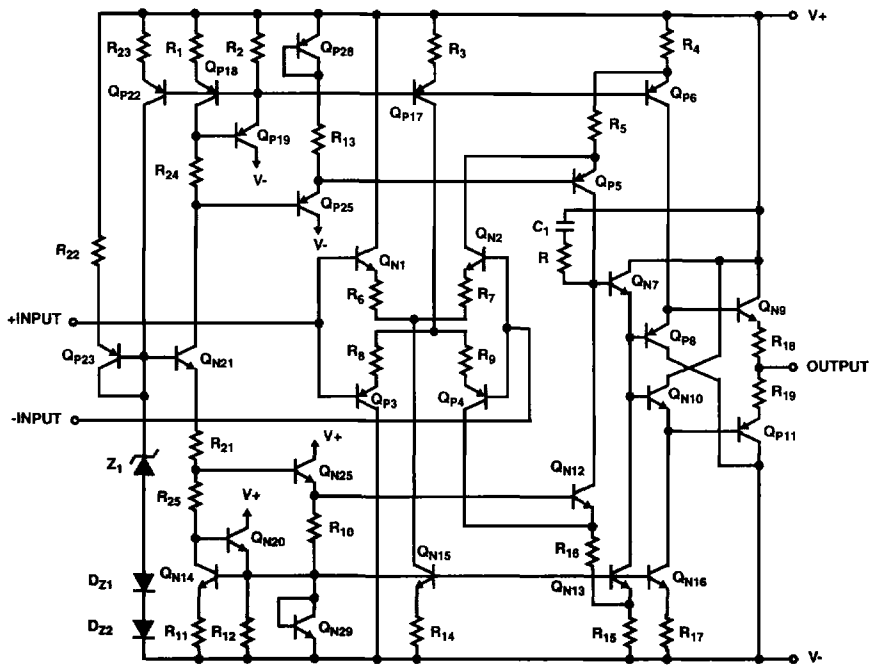

Typical Applications

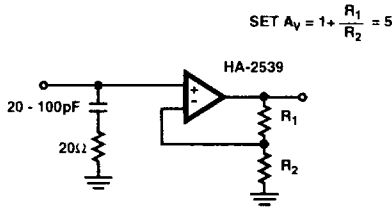

FIGURE 5. FREQUENCY COMPENSATION BY OVERDAMPING

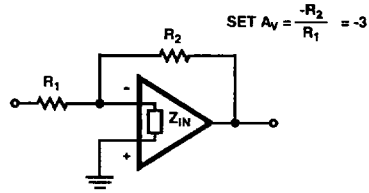

FIGURE 6. STABILIZATION USING  $Z_{IN}$

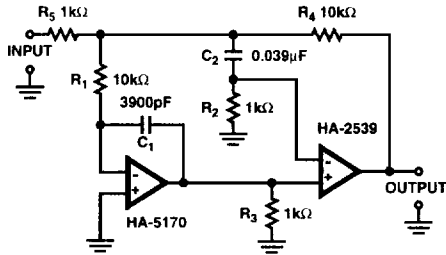

FIGURE 7. REDUCING DC ERRORS; COMPOSITE AMPLIFIER

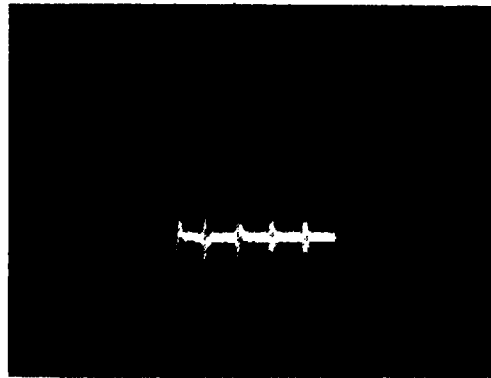

FIGURE 8. DIFFERENTIAL GAIN ERROR (3%) HA-2539 20dB VIDEO GAIN BLOCK

**3**

OPERATIONAL AMPLIFIERS

Typical Performance Curves

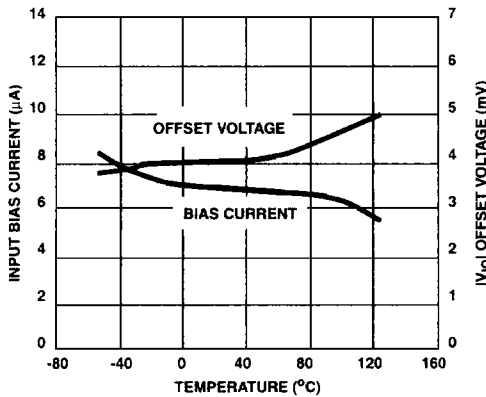

FIGURE 9. INPUT OFFSET VOLTAGE AND BIAS CURRENT vs TEMPERATURE

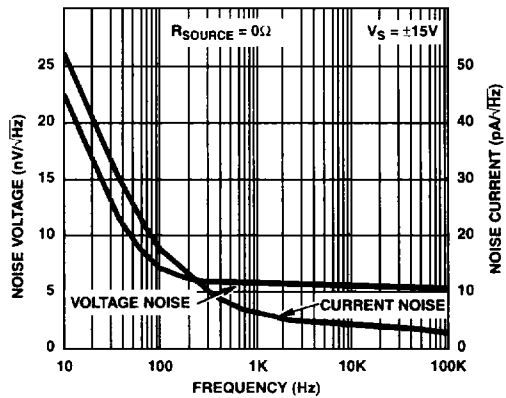

FIGURE 10. INPUT NOISE VOLTAGE AND NOISE CURRENT vs FREQUENCY

Typical Performance Curves (Continued)

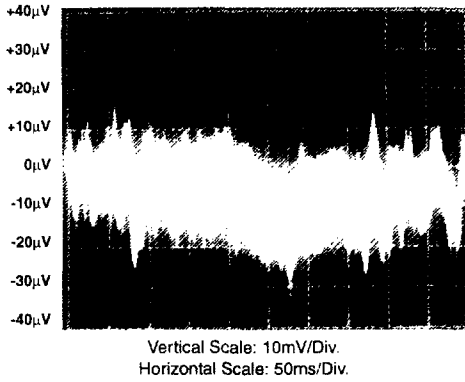

FIGURE 11. BROADBAND NOISE (0.1Hz TO 1MHz)

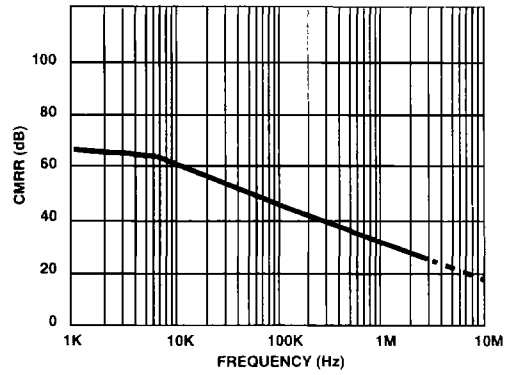

FIGURE 12. COMMON MODE REJECTION RATIO vs FREQUENCY

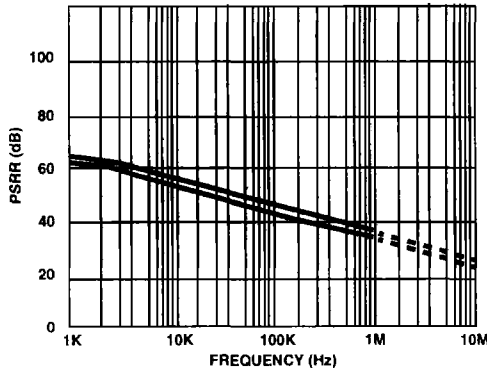

FIGURE 13. POWER SUPPLY REJECTION RATIO vs FREQUENCY

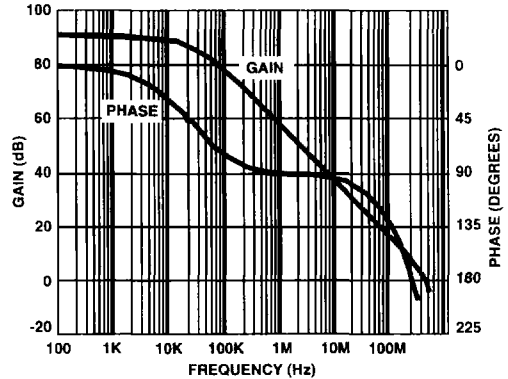

FIGURE 14. OPEN LOOP GAIN/PHASE vs FREQUENCY

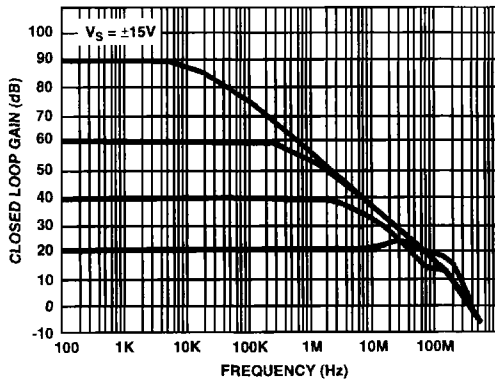

FIGURE 15. CLOSED LOOP FREQUENCY RESPONSE

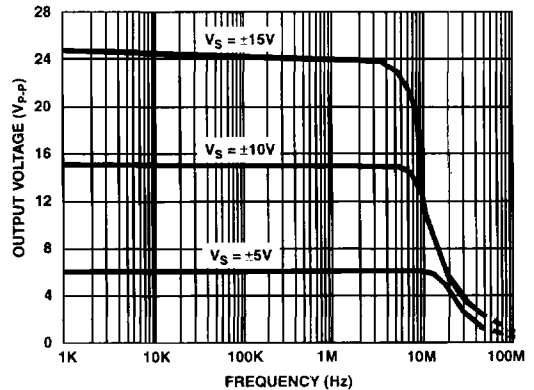

FIGURE 16. OUTPUT VOLTAGE SWING vs FREQUENCY

Typical Performance Curves (Continued)

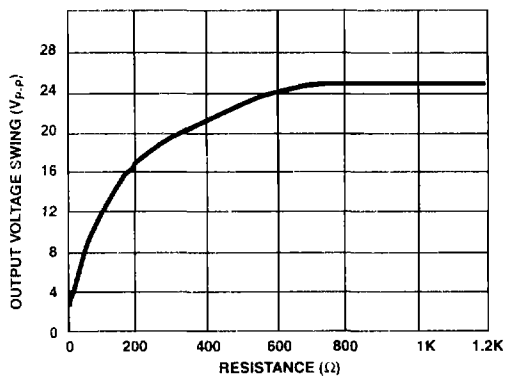

FIGURE 17. OUTPUT VOLTAGE SWING vs LOAD RESISTANCE

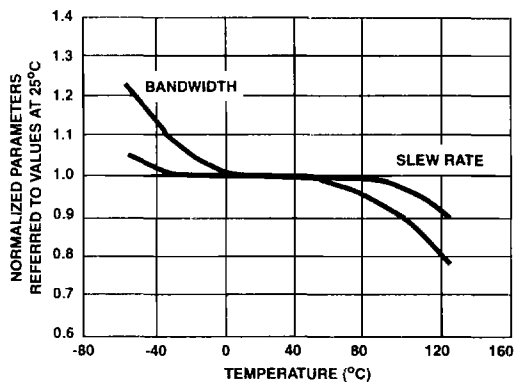

FIGURE 18. NORMALIZED AC PARAMETERS vs TEMPERATURE

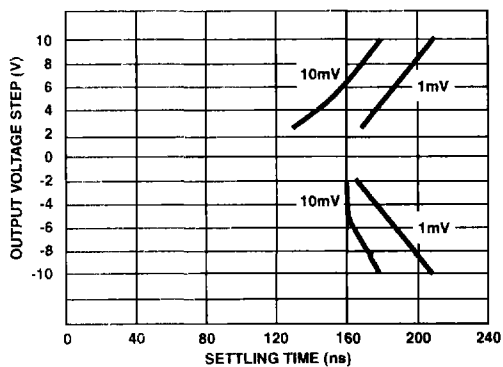

FIGURE 19. SETTLING TIME FOR VARIOUS OUTPUT STEP VOLTAGES

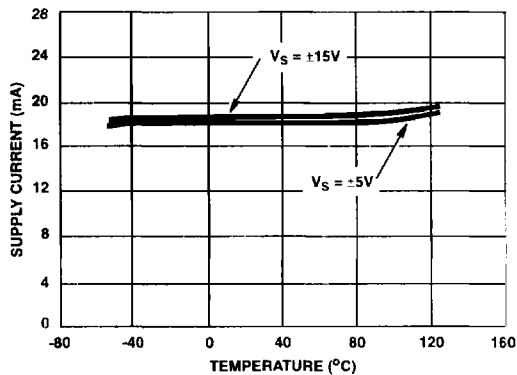

FIGURE 20. POWER SUPPLY CURRENT vs TEMPERATURE

# HA-2539

## Die Characteristics

### DIE DIMENSIONS:

62 mils x 76 mils x 19 mils  
1575 $\mu$ m x 1930 $\mu$ m x 483 $\mu$ m

### METALLIZATION:

Type: Al, 1% Cu  
Thickness: 16k $\text{\AA}$   $\pm$  2k $\text{\AA}$

### PASSIVATION:

Type: Nitride (Si<sub>3</sub>N<sub>4</sub>) over Silox (SiO<sub>2</sub>, 5% Phos.)  
Silox Thickness: 12k $\text{\AA}$   $\pm$  2k $\text{\AA}$   
Nitride Thickness: 3.5k $\text{\AA}$   $\pm$  1.5k $\text{\AA}$

### SUBSTRATE POTENTIAL (Powered Up):

V-

### TRANSISTOR COUNT:

30

### PROCESS:

Bipolar Dielectric Isolation

## Metallization Mask Layout

