

P	LTR	DESCRIPTION	DATE	DWN	APVD
	E	REVISED PER ECR-23-175984	30MAY2023	BB	DSC

3 STRIPES EQUALLY SPACED
COLOR CODE: RED

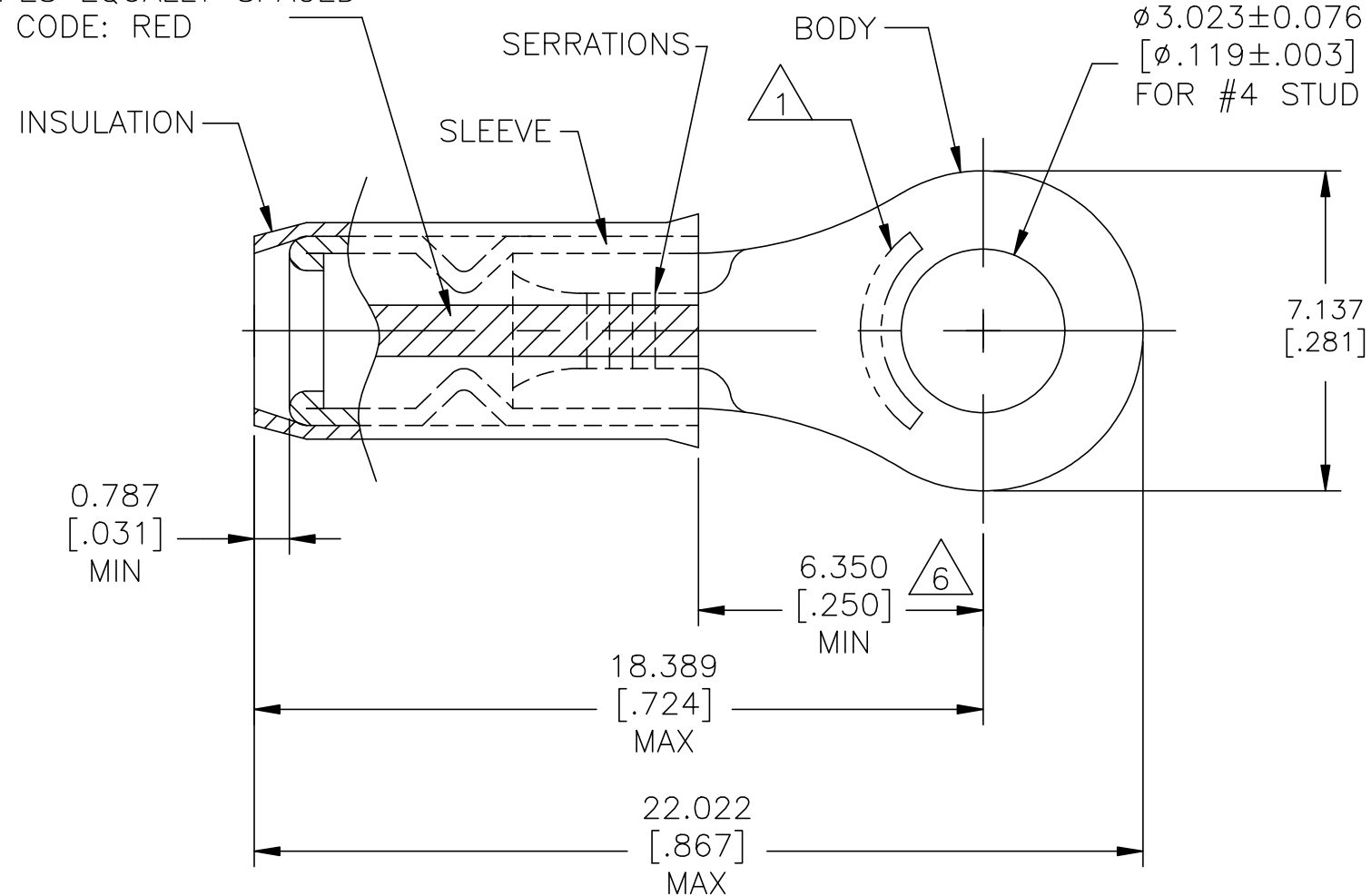

- 1. STAMP "AMP 22-18*" APPROX AS SHOWN
- 2. WIRE INSULATION DIAMETER:
Ø1.250[.049] TO Ø1.770[.070]
- 3. BODY MATERIAL THK: 0.787±0.051[.031±.002]
- 4. MATERIAL:
BODY & SLEEVE - COPPER PER ASTM B152
INSULATION - NYLON
- 5. FINISH:
BODY & SLEEVE - TIN PLATE 0.00254[.000100]
MIN EXT THK PER ASTM B545
INSULATION COLOR - RED
- 6. APPLIES FROM EDGE OF METAL WIRE BARREL TO
CENTER OF STUD HOLE

1000	LOOSE PIECE	131644-1
QTY	PACKAGE TYPE	PART NUMBER

AMP INCORPORATED CUSTOMER SERVICE SYSTEMS	
FOR ADDITIONAL PRODUCT INFORMATION OR COPIES OF DRAWINGS AND TECHNICAL DOCUMENTS	PRODUCT INFORMATION CENTER 1-800-522-6752
FOR APPLICATION TOOLING INFORMATION	TOOLING ASSISTANCE CENTER 1-800-722-1111
FOR ORDER ENTRY	1-800-526-5142

MAX RECOMMENDED OPERATING TEMPERATURE: 105°C [221°F] MAX
VOLTAGE RATING: 300 V MAX
WIRE RANGE: CIRC MIL AREA: 20 0.60mm ² [1,186] STRANDED

THIS DRAWING IS A CONTROLLED DOCUMENT.	
DIMENSIONS: mm [INCHES]	TOLERANCES UNLESS OTHERWISE SPECIFIED:
	0 PLC ± - 1 PLC ± - 2 PLC ± - 3 PLC ± 0.127[.005] 4 PLC ± - ANGLES ± -
MATERIAL	FINISH
4	5

DWN	12MAY2023
LINGANATHAN P	
CHK	12MAY2023
SUVARNA, CHETHAN D	
APVD	12MAY2023
SUVARNA, CHETHAN D	
PRODUCT SPEC	
APPLICATION SPEC	
114-2157	
WEIGHT	-
CUSTOMER DRAWING	

TE TE Connectivity			
NAME TERMINAL, RING TONGUE, IR, PIDG™ WIRE SIZE: 20 AWG			
SIZE	CAGE CODE	DRAWING NO	RESTRICTED TO
A3	00779	131644	-
SCALE		SHEET	REV
NTS		1 of 1	E