

LOC	DIST	REV	DESCRIPTION	DATE	DWN	APVD
FT	0	D5	EDITED NOTES PER ECO-11-013836	15JUL2011	DW	JE

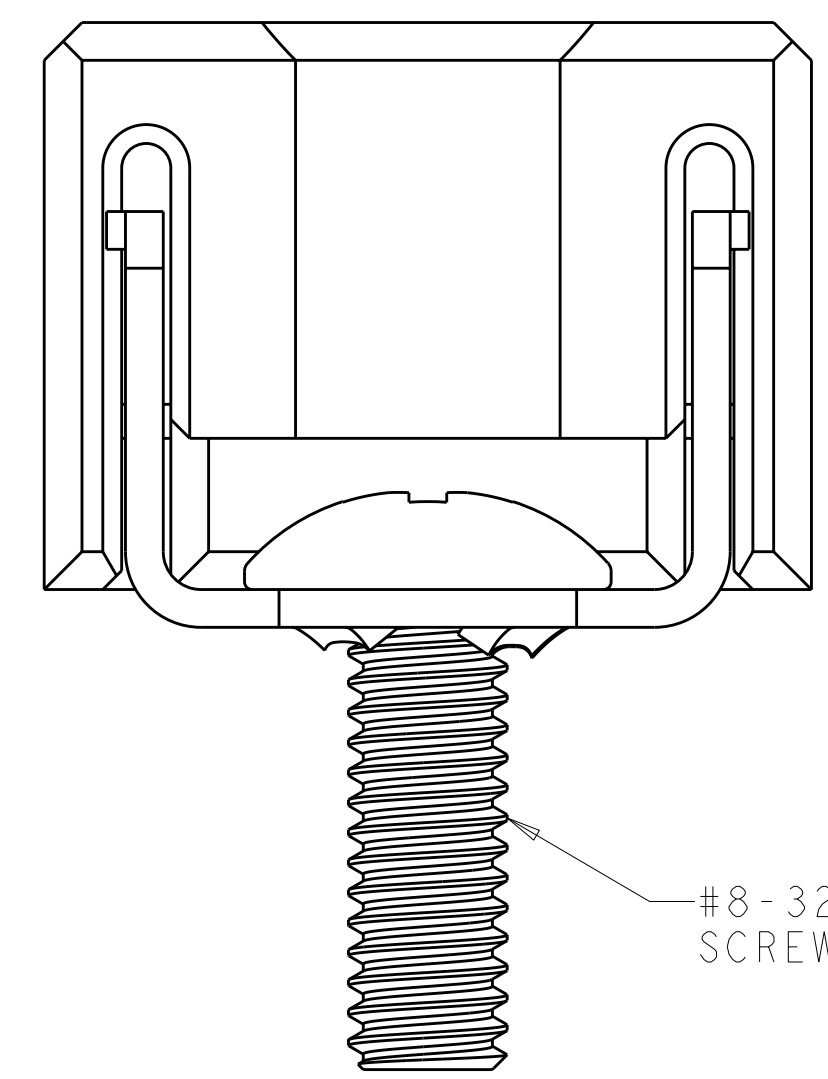

#8-32 PAN HEAD SCREW

1954381-2 & -3

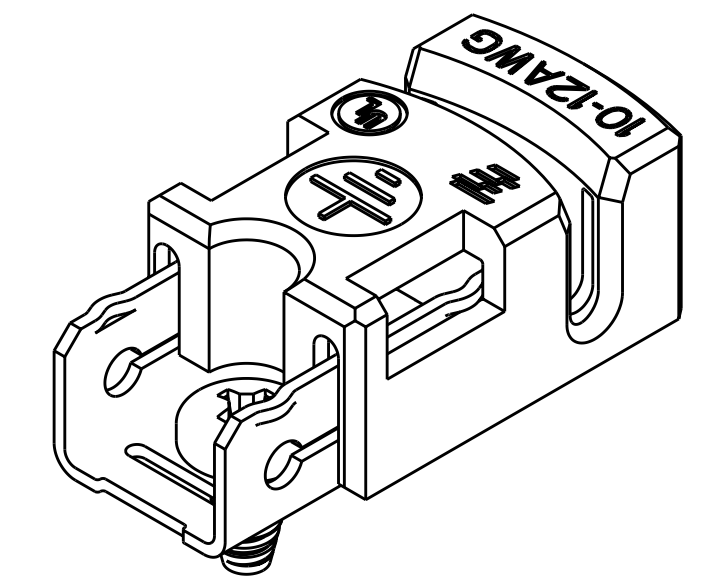
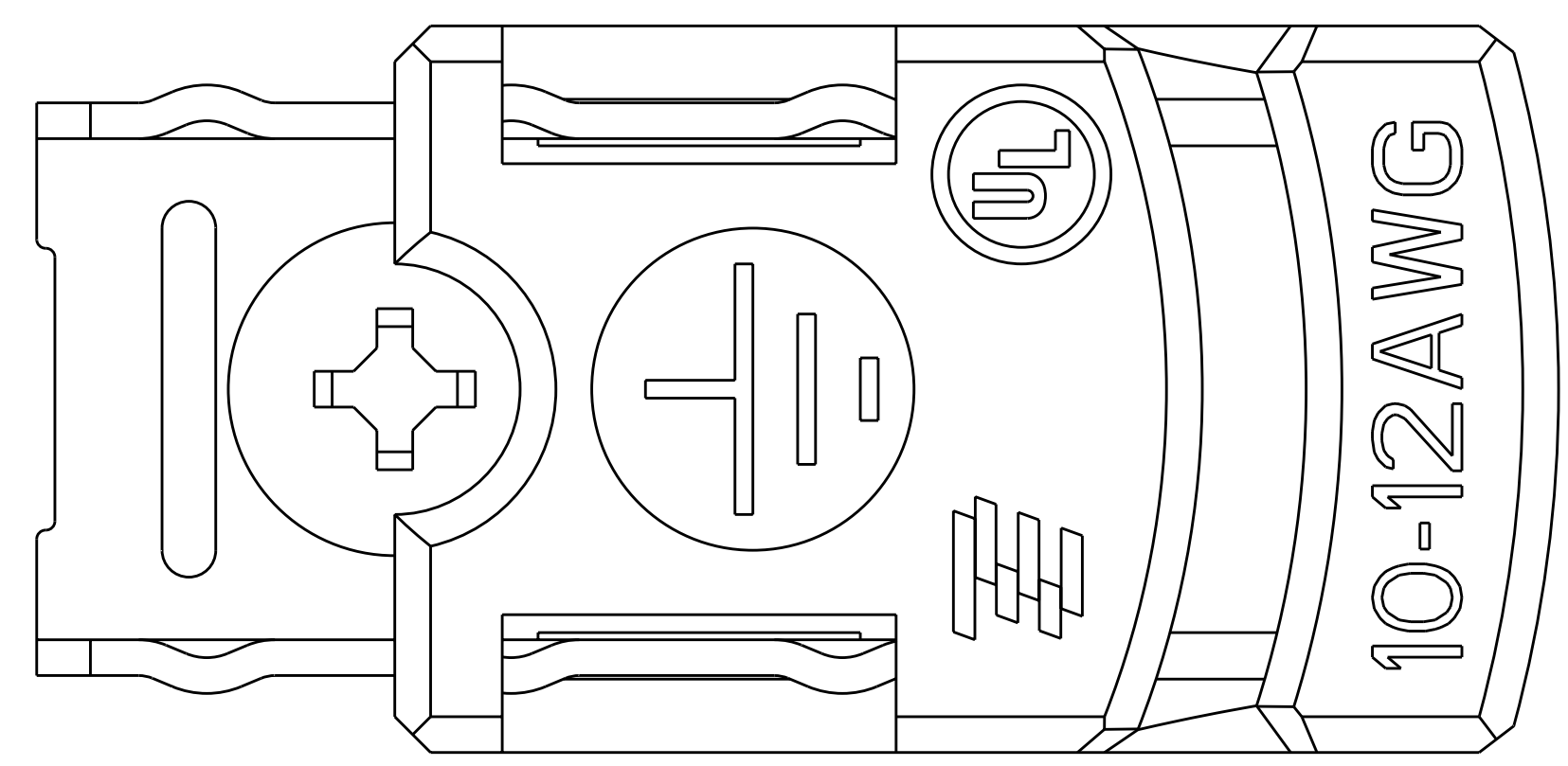
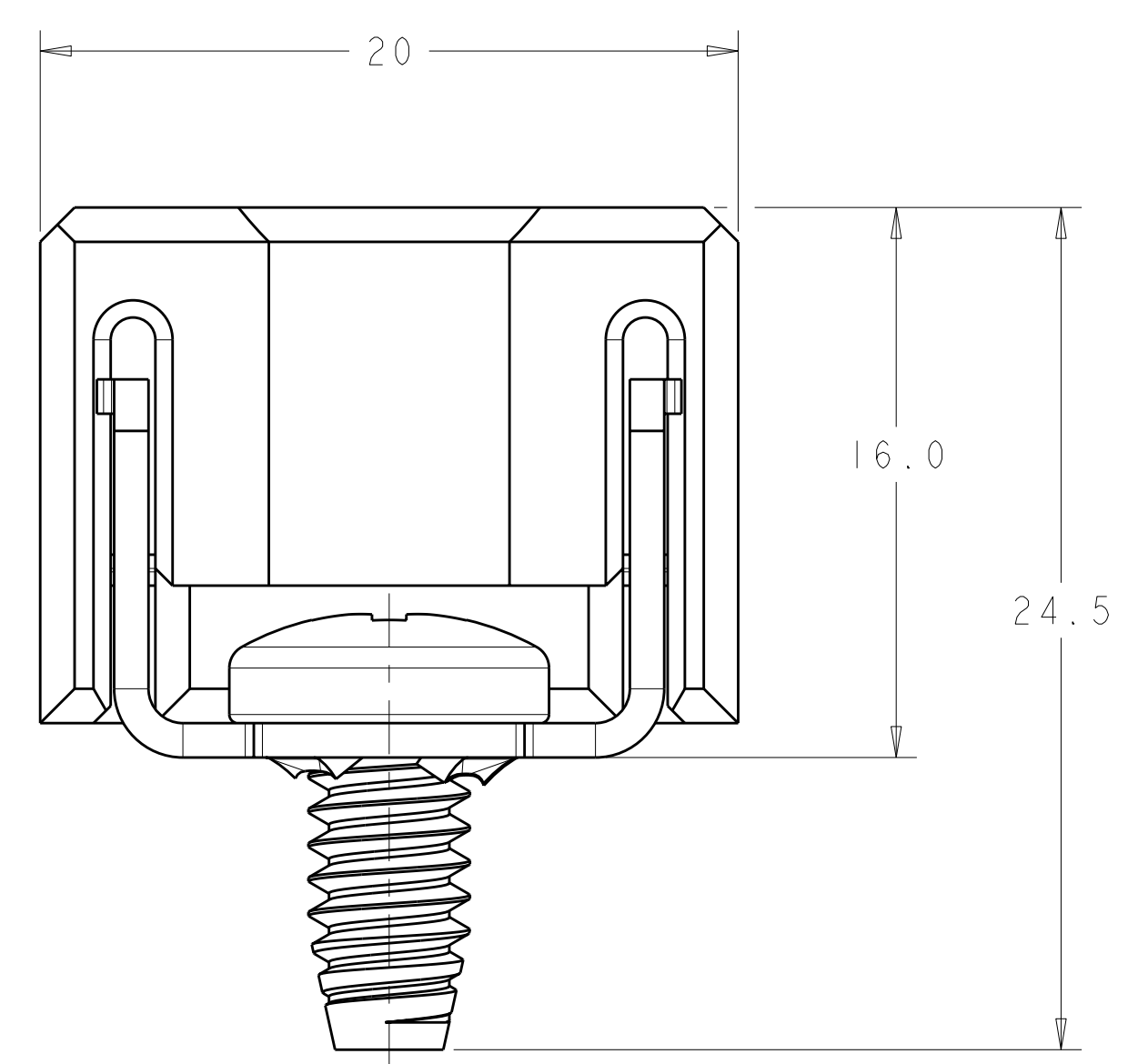

SCALE 2:1

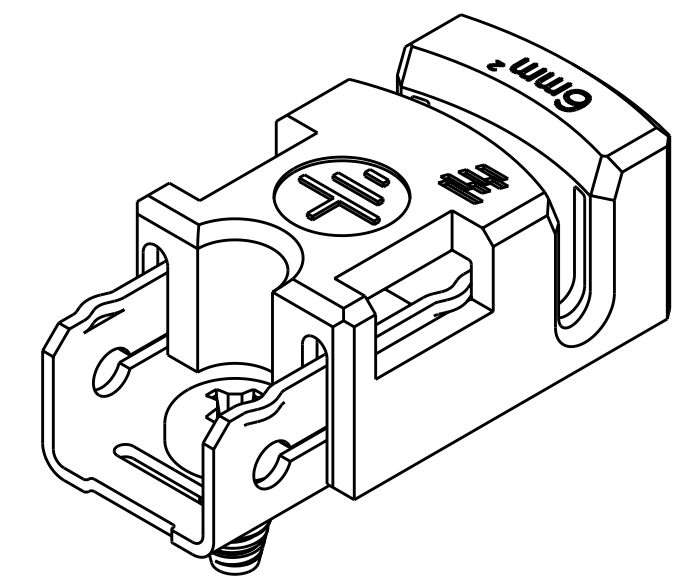

SCALE 2:1  
1954381-5 ONLY

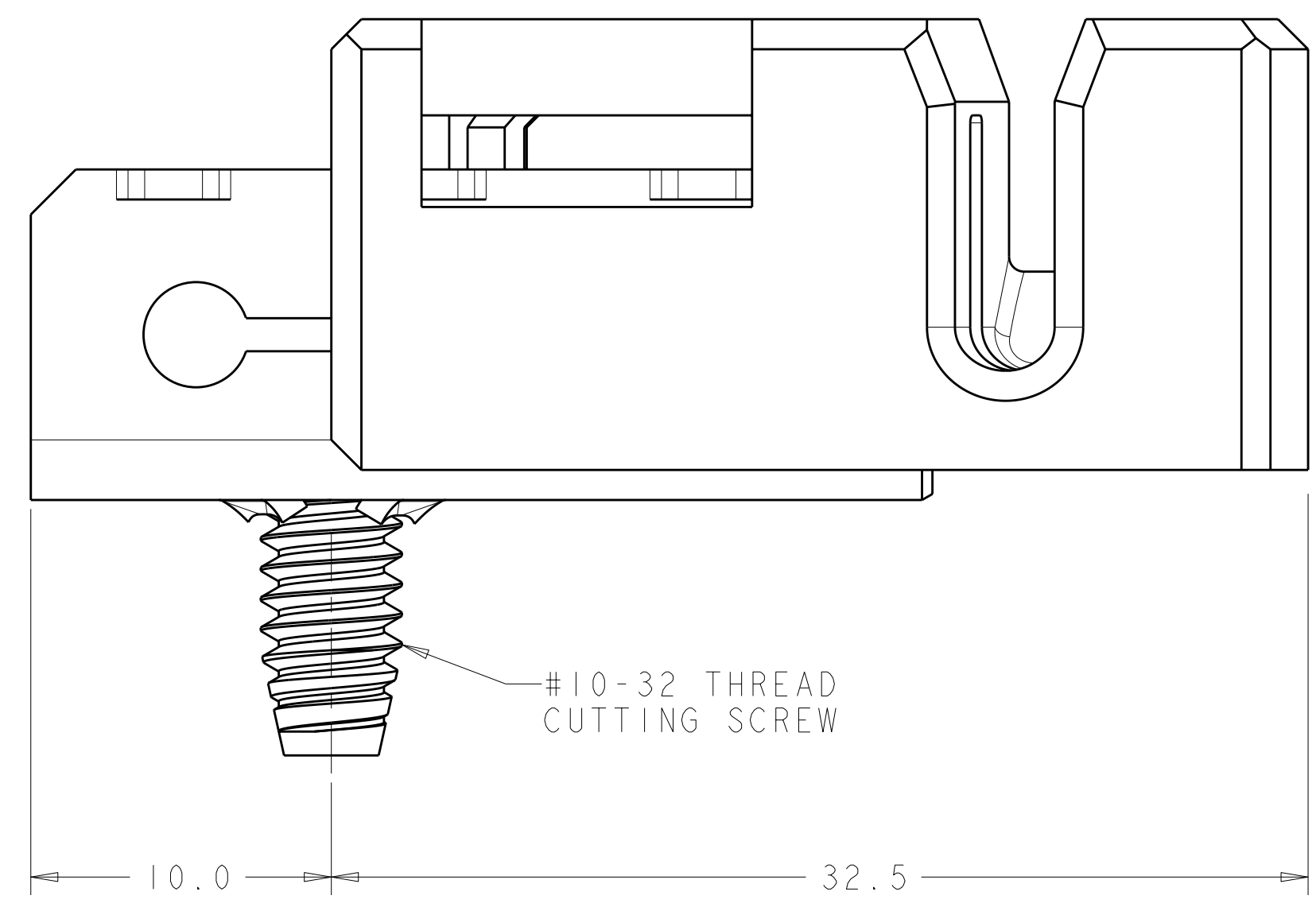

#10-32 THREAD CUTTING SCREW

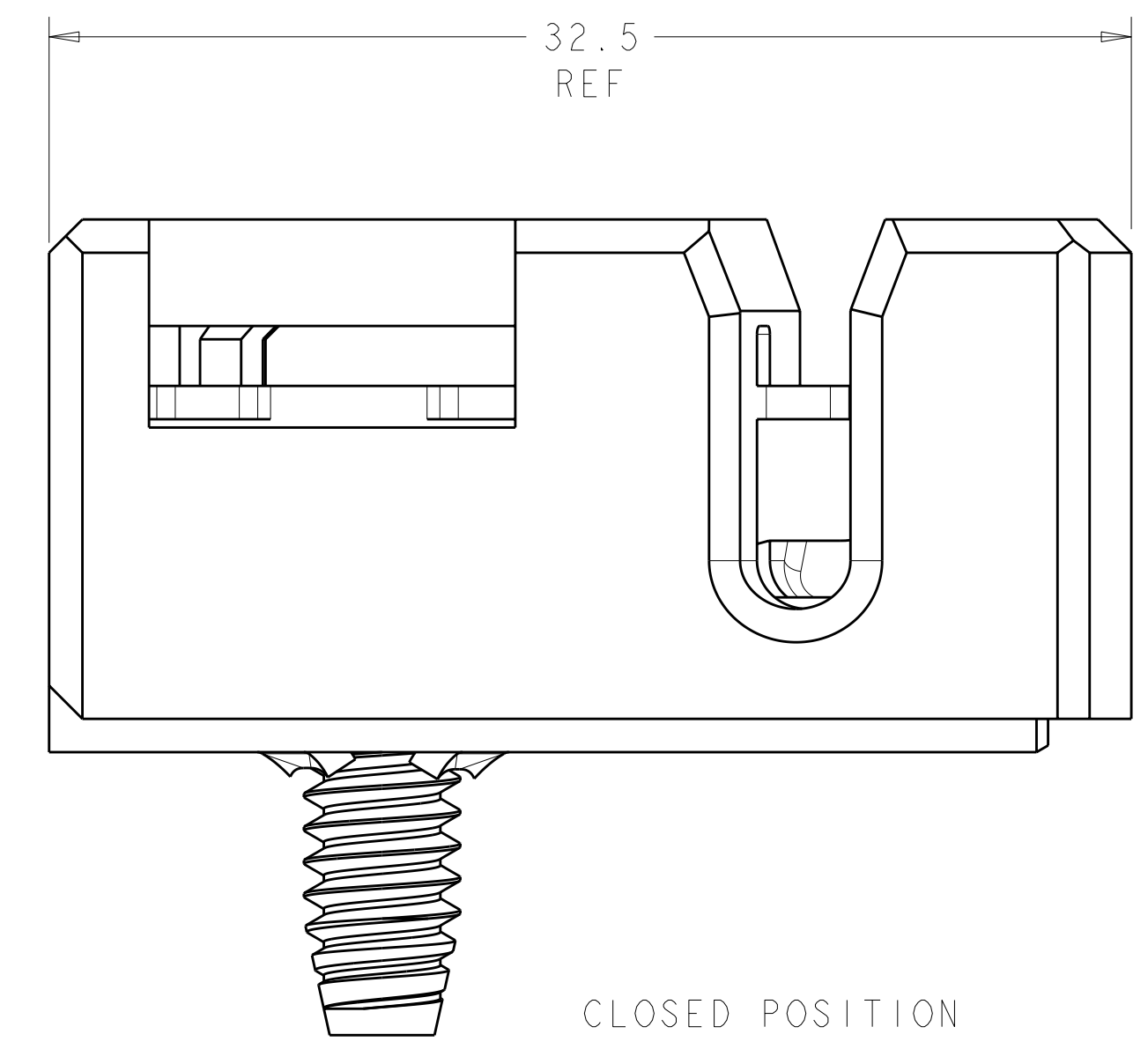

CLOSED POSITION

△ MATERIALS AND FINISH:  
 SLIDER: PBT, UV F1 RATING, BLACK, 94V5  
 BASE: PHOSPHOR BRONZE; FINISH: Sn OVER Ni  
 MOUNTING HARDWARE: STAINLESS STEEL EXCEPT #8-32 HEX NUT WHICH IS CARBON STEEL

2. COMPLIES WITH DIRECTIVE 2002/95/EC (ROHS)
3. PATENTED.

△ NUTS ARE PACKAGED SEPERATELY IN A BAG.

NONE	NONE	6mm <sup>2</sup> AND 4mm <sup>2</sup>	1954381-6
NONE	#10-32 THREAD CUTTING .375LG	6mm <sup>2</sup> AND 4mm <sup>2</sup>	1954381-5
△ NUT WITH LOCKWASHER	#10-32 PAN HEAD .625LG	10-12 AWG, 4mm <sup>2</sup>	1954381-4
△ NUT WITH LOCKWASHER	#8 PAN HEAD .500LG	10-12 AWG, 4mm <sup>2</sup>	1954381-3
△ HEX NUT	#8-32 PAN HEAD .500LG	10-12 AWG, 4mm <sup>2</sup>	1954381-2
NONE	#10-32 THREAD CUTTING .375LG	10-12 AWG, 4mm <sup>2</sup>	1954381-1
NUT	SCREW	WIRE SIZE	PART NUMBER

THIS DRAWING IS A CONTROLLED DOCUMENT.		DRN MOHAN 31OCT2006	TE Connectivity
DIMENSIONS: mm		CHK S. DUESTERHOFF 01NOV2006	
TOLERANCES UNLESS OTHERWISE SPECIFIED:		APVD M. STROCKWALD 01JUN2007	NAME
0 PLC ±.10	1 PLC ±.10	PRODUCT SPEC	GROUNDING CLIP ASSEMBLY SOLID WIRE
2 PLC ±.10	3 PLC ±.10	APPLICATION SPEC	SIZE CAGE CODE DRAWING NO
4 PLC ±.10	ANGLES ±°	WEIGHT	A100779C=1954381
MATERIAL	FINISH	CUSTOMER DRAWING	RESTRICTED TO
		SCALE 5:1	SHEET 1 OF 1 REV D5