

# DATA SHEET

**SUNGMUN CODE :** NSI-10S-TR  
**DESCRIPTION :** SLIDE SWITCH

## **SUNGMUN ELECTRONICS CO., LTD.**

Address 301-302,Bucheon Technopark 345, Seokcheon-ro, Ojeong-gu  
Bucheon-si, Gyeonggi-do, Korea  
TEL. +82-32-328-1941~4  
FAX +82-32-328-1945  
E-mail sungmun@sungmun.co.kr  
Website www.sungmun.com

MRK.	DATE	REVISION	SIGN
△			

**SPECIFICATION**

1. Rating : 0.5A, DC 12V~0.3A, DC24V
2. Contact Resistance : 30mΩ Max
3. Travel : 1.6mm
4. Operating Force : 250gf±150gf
5. Life cycle : 2,000 Cycle(with load)

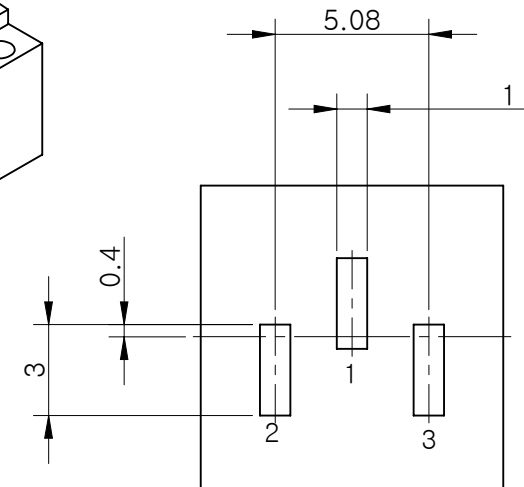
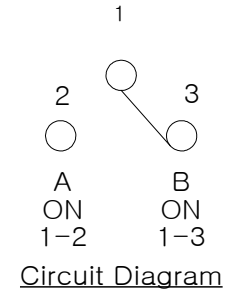
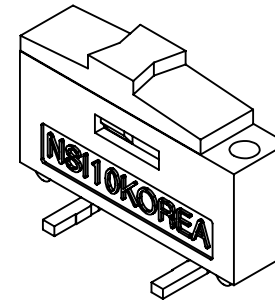
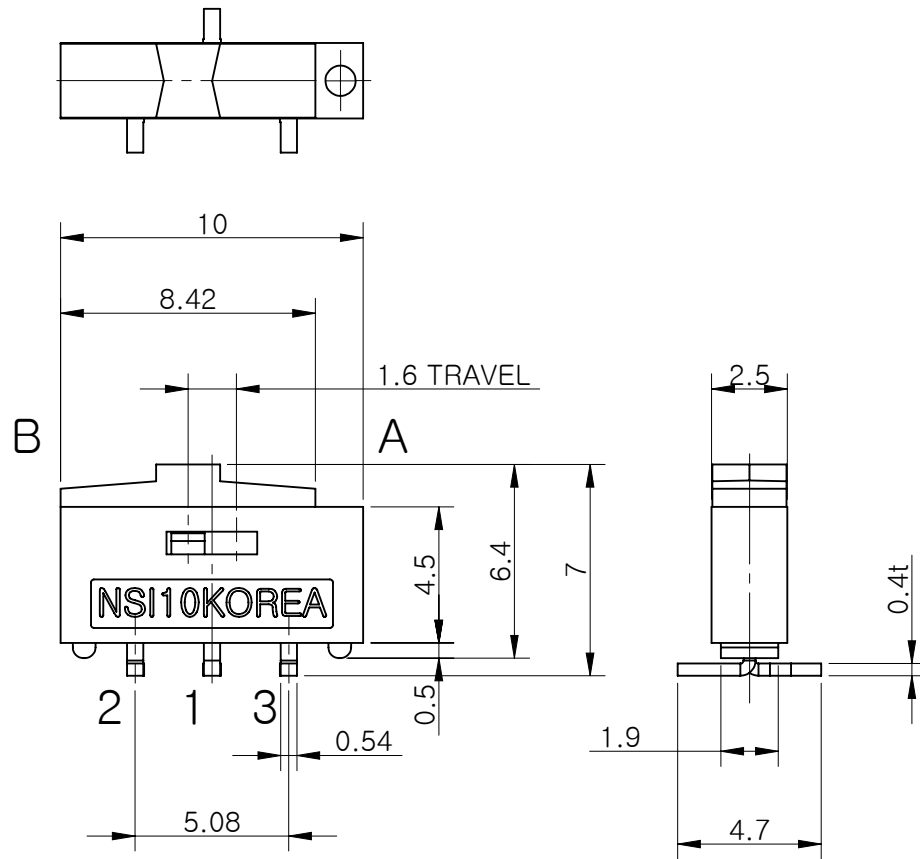

01	SLIDE SWITCH NSI-10	재질 <지정안함>	1	-		
NO.	DESCRIPTION	MATERIAL	COLOR/FINISH	VENDOR		
DRAW/DESIGNED	CHECKED	APPROVED	G.TOL	TITLE		
			±0.1	SLIDE SWITCH NSI-10		
			UNIT	SCALE	MODEL	SHEET
2017-01-24			mm	4:1	NSI-10S	
<b>SUNGMUN ELECTRONICS CO.,LTD</b>			SIZE	DRAW NO.	NSI0-1000S-01	1/1
			A4			

## 1. Electrical Characteristics :

- 1.1 Rating : AC, DC 12V 0.5A~24V 0.3A (Minimum current: 1mA)
- 1.2 Contact Resistance : Max 30 mΩ
- 1.3 Insulation Resistance : Min 10,000 MΩ at DC 500V
- 1.4 Withstanding Voltage : 1min at AC 500V

## 2. Mechanical Characteristics :

- 2.1 Operating Force : 250gf ± 150gf
- 2.2 Travel : 1.6mm
- 2.3 Insulator :
  - 2.3.1 Case : Glass Fiber resin
  - 2.3.2 Slide : Glass Fiber resin
- 2.4 Terminal : Nickel, Gold Plate

## 3. Life Test :

- 3.1 Test Condition : Operations at a rate of 15-20 cycles in 1 minute
  - 3.1.1 With load : 2,000 cycles
  - 3.1.2 Without load : 10,000 cycles
- 3.2 Operating Force : With +40%, -40% of Initial Value
- 3.3 Contact Resistance : Max 200mΩ

## 4. Environmental Characteristics :

- 4.1 Operating Temperature : -40°C to +85°C
- 4.2 Storage Temperature : -40°C to +85°C
- 4.3 Humidity Test :
  - 4.3.1 Test Conditions : Measured 1hour after exposure to ambient  
After 96hours exposure at 40±2°C, 90-95% R.H
  - 4.3.2 Insulation Resistance : Min 100MΩ, at DC 500V
  - 4.3.3 Withstanding Voltage : 1min at AC 250V

## 5. Solder Conditions :

- 5.1 Hand Solder : 3~4 sec. at 350°C (Dipping type)
- 5.2 Wave Solder : 5 sec. at 260°C (Dipping type)
- 5.3 Reflow Solder (SMD type)

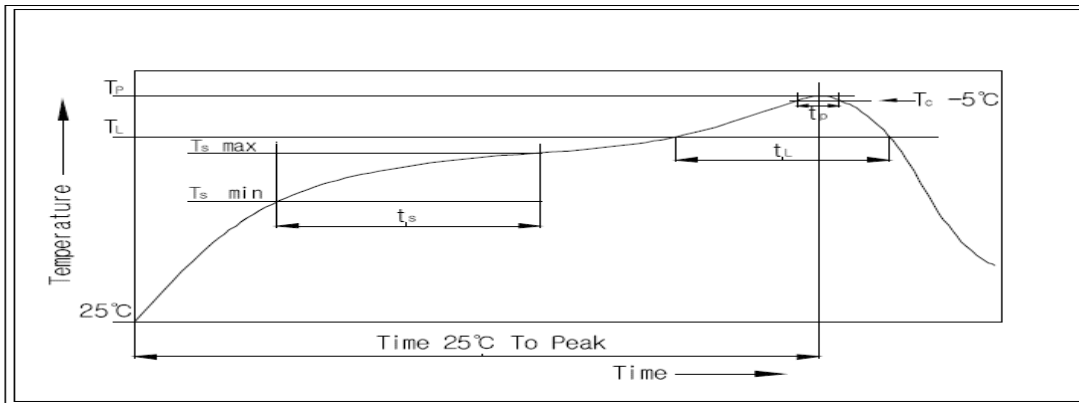

### 5.3.1 Condition for Soldering

Profile Feature	Pb-Free Assembly
Average Ramp-UP Rate(Ts max to TP)	3°C/second max
Preheat	
- Temperature Min(Ts min)	150°C
- Temperature Max(Ts max)	200°C
- Time (ts min to ts max)	60-180seconds
Time maintained above:	
- Temperature (TL)	217°C
- Time (tL)	60-150seconds
Peak/Classification Temperature(TP)	260°C +0°C/ -5°C
Time within 5°C of actual Peak Temperature(TP)	5~10 seconds
Ramp-Down Rate	6°C/sec max
Time 25°C to Peak Temperature	8 minutes max

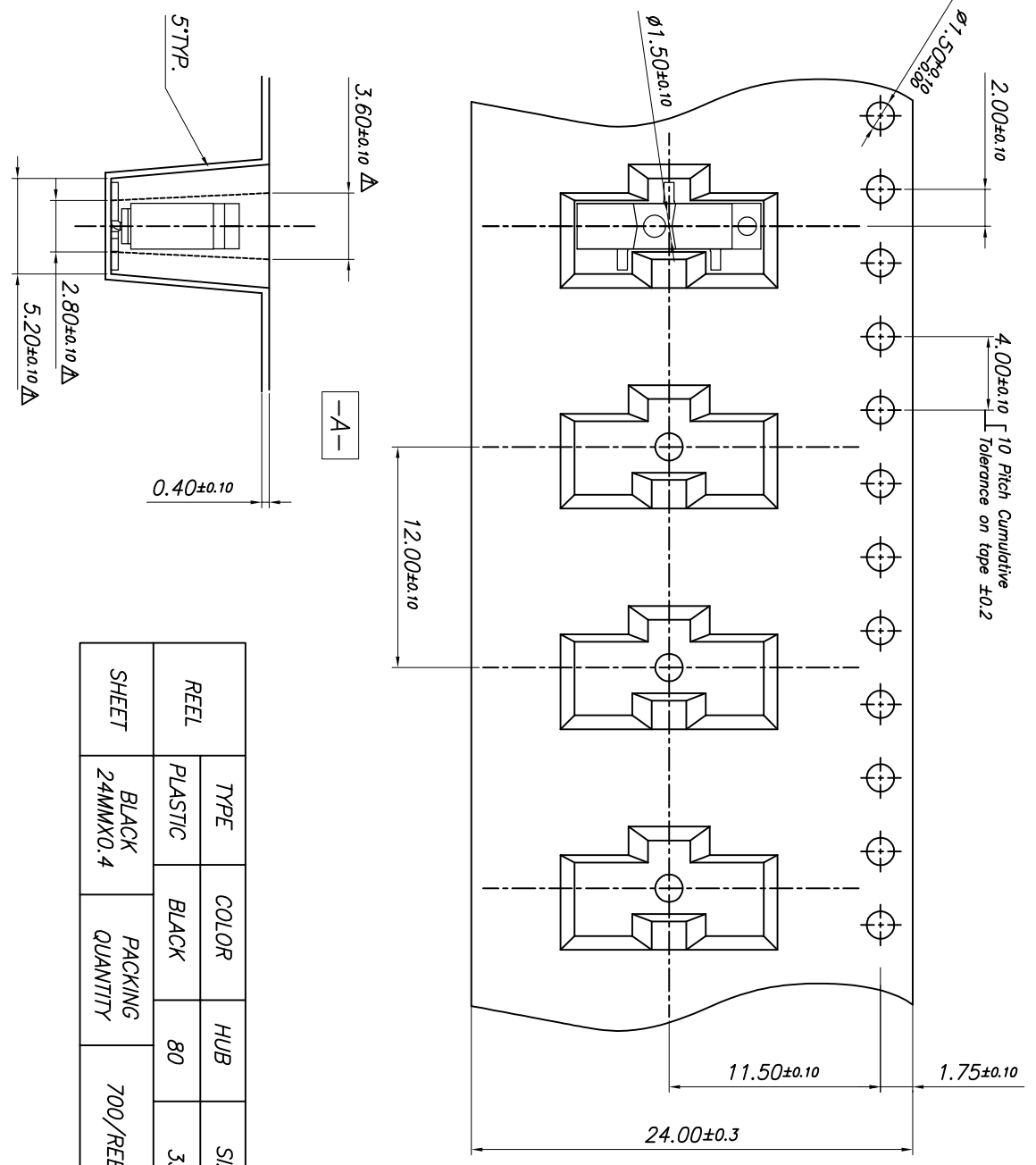
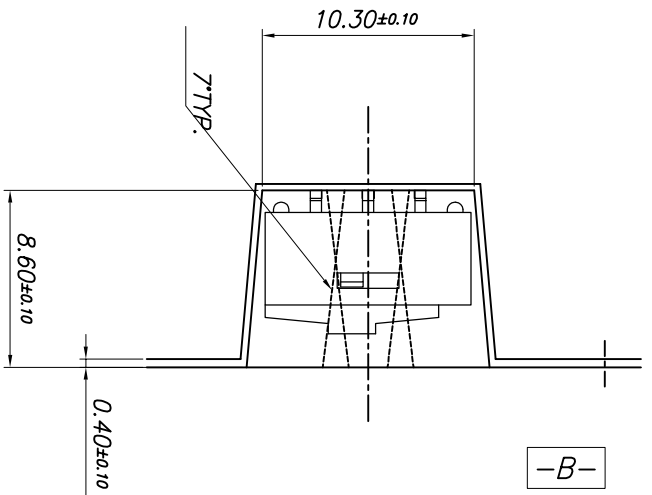

REEL	TYPE	PLASTIC	COLOR	BLACK	HUB	80	SIZE	330
	PACKING QUANTITY	700/REEL						
SHEET	BLACK 24MMX0.4							

- NOTES: (UNLESS OTHERWISE SPECIFIED)
1. TO SPROCKET HOLE PITCH CUMULATIVE TOL ±0.2
  2. CAMBER NOT TO EXCEED 1mm IN 250mm.
  3. MATERIAL : BLACK CONDUCTIVE POLYSTYRENE.
  4. KO MEASURED FROM A PLANE ON THE INSIDE BOTTOM OF THE POCKET TO THE TOP SURFACE OF THE CARRIER.
  5. POCKET POSITION RELATIVE TO SPROCKET HOLE MEASURED AS TRUE POSITION OF POCKET, NOT POCKET HOLE.
  6. ALL DIMENSIONS ARE IN MILLIMETERS.

UNLESS OTHERWISE SPECIFIED:  
DIMENSIONS ARE IN MILLIMETERS

DECIMALS	TOLERANCE	ANGULAR	± °
X.XX ±0.13			
X.XXX ±0.10			

DO NOT SCALE DRAWING

UNIT: mm

THIRD ANGLE PROJECTION

SCALE	NDN SCALE	TITLE
DATE	2019.04.12	NSI-10S
DRAWN	DESIGNED	CHECKED
W.J. LEE		J.P. LEE
		K.I. LEE
SUNGJUN ELECTRONICS, LTD		DWG NO
		NSI-10S