

3.3V Bus LVDS High-Speed Differential Line Drivers and Receivers

Features

- Signaling Rates >660 Mbps (330 MHz)
- Single 3.3V Power Supply Design
- Driver:
 - ±350mV Differential Swing into a 50-ohm load
 - Propagation Delay of 1.5ns Typ.
 - Low Voltage TTL (LVTTTL) Inputs are 5V Tolerant
 - Driver is High Impedance when Disabled or $V_{CC} < 1.5V$
- Receiver:
 - Accepts ±50mV (min.) Differential Swing with up to 2.0V ground potential difference
 - Propagation Delay of 2ns Typ.
 - Low Voltage TTL (LVTTTL) Outputs
 - Open, Short, and Terminated Fail Safe
- Industrial Temperature Operating Range: -40°C to 85°C
- Bus-Terminal ESD ≥12kV
- Packaging (Pb-free & Green available):
 - PI90LVB179: 8-pin SOIC (W) & 8-pin MSOP (U)
 - PI90LVB180: 14-pin TSSOP (L) & 14-pin SOIC (W)
 - PI90LVB050: 16-pin TSSOP (L) & 16-pin SOIC (W)
 - PI90LVB051: 16-pin TSSOP (L) & 16-pin SOIC (W)

Description

The PI90LVB179, PI90LVB180, PI90LVB050, and PI90LVB051 are differential line drivers and receivers (transceivers) that are similar to the IEEE 1596.3 SCI and ANSI/TIA/EIA-644 LVDS standards (the difference is that the driver output current is doubled). This modification enables true half-duplex operation with more than one LVDS driver or with two line transmission resistors over a 50-ohm differential transmission line. These devices use low-voltage differential signaling (LVDS) to achieve data rates in excess of 660 Mbps while being less susceptible to noise than single-ended transmission.

The drivers translate a low-voltage TTL/CMOS input into a low-voltage (350mV typical) differential output signal into a 50-ohm load. The receivers translate a differential 350mV input signal to a 3V CMOS output level. Driver section can be independently set to a power-down & high-impedance output mode with the DEN pin (active HIGH). Receiver section is controlled by the REN* pin (active LOW).

Applications

Applications include point-to-point and multidrop baseband data transmission over a controlled impedance media of approximately 50-ohms. These include intra-system connections via printed circuit board traces or cables, hubs and routers for data communications; PBXs, switches, repeaters & base stations for telecommunications and other applications such as digital cameras, printers and copiers.

PI90LVB179

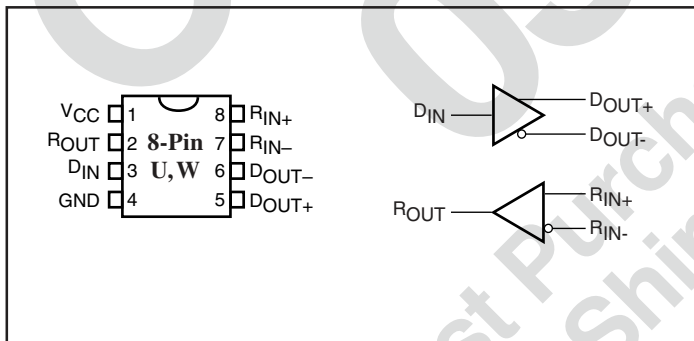

PI90LVB050

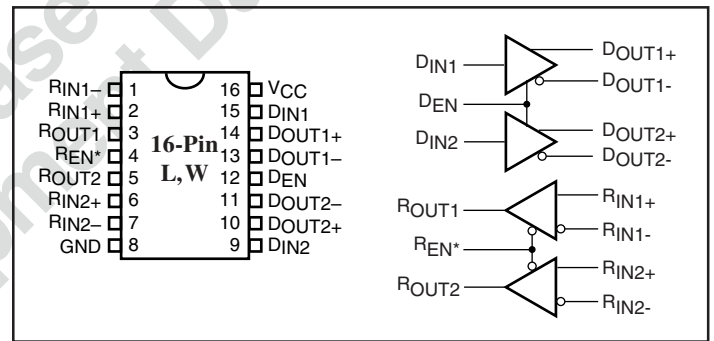

PI90LVB180

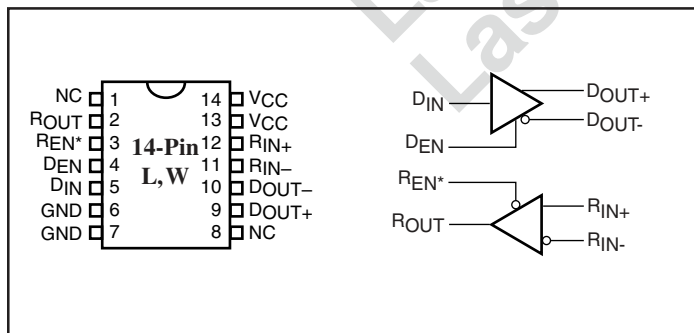

PI90LVB051

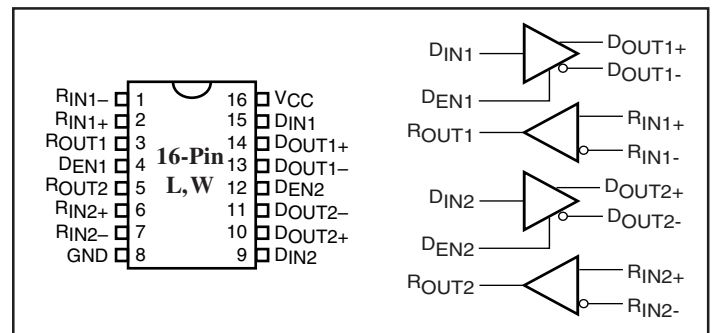

Function Tables

PI90LVB179 Receiver

Inputs	Output
$V_{ID} = V_{RIN+} - V_{RIN-}$	R_{OUT}
$V_{ID} \geq 50mV$	H
$-50mV < V_{ID} < 50mV$?
$V_{ID} \leq -50mV$	L
open	H

PI90LVB179 Driver

Input	Output	
D_{IN}	D_{OUT+}	D_{OUT-}
L	L	H
H	H	L
open	L	H

PI90LVB180/PI90LVB050/PI90LVB051 Receivers

Inputs	Output	
$V_{ID} = V_{RIN+} - V_{RIN-}$	R_{EN*}	R_{OUT}
$V_{ID} \geq 50mV$	L	H
$-50mV < V_{ID} < 50mV$	L	?
$V_{ID} \leq -50mV$	L	L
open	L	H
X	H	Z

PI90LVB180/PI90LVB050/PI90LVB051 Drivers

Inputs		Output	
D_{IN}	D_{EN}	D_{OUT+}	D_{OUT-}
L	H	L	H
H	H	H	L
open	H	L	H
X	L	Z	Z

Notes:

H = High Level, L = Low Level, ? = Indeterminate,
Z = High-Impedance, X = Don't Care

Pin Descriptions

Name	Description
D_{IN}	TTL/CMOS driver input pins
D_{OUT+}	Non-inverting driver output pins
D_{OUT-}	Inverting driver output pins
R_{OUT}	TTL/CMOS receiver output pins
R_{IN+}	Non-inverting receiver input pins
R_{IN-}	Inverting receiver input pins
V_{ID}	Input Differential Signal Voltage
GND	Ground pin
V_{CC}	Positive power supply pin, +3.3V \pm 10%

Absolute Maximum Ratings

Supply Voltage (V_{CC})	-0.5V to +4.0V
Driver	
Input Voltage (D_{IN})	-0.3V to ($V_{CC} + 0.3V$)
Output Voltage (D_{OUT+}, D_{OUT-})	-0.3V to +3.9V
Short Circuit Duration (D_{OUT+}, D_{OUT-})	Continuous
Enable Input Voltage (D_{EN})	-0.3V to ($V_{CC} + 0.3V$)
Receiver	
Input Voltage (R_{IN+}, R_{IN-})	-0.3V to +3.9V
Output Voltage (R_{OUT})	-0.3V to ($V_{CC} + 0.3V$)
Enable Input Voltage (R_{EN*})	-0.3V to ($V_{CC} + 0.3V$)
Storage Temperature Range	-65°C to +150°C
Lead Temperature Range Soldering (4s)	+260°C
Maximum Junction Temperature	+150°C
ESD Rating	>12kV

Recommended Operating Conditions

	Min.	Typ.	Max.	Units
Supply Voltage (V_{CC})	3	3.3	3.6	V
High Level Input Voltage, V_{IH}	2			
Low Level Input Voltage, V_{IL}			0.8	
Magnitude of Differential Input Voltage V_{ID}	0.1		0.6	
Common-mode Input Voltage, V_{IC} (Fig 5)	$ V_{ID} /2$		2.4 - $ V_{ID} /2$ $V_{CC} - 0.8$	
Operating Free Air Temperature T_A	-40		85	°C

Electrical Characteristics (Over recommended operating conditions unless otherwise noted).

Parameter		Test Condition	Min.	Typ. [†]	Max.	Units
I _{CC} * Supply Current	PI90LVB179	No receiver load, Driver R _L = 50-ohms		14	19.5	mA
	PI90LVB180	Driver and receiver enabled. No receiver load, Driver R _L = 50-ohms		12.5	16.4	
		Driver enabled, Receiver disabled, R _L = 50 ohms		10.2	14	
		Driver disabled, Receiver enabled, No load		3.4	5	
		Disabled		0.8	1.5	
		PI90LVB050	Driver and receivers enabled. No receiver loads, Driver R _L = 50-ohms		25	
	Drivers enabled, Receivers disabled, R _L = 50-ohms			14.8	20	
	Drivers disabled, Receivers enabled, No loads			6	8	
	Disabled			0.8	1.3	
	PI90LVB051	Drivers enabled, No receiver loads, Driver R _L = 50-ohms		27	33	
Drivers disabled, No loads			6.5	8.8		

[†]All typical values are at 25°C with a 3.3V supply

*_{CC} measured with all TTL input. V_{IN} = V_{CC} or GND.

Driver Electrical Characteristics (Over recommended operating conditions unless otherwise noted).

Parameter		Test Conditions	Min.	Typ.	Max.	Units
V _{OD}	Differential output voltage magnitude	R _L = 50-ohms See Figures 1 and 2	247	380	475	mV
Δ V _{OD}	Change in differential output voltage magnitude between logic states		-50		50	
V _{OC(SS)}	Steady-state common-mode output voltage	See Figure 3	1.125	1.25	1.375	V
ΔV _{OC(SS)}	Change in steady-state common-mode output voltage between logic states		-50		50	mV
V _{OC(PP)}	Peak-to-peak common-mode output voltage			50	150	
I _{IH}	High-level input current	DE	V _{IH} = 5V	-0.5	-20	μA
		D _{IN}		2	20	
I _{IL}	Low-level input current	DE	V _{IL} = 0.8V	-0.5	-10	
		D _{IN}		2	10	
I _{OS}	Short-circuit output current	V _{OY} or V _{OZ} = 0V		-11	-15	mA
		V _{OD} = 0V		-12	-15	
I _{OZ}	High-impedance output current	V _{OD} = 600mV			±1	μA
		V _O - 0V or V _{CC}			±1	
I _{O(OFF)}	Power-off output current	V _{CC} = 0V, V _O = 3.6V			±1	
C _{IN}	Input capacitance			7		pF

Receiver Electrical Characteristics (Over recommended operating conditions unless otherwise noted).

Parameter		Test Conditions	Min.	Typ.	Max.	Units	
V _{I TH+}	Positive-going differential input voltage threshold	See Figures 5 & Table 1			50	mV	
V _{I TH-}	Negative-going differential input voltage threshold		-50				
V _{OH}	High-level output voltage	I _{OH} = -8mA	2.4			V	
V _{OL}	Low-level output voltage	I _{OL} = 8mA			0.4	V	
I _I	Input current (R _{IN+} or R _{IN-})	V _I = 0	-2	-11	-20	μA	
		V _I = 2.4V	-1.2	-3			
I _{I (OFF)}	Power-off input current (R _{IN+} or R _{IN-})	V _{CC} = 0			±20		
I _H	High-level input current (enables)	V _{IH} = 2V			±10		
I _L	Low-level input current (enables)	V _{IL} = 0.8V			±10		
I _{OZ}	High-impedance output current	V _O = 0 or 5V			±10		
C _I	Input capacitance			6.6			pF

† All typical values are at 25°C with a 3.3V supply

Driver Switching Characteristics (Over recommended operating conditions unless otherwise noted).

Parameter		Test Conditions	Min.	Typ.†	Max.	Units	
t _{PLH}	Propagation delay time, low-to-high-level output	R _L = 50-ohms C _L = 10pF See Figure 2		1.7	2.6	ns	
t _{PHL}	Propagation delay time, high-to-low-level output			1.7	2.6		
t _r	Differential output signal rise time			0.4	0.8		
t _f	Differential output signal fall time			0.4	0.8		
t _{sk(p)}	Pulse skew (t _{PHL} - t _{PLH})				250	360	ps
t _{sk(o)}	Channel-to-channel output skew‡				90	160	
t _{sk(pp)}	Part-part-part skew**					0.9	ns
t _{PZH}	ENABLE TIME, High Impedance to High Level output		See Figure 4		3	5	
t _{PZL}	ENABLE TIME, High Impedance to Low Level output			3	5		
t _{PHZ}	DISABLE TIME, High Level to High Impedance output			3	5		
t _{PLZ}	DISABLE TIME, Low Level to High Impedance output			3	5		

† All typical values are at 25°C with a 3.3V supply

‡ t_{sk(o)}: the maximum delay time difference between drivers on the same device.

** t_{sk(pp)}: magnitude of difference in propagation delay times between any specific terminals of two devices (all things being equal)

Receiving Switching Characteristics (Over recommended operating conditions unless otherwise noted).

Parameter		Test Conditions	Min.	Typ. [†]	Max.	Units	
t_{PLH}	Propagation delay time, low-to-high-level output	$C_L = 10pF$ See Figure 6		2	3.0	ns	
t_{PHL}	Propagation delay time, high-to-low-level output			2.1	3.0		
$t_{sk(pp)**}$	Part-part-part skew**				1.0		
$t_{sk(p)}$	Pulse skew ($t_{PHL} - t_{PLH}$)				300	750	ps
$t_{sk(o)}$	Channel-to-channel skew				60		
t_r	Output signal rise time				1.0	1.5	ns
t_f	Output signal fall time			1.2	1.8		
t_{PZH}	ENABLE TIME, High Impedance to High Level output	See Figure 7		1.7	2.3		
t_{PZL}	ENABLE TIME, High Impedance to Low Level output			4.5	5.7		
t_{PHZ}	DISABLE TIME, High Level to High Impedance output			2.5	3.2		
t_{PLZ}	DISABLE TIME, Low Level to High Impedance output			6.0	7.8		

[†] All typical values are at 25°C with a 3.3V supply.

** $t_{sk(pp)}$ is magnitude of difference in propagation delay times between any specific terminals of two devices (all things being equal).

Parameter Measurement Information

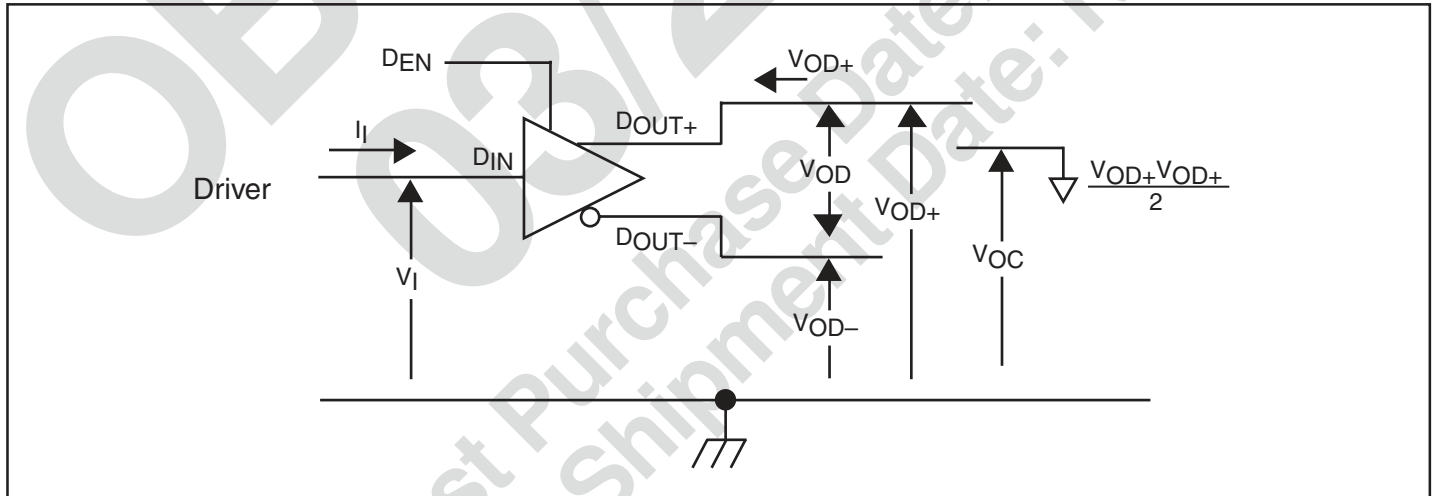

Figure 1. Driver Voltage and Current Definitions

Parameter Measurement Information

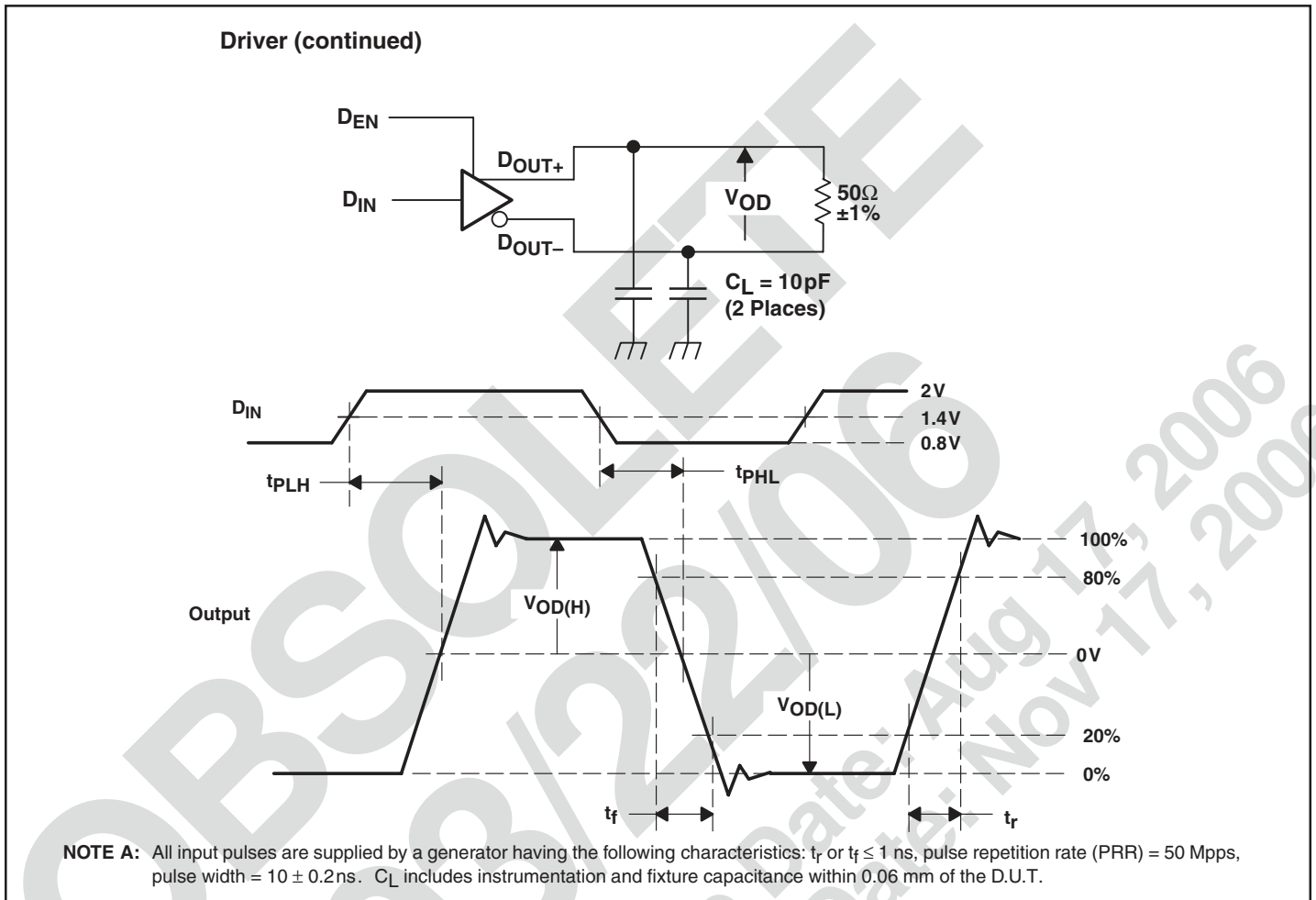

Figure 2. Test Circuit, Timing, and Voltage Definitions for the Differential Output Signal

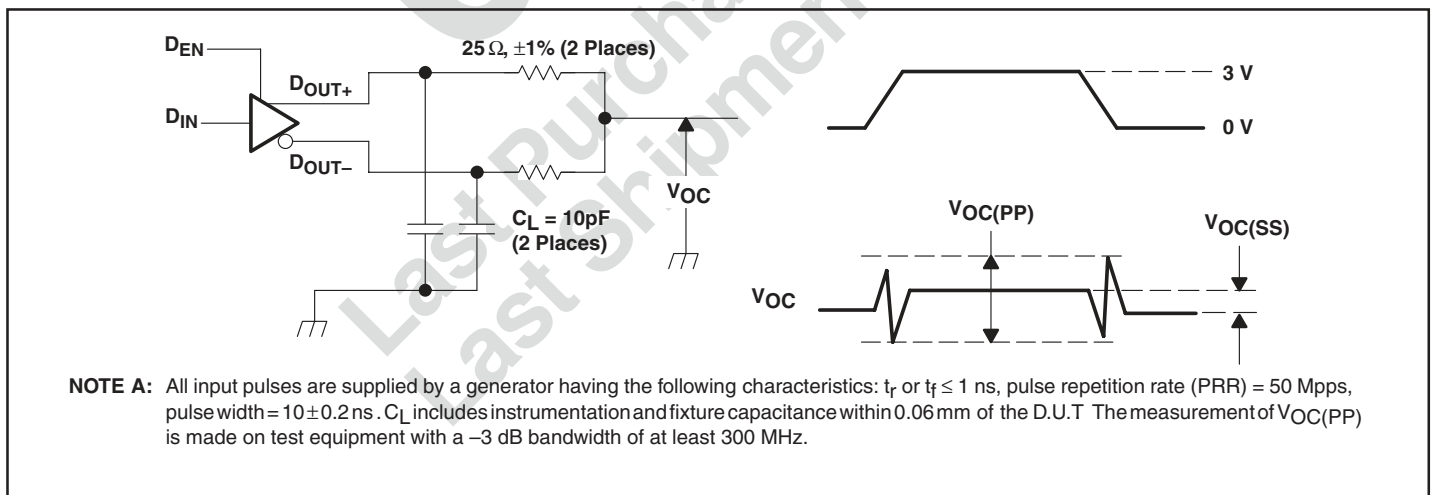

Figure 3. Test Circuit and Definitions for the Driver Common-Mode Output Voltage

Parameter Measurement Information (continued)

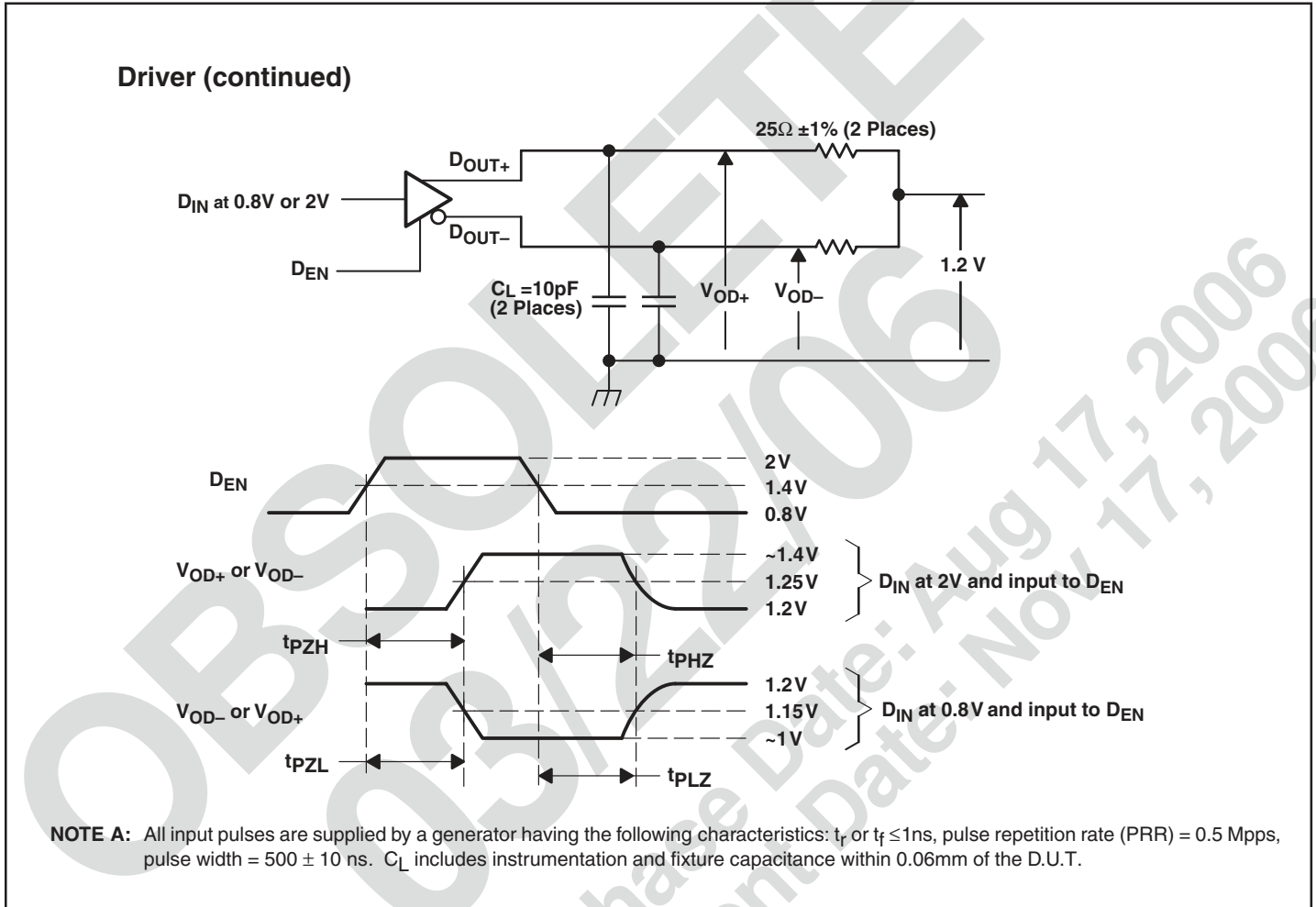

Figure 4. Enable and Disable Timing Circuit and Definitions

Parameter Measurement Information (continued)

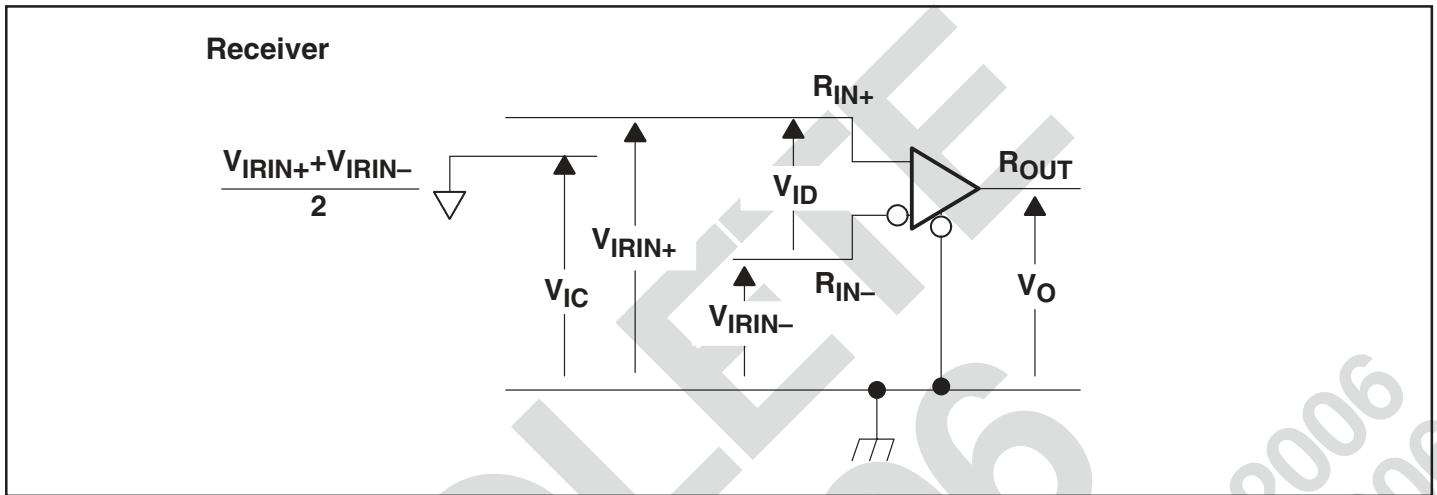

Figure 5. Receiver Voltage Definitions

Table 1. Receiver Minimum and Maximum Input Threshold Test Voltages

APPLIED VOLTAGES (V)		RESULTING DIFFERENTIAL INPUT VOLTAGE (mV)	RESULTING COMMON-MODE INPUT VOLTAGE (V)
V_{IRIN+}	V_{IRIN-}	V_{ID}	V_{IC}
1.225	1.175	50	1.2
1.175	1.225	-50	1.2
2.375	2.325	50	2.35
2.325	2.375	-50	2.35
0.1	0	50	0.05
0	0.05	-50	0.05
1.5	0.9	600	1.2
0.9	1.5	-600	1.2
2.4	1.8	600	2.1
1.8	2.4	-600	2.1
0.6	0	600	0.3
0	0.6	-600	0.3

Parameter Measurement Information (continued)

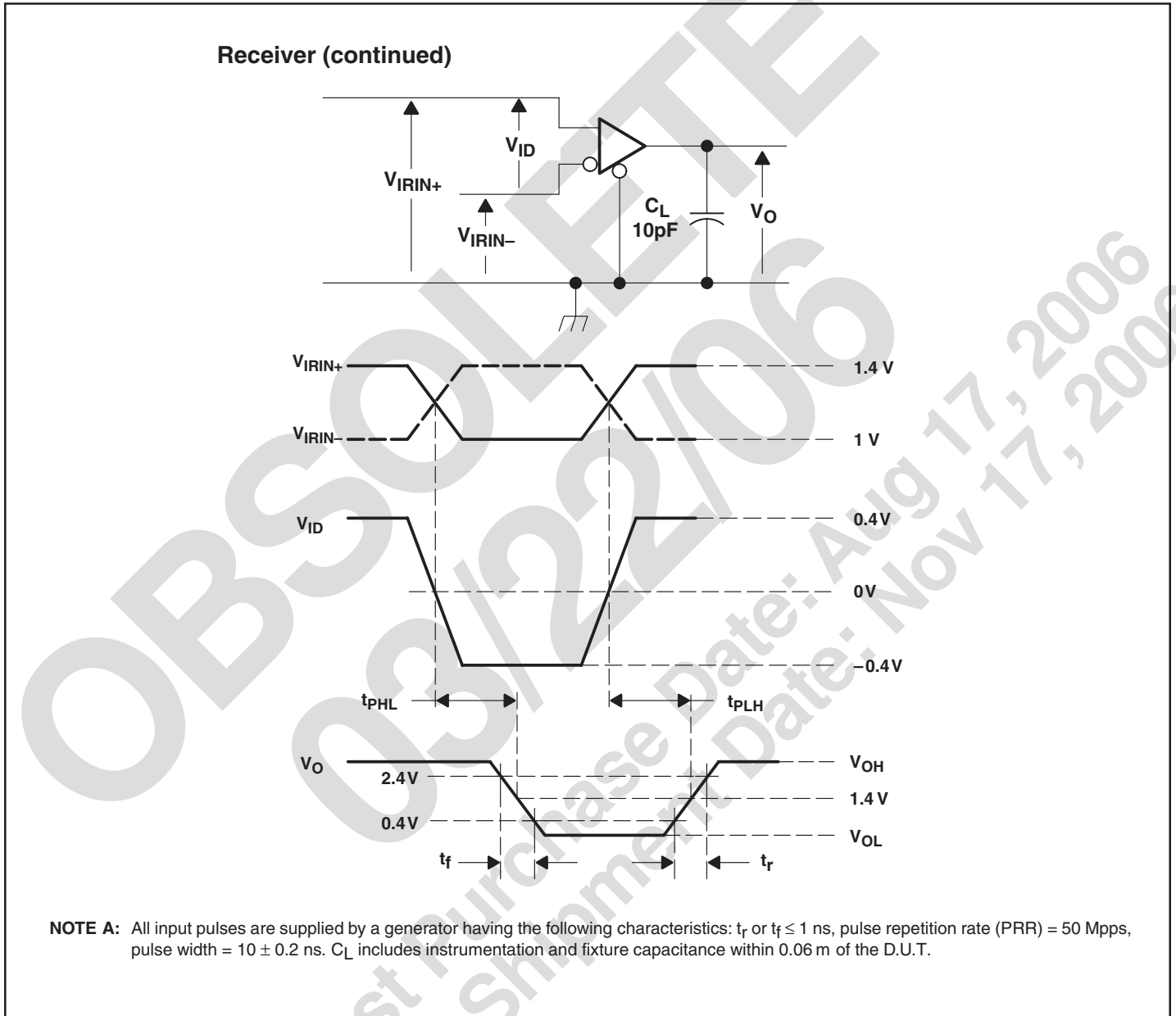
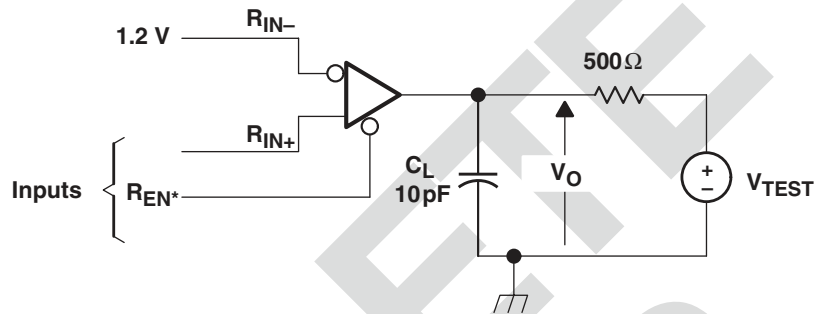

Figure 6. Timing Test Circuit and Waveforms

Parameter Measurement Information (continued)

Receiver (continued)



NOTE A: All input pulses are supplied by a generator having the following characteristics: t_r or $t_f \leq 1$ ns, pulse repetition rate (PRR) = 0.5 Mpps, pulse wide = 500 ± 10 ns. C_L includes instrumentation and fixture capacitance within 0.06m of the D.U.T.

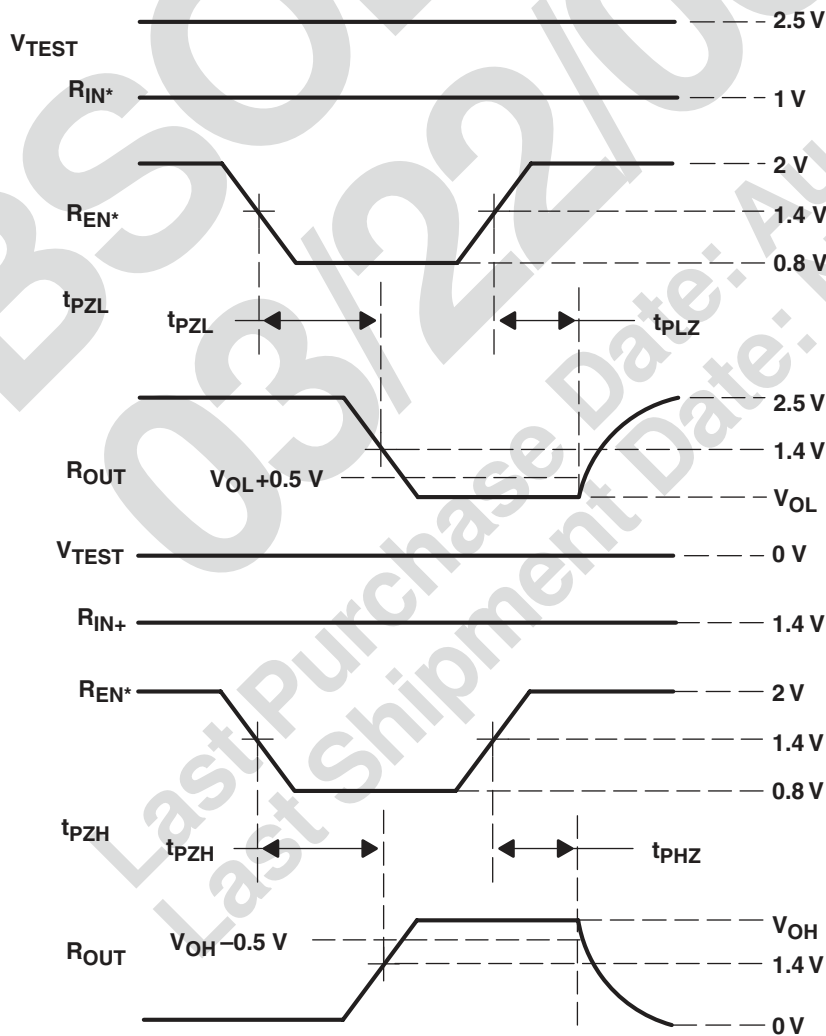
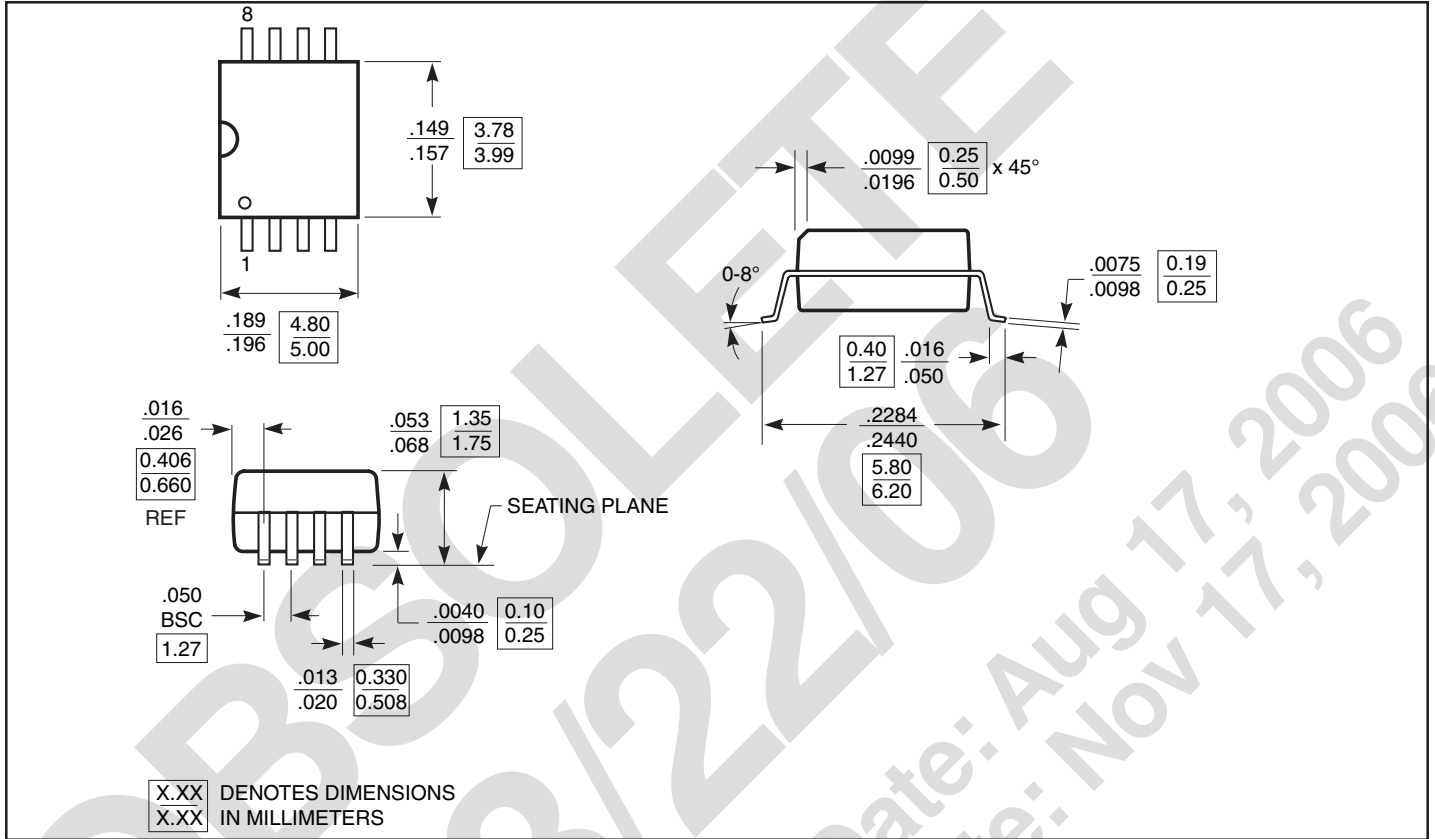
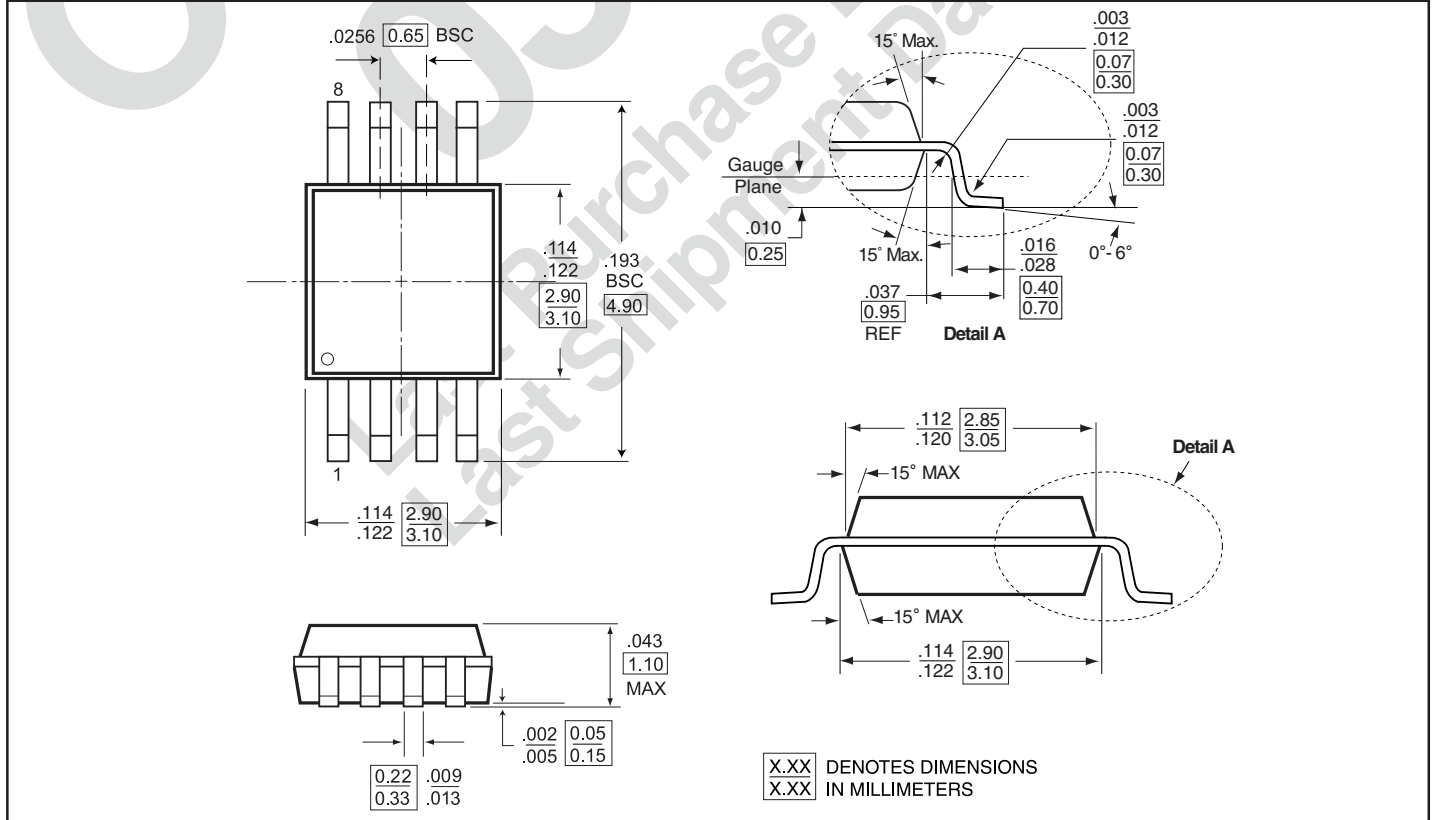

Figure 7. Enable/Disable Time Test Circuit and Waveforms

Packaging Mechanical: 8-Pin SOIC (W)



Packaging Mechanical: 8-Pin MSOP (U)



Packaging Mechanical: 14-Pin SOIC(W)

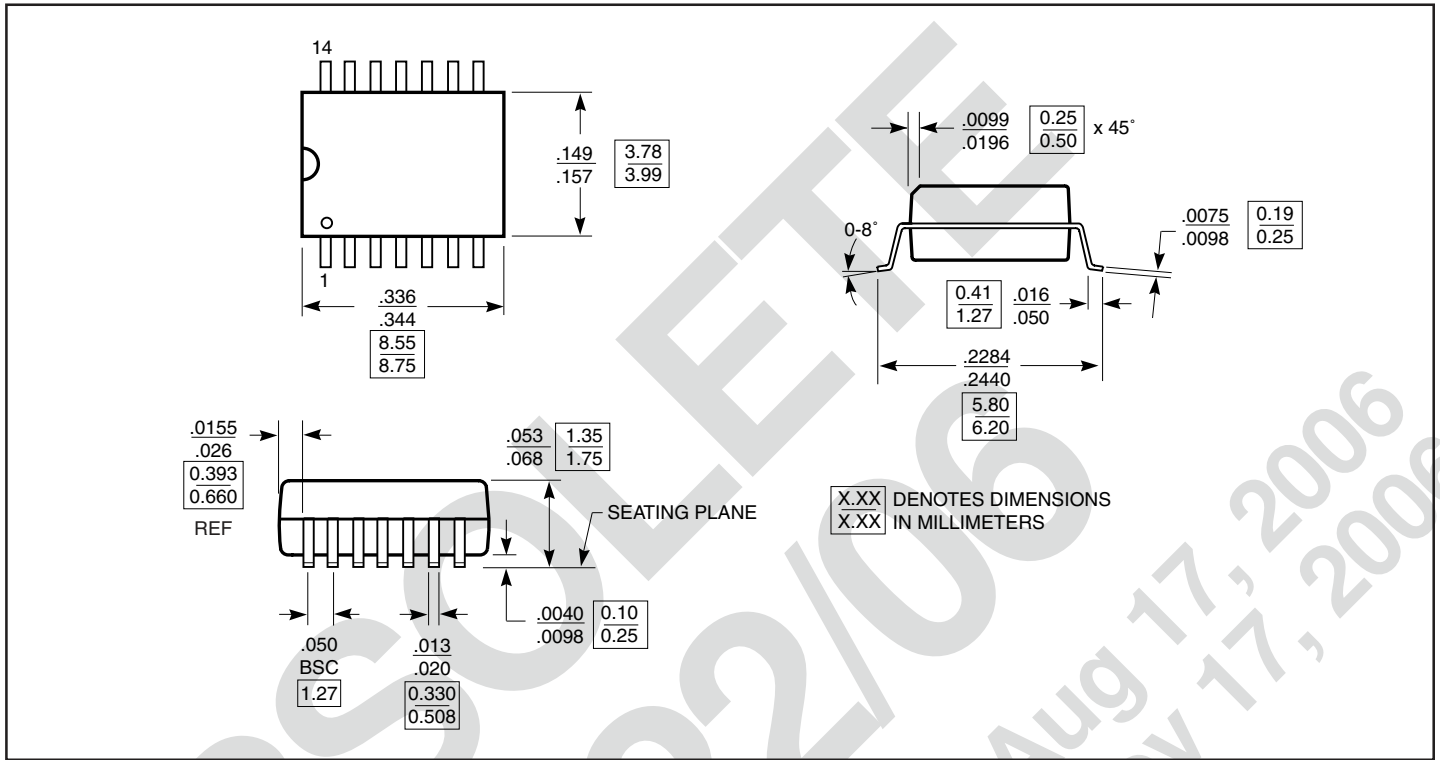

Packaging Mechanical: 14-Pin TSSOP(L)

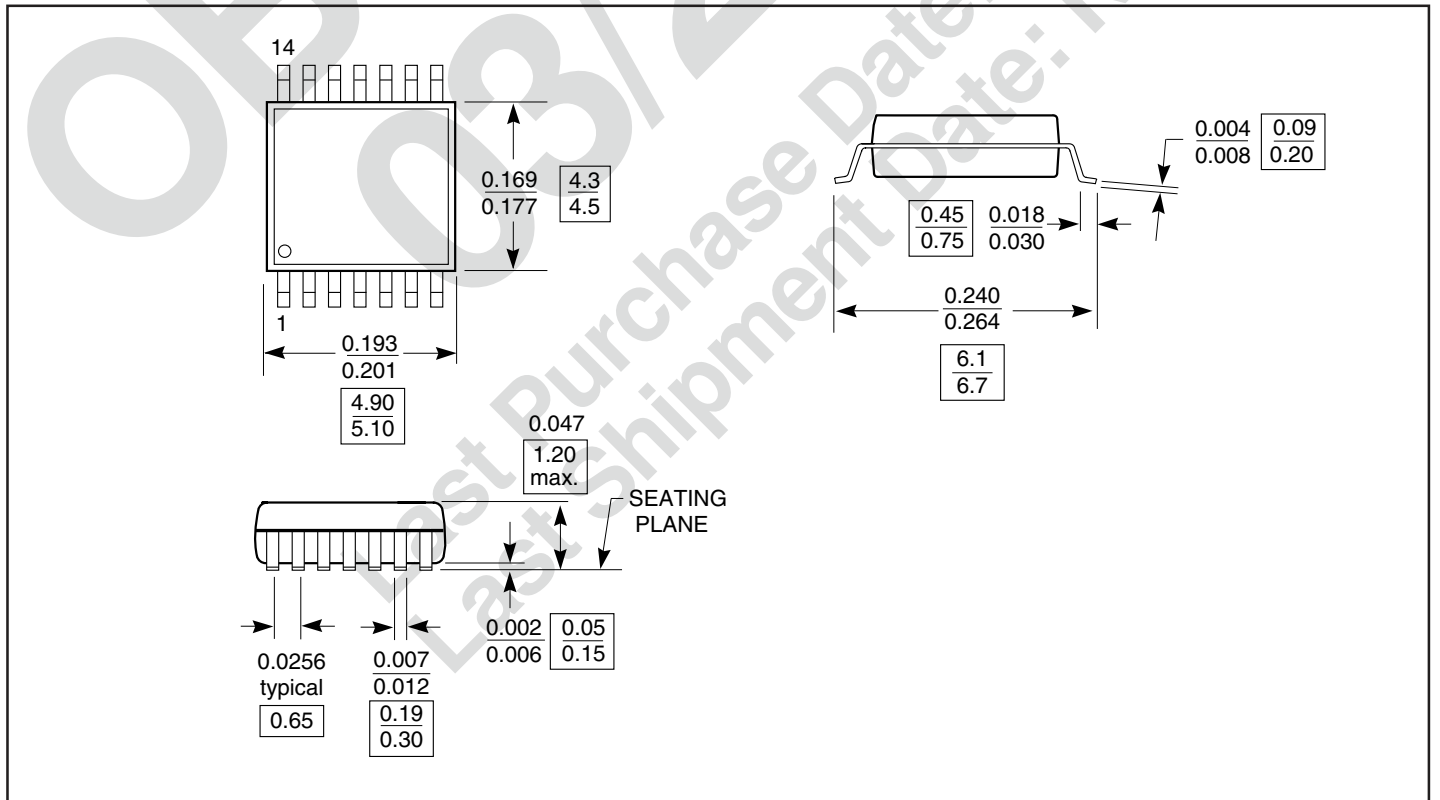

Packaging Mechanical: 16-Pin SOIC (W)

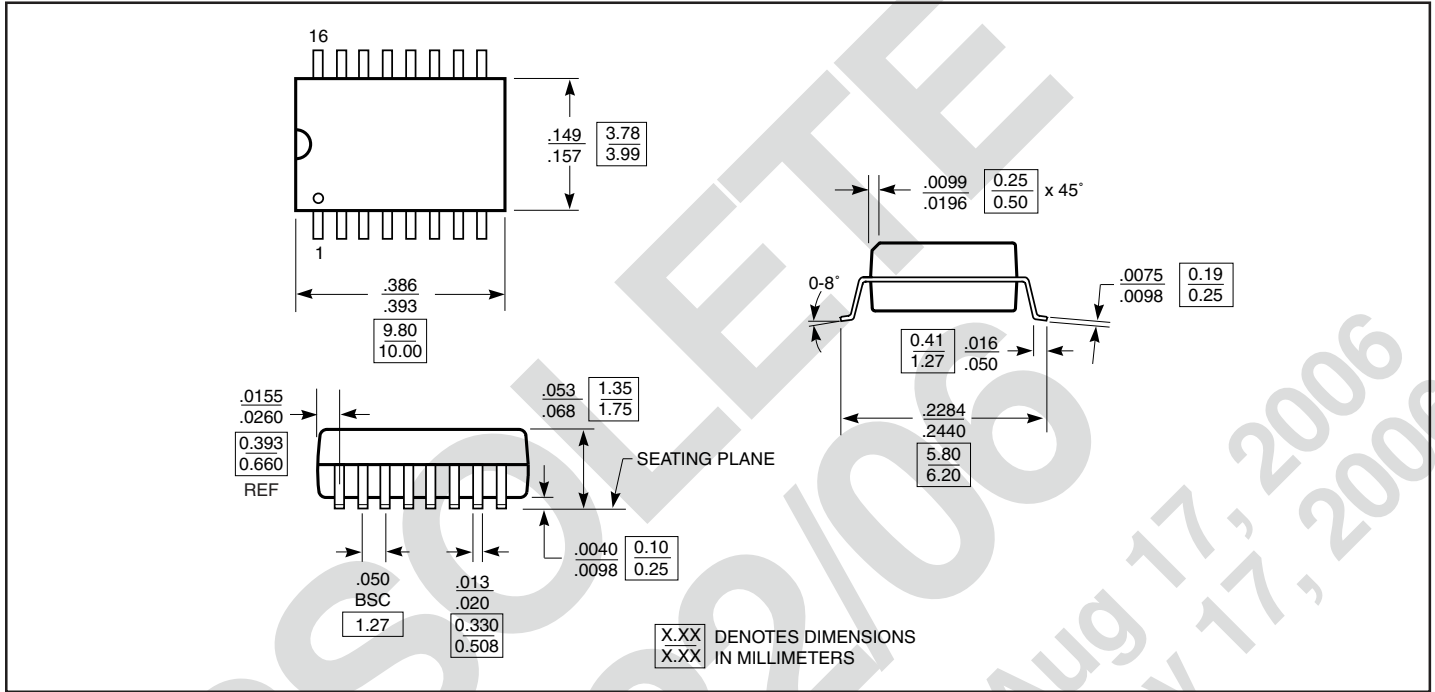

Packaging Mechanical: 16-Pin TSSOP (L)

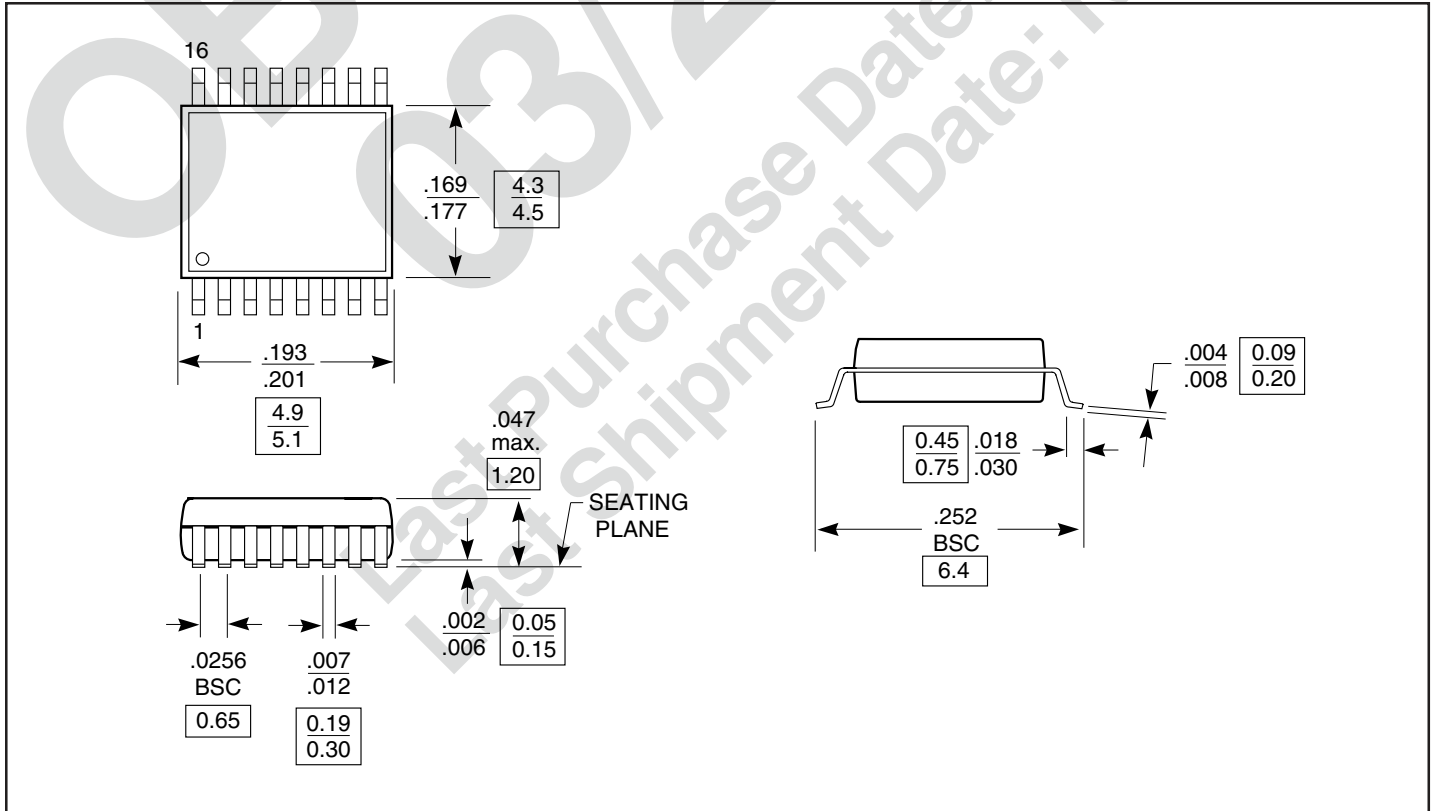



Ordering Information

Ordering Code	Package Code	Package Type
PI90LVB179U	U	8-pin MSOP
PI90LVB179UE	U	Pb-free & Green, 8-pin MSOP
PI90LVB179W	W	8-pin SOIC
PI90LVB179WE	W	Pb-free & Green, 8-pin SOIC
PI90LVB180L	L	14-pin TSSOP
PI90LVB180LE	L	Pb-free & Green, 14-pin TSSOP
PI90LVB180W	W	14-pin SOIC
PI90LVB180WE	W	Pb-free & Green, 14-pin SOIC
PI90LVB050L	L	16-pin TSSOP
PI90LVB050LE	L	Pb-free & Green, 16-pin TSSOP
PI90LVB050W	W	16-pin SOIC
PI90LVB050WE	W	Pb-free & Green, 16-pin SOIC
PI90LVB051L	L	16-pin TSSOP
PI90LVB051LE	L	Pb-free & Green, 16-pin TSSOP
PI90LVB051W	W	16-pin SOIC
PI90LVB051WE	W	Pb-free & Green, 16-pin SOIC

Notes:

1. Thermal characteristics can be found on the company web site at www.pericom.com/packaging/