

PRODUCT NO.  
10150526-XXXIHLF

- NOTES:
- MATERIAL:
    - HOUSING: HIGH TEMPERATURE MATERIAL UL94V-0, BLACK
    - TERMINAL: COPPER ALLOY
    - HOLD DOWN: BRASS
  - FINISH:
    - TERMINAL: 1.27um MIN. NICKEL UNDER PLATING; TIN OR GOLD ON CONTACT AREA (SEE PLATING SPEC. REQUIREMENTS);
    - HOLD DOWN: 1.27um MIN. NICKEL UNDER PLATING; 2.5um MIN. TIN OVER ALL;
  - LEAD FREE PRODUCT MEETS EUROPEAN UNION DIRECTIVES AND OTHER COUNTRY REGULATIONS AS DESCRIPTION IN GS-22-008
  - PRODUCT SPEC: GS-12-1536
  - PACKAGE SPEC: GS-14-2702
  - THE HOUSING WILL WITHSTAND EXPOSURE TO 260°C PEAK TEMPERATURE FOR 40 SECONDS IN A CONVECTION, INFRA-RED OR VAPOR PHASE REFLOW OVEN.
  - OPERATING TEMPERATURE: -25°C to 85°C
  - DIMENSIONS TOLERANCE : TO BE DEFINED IN THE TITLE BAR.
  - PART NUMBER: 10150526-XX X I HLF

CIRCUITS NUMBER (05 MEANS 5 POS.)      RESERVE NUMBER

PLATING SPEC.:  
1-2um MIN. TIN OVER ALL.  
2-0.76um MIN. AU OR 30GXT ON CONTACT AREA.

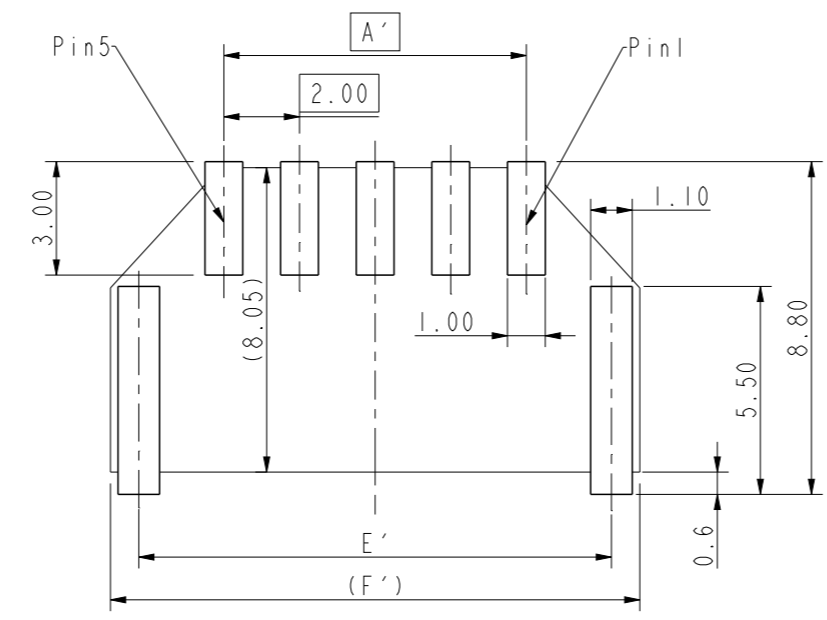

RECOMMENDED PCB LAYOUT: COMPONENTS SIDE  
TOLERANCE: ±0.05

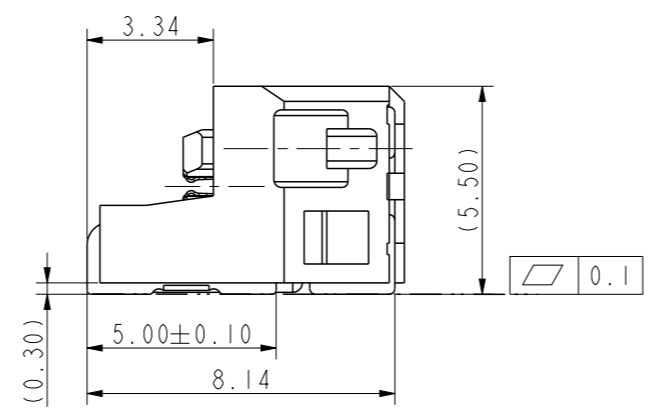

CIRCUITS	DIMENSIONS						
	A&A'	B	C	D	E&E'	F&F'	G
02	2.00	4.10	4.70	5.30	6.50	8.00	2.90
03	4.00	6.10	6.70	7.30	8.50	10.00	4.90
04	6.00	8.10	8.70	9.30	10.50	12.00	6.90
05	8.00	10.10	10.70	11.30	12.50	14.00	8.90
06	10.00	12.10	12.70	13.30	14.50	16.00	10.90
07	12.00	14.10	14.70	15.30	16.50	18.00	12.90
08	14.00	16.10	16.70	17.30	18.50	20.00	14.90
09	16.00	18.10	18.70	19.30	20.50	22.00	16.90
10	18.00	20.10	20.70	21.30	22.50	24.00	18.90
11	20.00	22.10	22.70	23.30	24.50	26.00	20.90
12	22.00	24.10	24.70	25.30	26.50	28.00	22.90

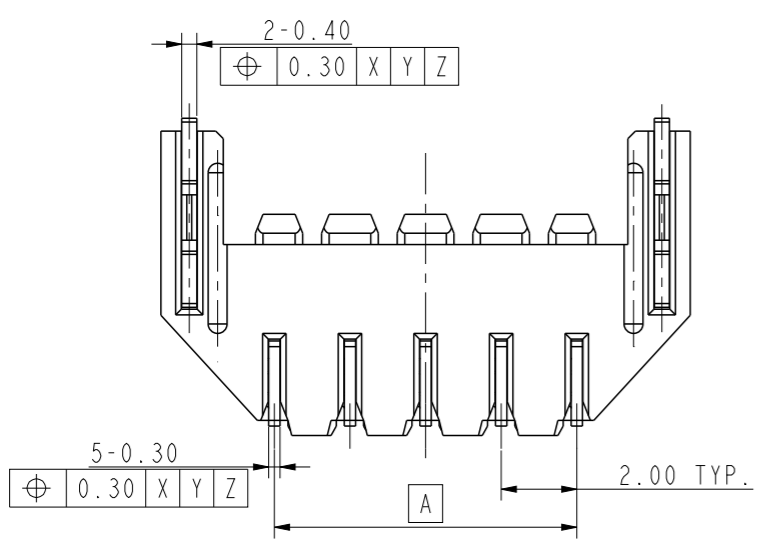
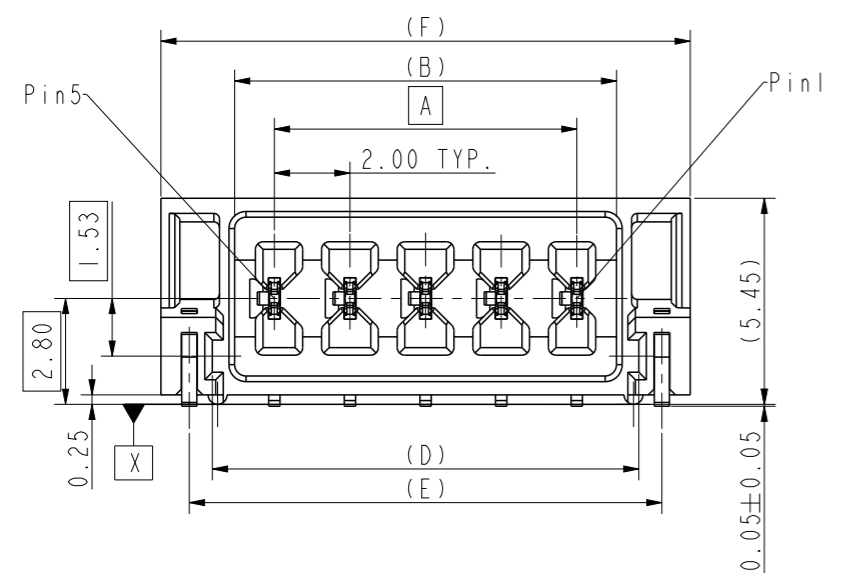
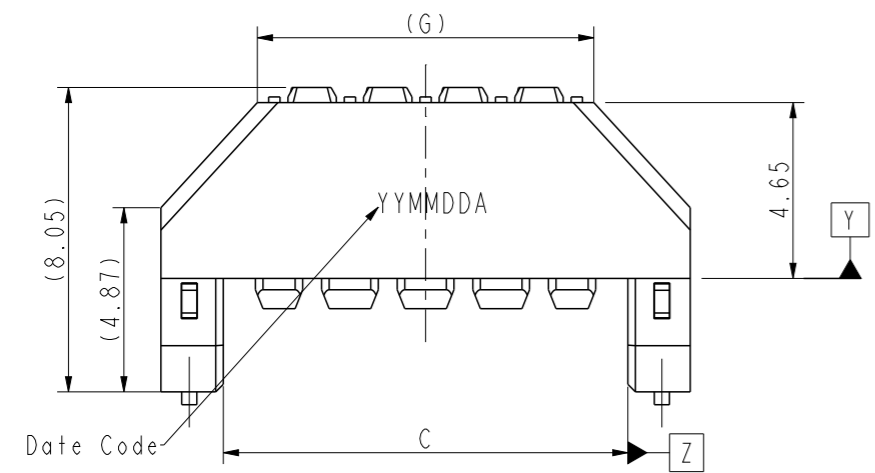

spec ref	-	dr	Nick Zhang	2019/02/02	projection	mm	size	A3	scale	5:1
tolerance std	ISO 406 ISO 1101	eng	Nick Zhang	2020/05/21			ecn no	ELX-N-37108-1		
surface	linear	chr	-	apppr			Tim Yao	2020/05/21	product family	-
	angular	0°	±1°	<b>Amphenol FCI</b>		title Cross-Mate 2.0PH Series Board Connector WTb 2.0 PITCH R/A -SMT TYPE Receptacle		cat. no. -	Product - Customer Drw	sheet 1 of 1