

TAS2770 Evaluation Module

This user's guide describes the characteristics, operation, and use of the *TAS2770EVM Reference Board*. A complete schematic diagram, printed-circuit board layouts, and bill of materials (BOM) are included in this document.

Contents

1	Export Control Notice.....	2
2	Description.....	2
3	Specifications.....	2
4	Software.....	2
5	Mono Setup.....	3
6	Multi-Channel Setup.....	6
7	Digital Audio Interfaces	7
8	Hardware Documentation	10

List of Figures

1	TAS2770EVM Stereo Configuration	3
2	Playback Device Settings.....	4
3	Texas Instruments Audio Control Panel	4
4	Multi-Channel Setup.....	6
5	USB Audio Input Configuration	8
6	AP or PSIA Input Configuration.....	9
7	Schematic: XMOS USB Controller.....	10
8	Schematic: Input Multiplexing and Level Shift.....	11
9	Schematic: External Input and Output Routing	12
10	Schematic: TAS2770 Channel 1 Control.....	13
11	Schematic: Onboard Power.....	14
12	PCB: Top Silkscreen.....	15
13	PCB: Top Solder Mask	16
14	PCB: Top Copper	17
15	PCB: Copper Layer 2.....	18
16	PCB: Copper Layer 3.....	19
17	PCB: Bottom Copper	20
18	PCB: Bottom Solder Mask	21
19	PCB: Bottom Silkscreen.....	22

List of Tables

1	Reference Board Specifications	2
2	Default Jumper Settings	5
3	TAS2770EVM Bill of Materials	23

Trademarks

PurePath is a trademark of Texas Instruments.
 Microsoft, Windows are registered trademarks of Microsoft Corporation.
 All other trademarks are the property of their respective owners.

1 Export Control Notice

Recipient agrees to not knowingly export or re-export, directly or indirectly, any product or technical data (as defined by the U.S., EU, and other Export Administration Regulations) including software, or any controlled product restricted by other applicable national regulations, received from disclosing party under nondisclosure obligations (if any), or any direct product of such technology, to any destination to which such export or re-export is restricted or prohibited by U.S. or other applicable laws, without obtaining prior authorization from U.S. Department of Commerce and other competent Government authorities to the extent required by those laws.

2 Description

The TAS2770 is a mono digital input Class-D audio amplifier optimized for efficiently driving high peak power into small loudspeakers. The Class-D amplifier is capable of delivering 18.3 W of peak power into a 4- Ω load while sustaining 1% THD+N at a battery voltage of 13.8 V. Integrated speaker voltage and current sense provides for real time monitoring of loudspeaker behavior. Up to eight devices can share a common bus via either I2S, TDM + I²C or SoundwireSM interfaces. Two PDM inputs are provided for low latency playback or sensor aggregation.

The TAS2770EVM supports evaluation and development with the TAS2770 device through the following interfaces:

- USB interface
 - TAS2770 control through PurePath™ Console 3 (PPC3) GUI, USB-HID
 - USB-class audio device, compatible with Microsoft® Windows® 7+
- Digital audio AP and PSIA interface through 100-mil headers
- I²C interface for TAS2770 control
- SoundwireSM interface for TAS2770 control

3 Specifications

Table 1 lists the reference board specifications.

Table 1. Reference Board Specifications

Amplifier power supply (VBAT)	4.5 to 16 V
EVM power supply	4.5 to 16 V
IO power supply (IOVDD)	1.65 to 1.95 V
Output power	18.3 W
USB, USB class-audio	Micro-USB B

4 Software

The TAS2770 EVM is easily configured with PurePath Console 3 running the TAS2770 plug-in.

NOTE: The evaluation driver currently distributed for use with this EVM will periodically inject a tone into the data stream. This is intentional behavior for this version of the driver. We are in the process of legal procurement of the full release version of this driver which will resolve this issue. Once available, it will be provided to the end user.

5 Mono Setup

Use the following steps for mono setup:

1. Install PurePath Console 3 with the TAS2770EVM plug-in.
2. Connect a speaker to J10 on the EVM. Alternatively, J20 and J15 can be used for speaker connections.
3. Attach a power supply to connector J9. There is also an alternate barrel jack connector (J19) adjacent to this connector.
4. Set jumper J13 to select the desired I²C address for channel 1.
5. Connect the EVM to a Windows 7+ PC with a micro-USB cable (J16).

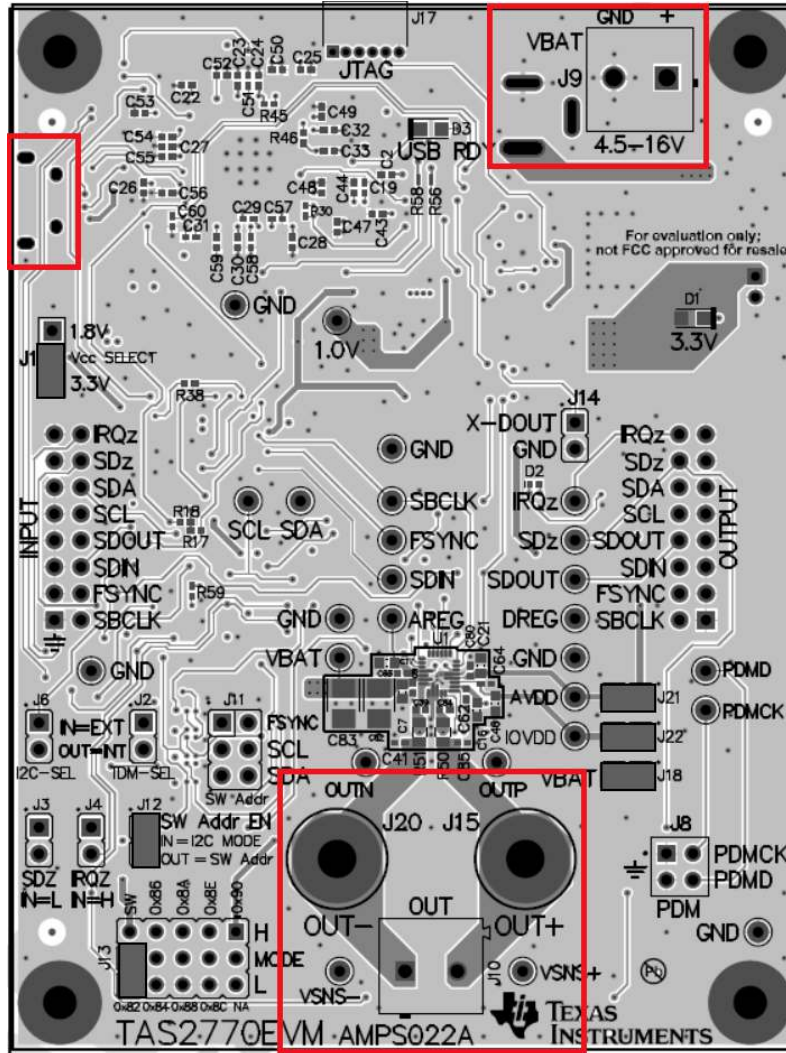

Figure 1. TAS2770EVM Stereo Configuration

- Verify that the EVM is the default playback device by opening the sound dialog from the *Windows Control Panel* as shown in [Figure 2](#).

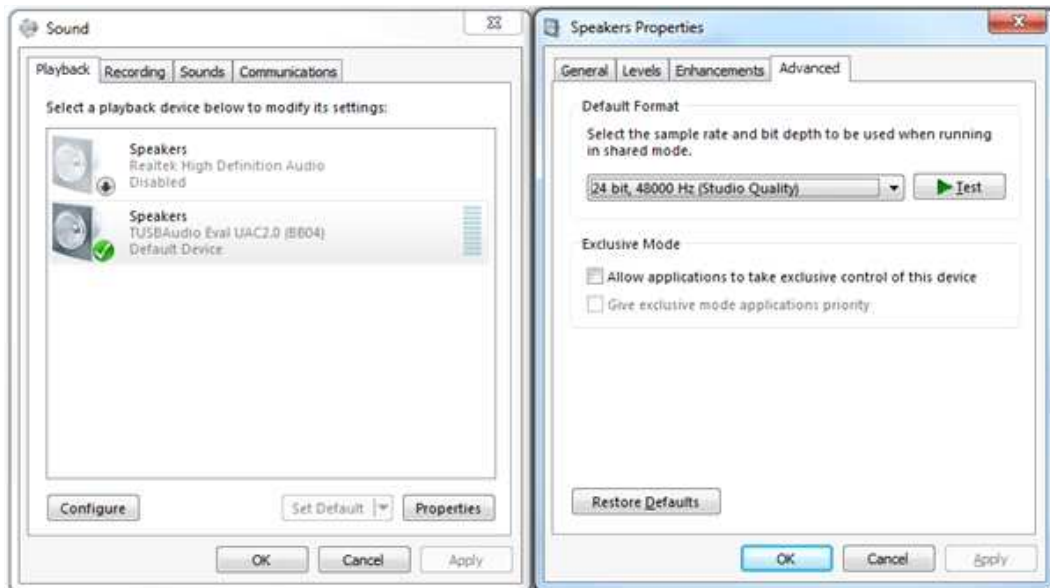

Figure 2. Playback Device Settings

- Set the sampling rate using the Windows setting by opening Properties > Advanced. The TAS2770EVM supports 44.1-kHz and 48-kHz sampling rates.
- Set the bit depth as desired using the *Texas Instruments USB Audio Control Panel* accessible from the system tray shown in [Figure 3](#).

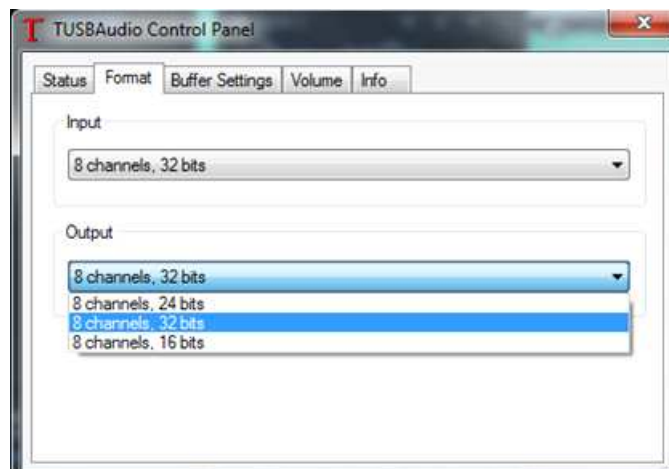

Figure 3. Texas Instruments Audio Control Panel

- Configure the device using PPC3.

Refer to [Table 2](#) for the default jumper settings.

Table 2. Default Jumper Settings

Jumper	Setting	Description
J1	3.3V	Selects I2S or TDM logic level
J2	Remove	Selects TDM input source
J6	Remove	Selects I ² C input source
J13	0x82	Selects I ² C address
J11	Remove	SoundWire address select
J21	Insert	AVDD connect
J22	Insert	IOVDD connect
J18	Insert	VBAT connect
J8	Remove	PDM inputs
J3	Remove	SDZ pulldown
J12	Insert	FSYNC/I2C Soundwire address enable
J4	Remove	IRQZ pullup
J14	Remove	3.3-V SDO _{UT}

6 Multi-Channel Setup

Use the following for multi-channel setup:

1. Install PurePath Console 3 with the TAS2770EVM plug-in.
2. Connect up to 8 TAS2770 EVMs together using connectors J5 and J7.
3. Attach a power supply to each board.
4. The leftmost board should have jumpers set to match the mono configuration. On all other boards, insert a jumper on J2 and J6. PPC3 will recognize 1, 2, 4, or 8 channel setups. See [Figure 4](#) for details.
5. Set Jumper J13 on each board to a unique address.
6. Verify that the EVM is the default playback device by opening the sound dialog from the *Windows Control Panel* as shown in [Figure 2](#).
7. Set the sampling rate using the Windows setting by opening Properties > Advanced. The TAS2770EVM supports 44.1-kHz and 48-kHz sampling rates.
8. Set the bit depth as desired using the *Texas Instruments USB Audio Control Panel* accessible from the system tray shown in [Figure 3](#).
9. Configure the device using PPC3.
10. Connect the leftmost EVM to a Windows 7+ PC with a micro-USB cable (J16).

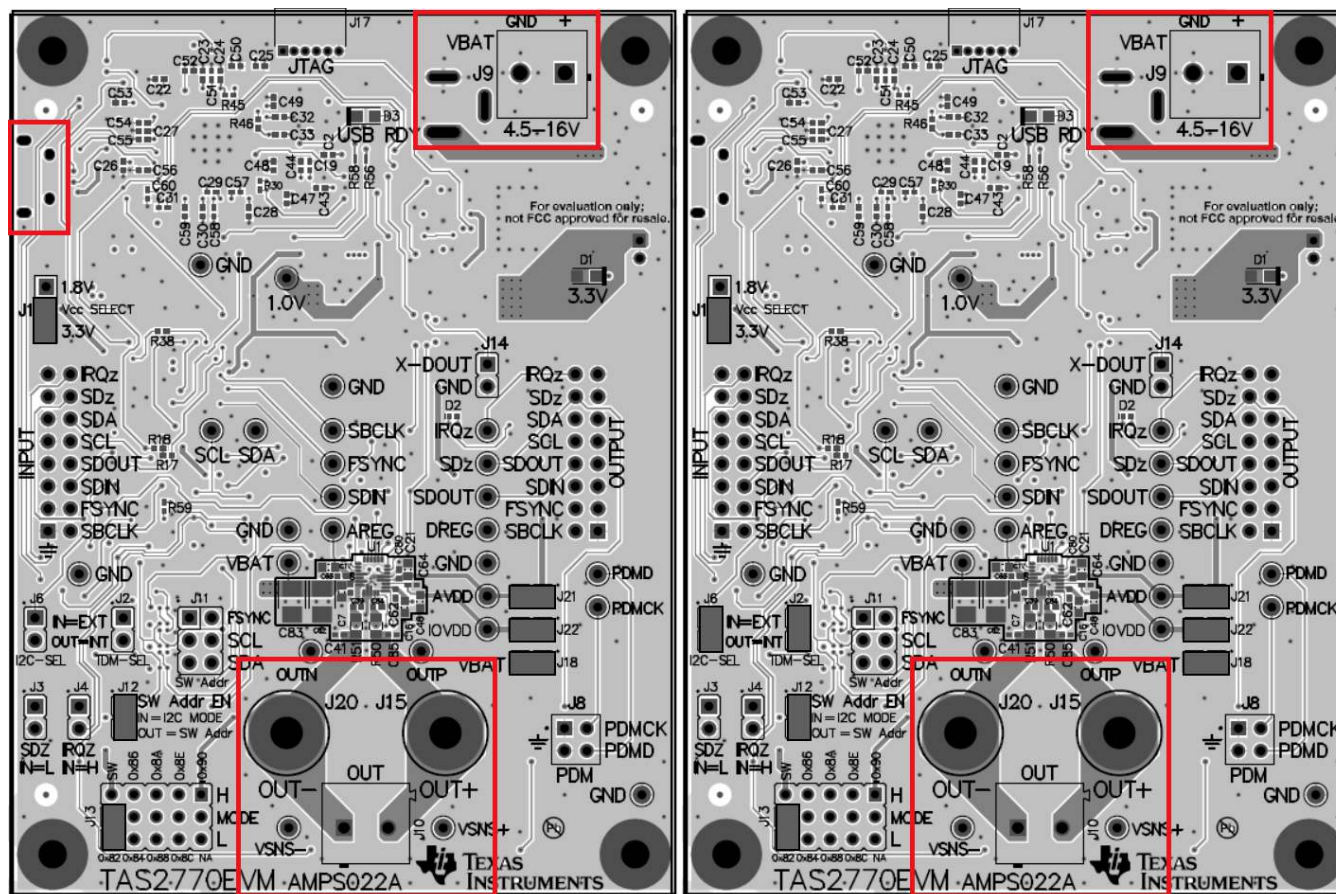

Figure 4. Multi-Channel Setup

7 Digital Audio Interfaces

Select the various digital audio interfaces on the *TAS2770EVM Reference Board* through hardware settings and software settings. Several headers close to the TAS2770 device allow access to the following digital audio signals:

- I2S Data out (SDOUT) from the TAS2770 (for example, current and voltage sense data)
- I2S Data in (SDIN) to the TAS2770
- I2S Word clock or frame sync (FSYNC)
- I2S Bit clock (SBCLK)
- PDM Clock (PDMCLK0) – optional input source for TAS2770
- PDM Clock (PDMCLK1) – optional input source for TAS2770
- PDM Data (PDM D0) – optional input source for TAS2770
- PDM Data (PDM D1) – optional input source for TAS2770
- I²C Clock (SCLK)
- I²C Data (SDA)

The TAS2770 device can also be configured for SoundwireSM Mode:

- SoundwireSM clock - SBCLK
- SoundwireSM data - SDOUT
- SoundwireSM address – SDA
- SoundwireSM address – FSYNC
- SoundwireSM address – SCL

A jumper inserted in the SW slot of J13 sets the TAS2770 to SoundwireSM mode. Then J11 can be set as desired to configure the device address.

The selection between USB (internal) and external inputs is controlled by jumpers J2 and J6. These jumpers set TDM and I²C, respectively.

7.1 Digital Audio Interface Selection

7.1.1 USB

The *TAS2770EVM Reference Board* contains an X MOS microcontroller that acts as a USB HID and USB-class audio interface. Select USB by removing J2 and J6, as [Figure 5](#) illustrates.

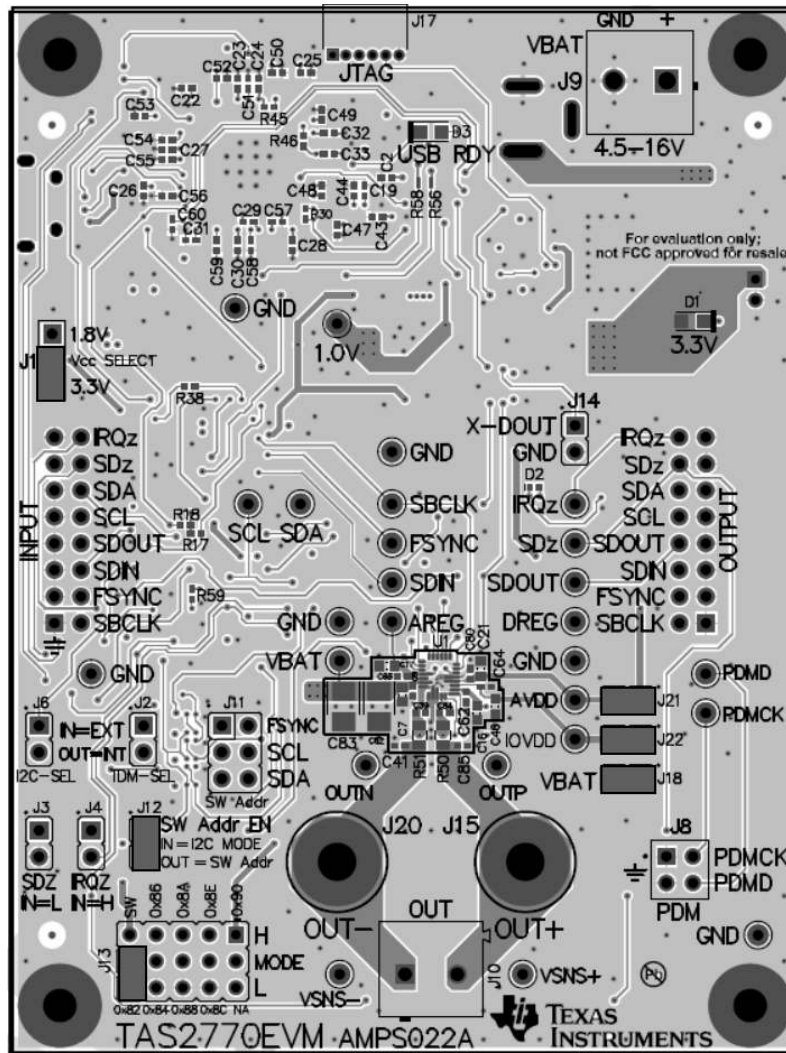

Figure 5. USB Audio Input Configuration

7.1.2 Direct (AP or PSIA)

Insert a jumper on J2 and connect the external digital audio source (for example AP or PSIA) to the external input header pin. The odd numbered pins on this header provide a ground for each signal, as Figure 6 shows. Note that the jumper setting for J1 must reflect the logic level of the external source.

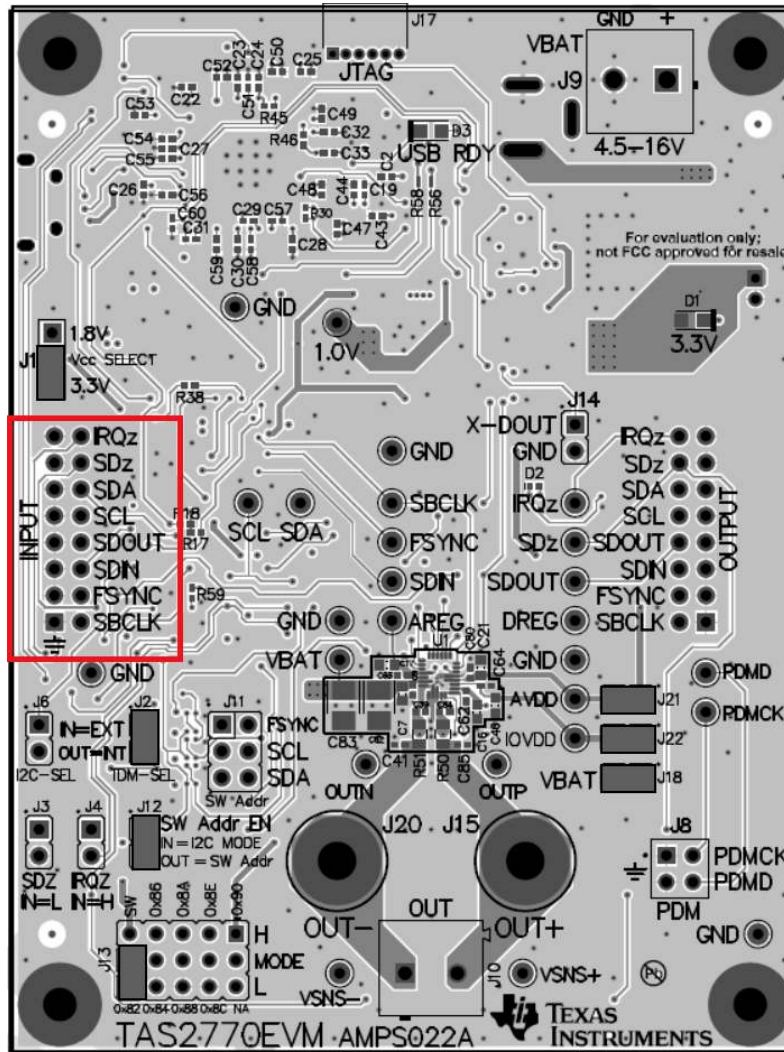
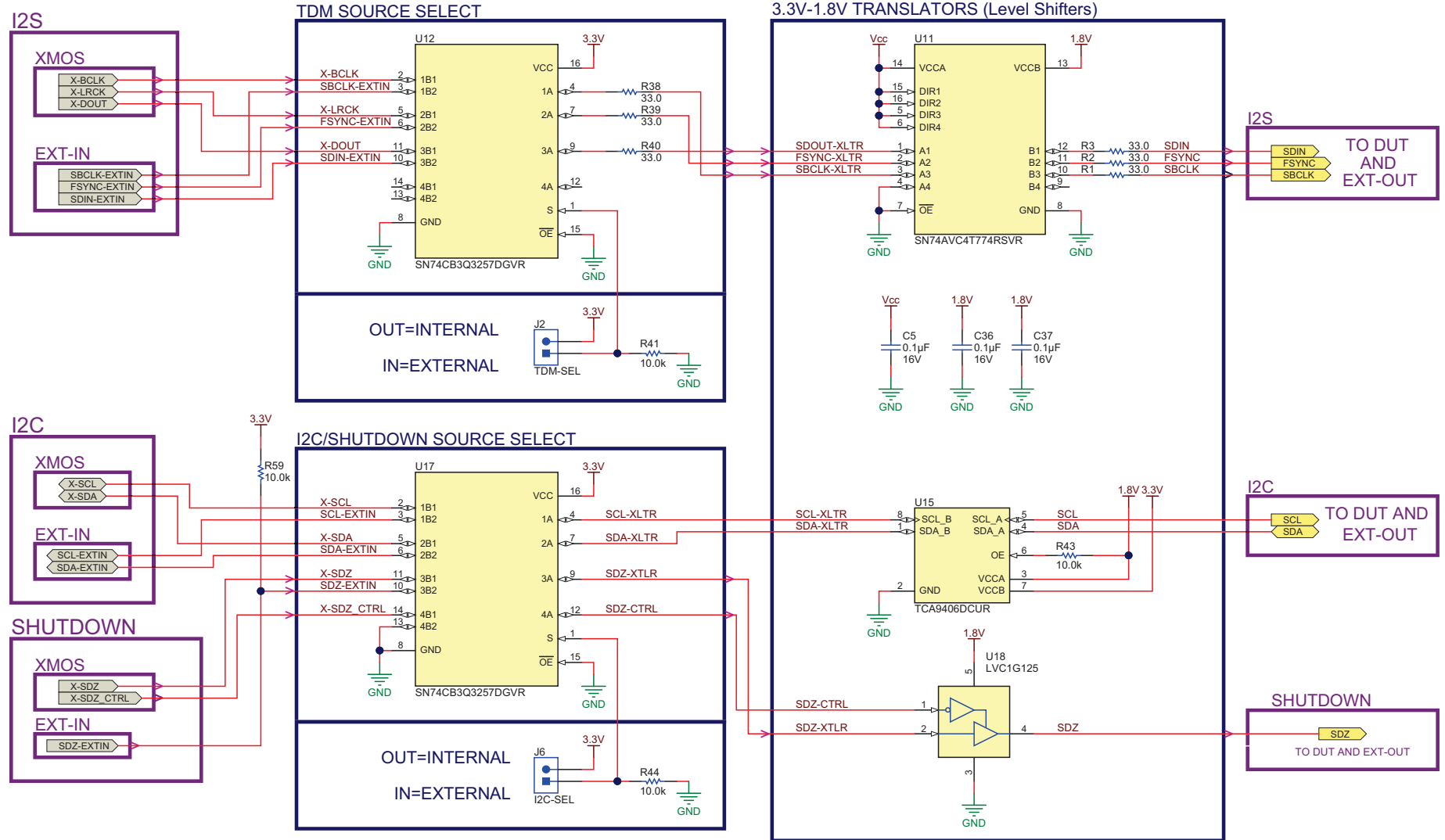
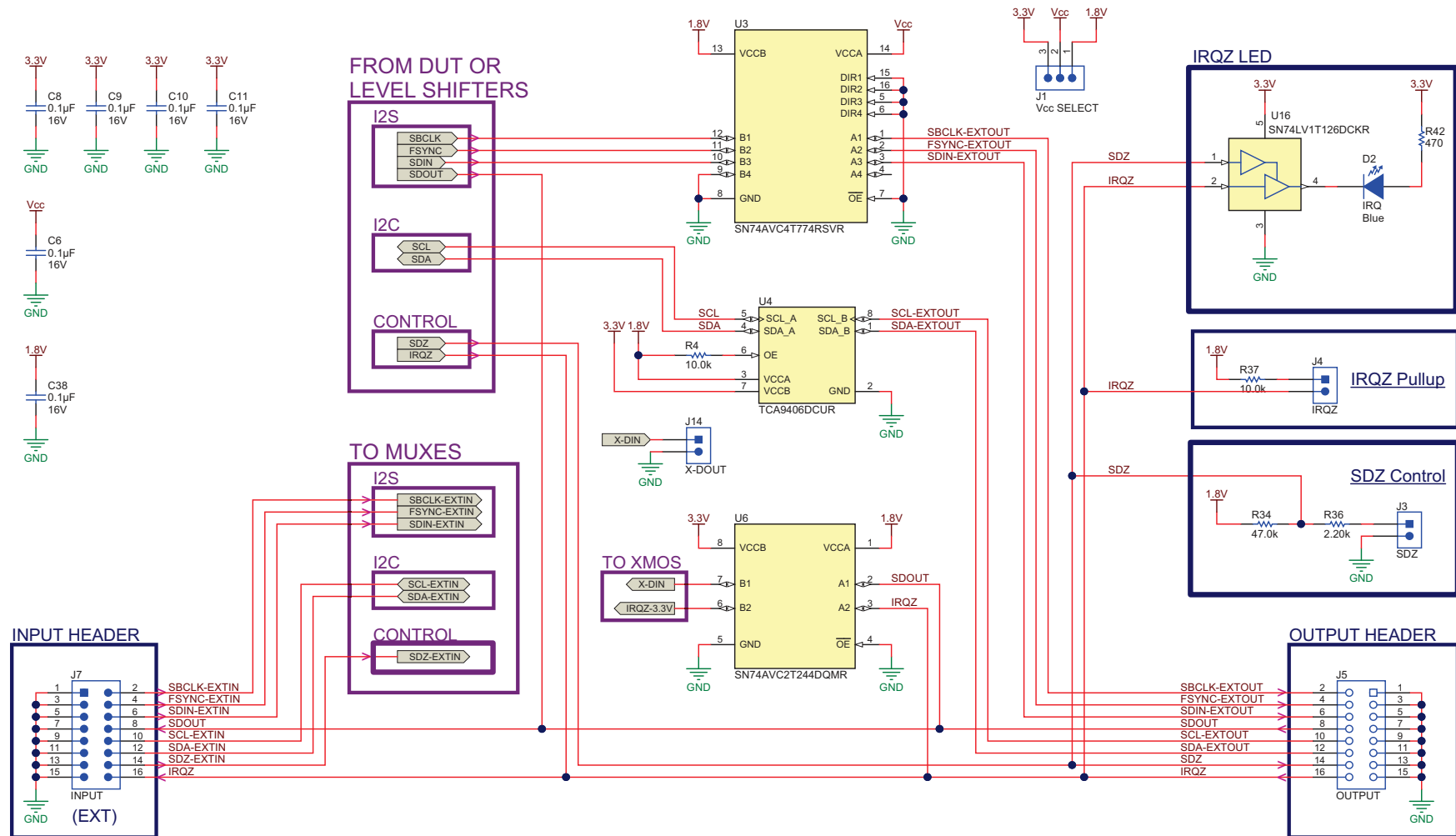

Figure 6. AP or PSIA Input Configuration



Copyright © 2017, Texas Instruments Incorporated

Figure 8. Schematic: Input Multiplexing and Level Shift



Copyright © 2017, Texas Instruments Incorporated

Figure 9. Schematic: External Input and Output Routing

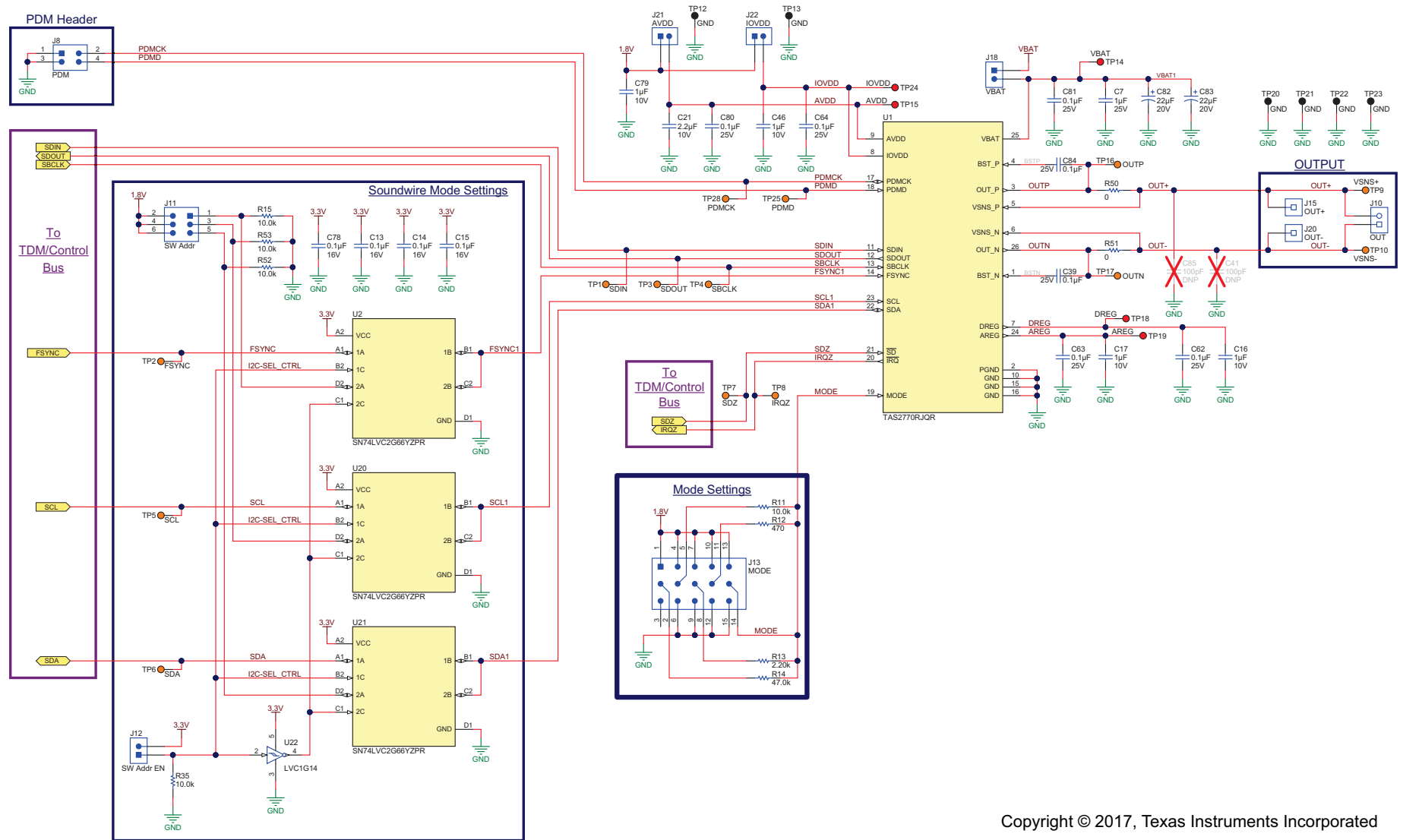

Copyright © 2017, Texas Instruments Incorporated

Figure 10. Schematic: TAS2770 Channel 1 Control

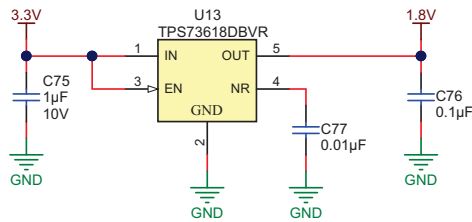
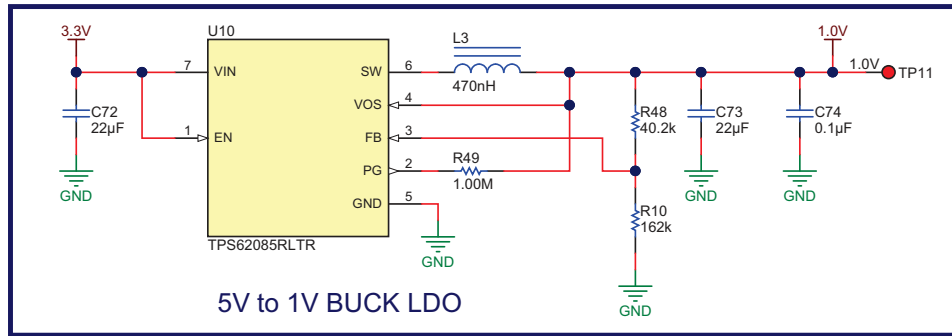
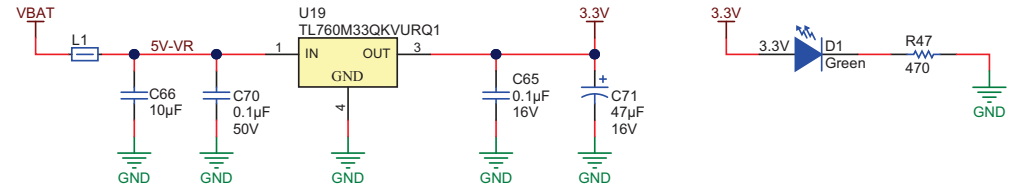
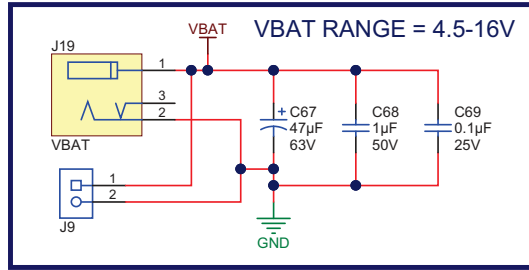

Copyright © 2017, Texas Instruments Incorporated

Figure 11. Schematic: Onboard Power

8.2 TAS2770EVM Reference Board Printed Circuit Board Layout

Figure 12 through Figure 19 show the PCB layout images.

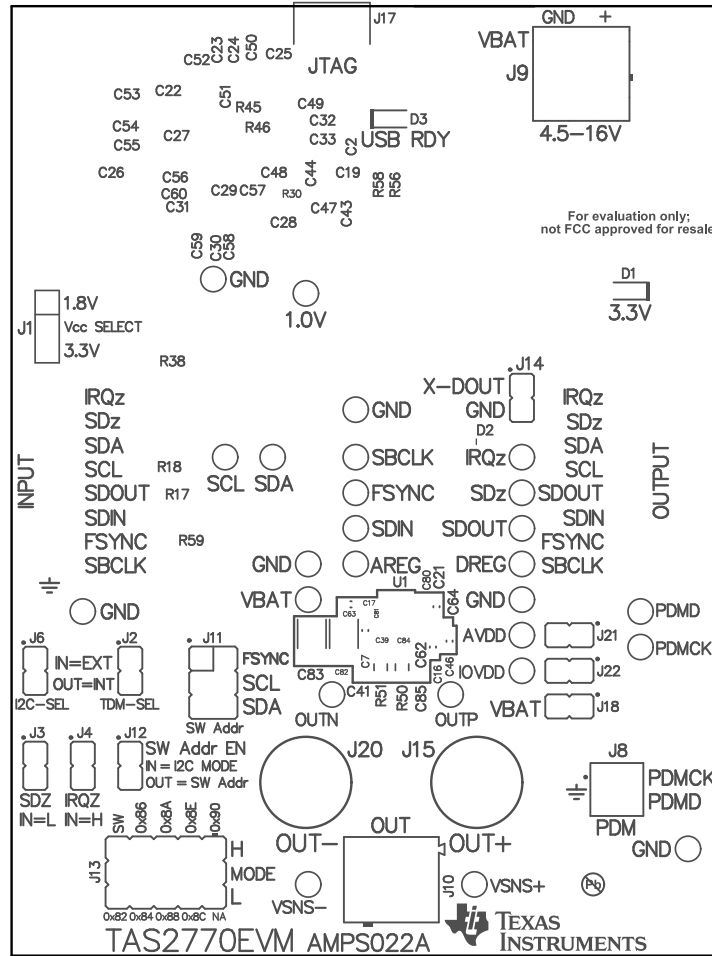

Figure 12. PCB: Top Silkscreen

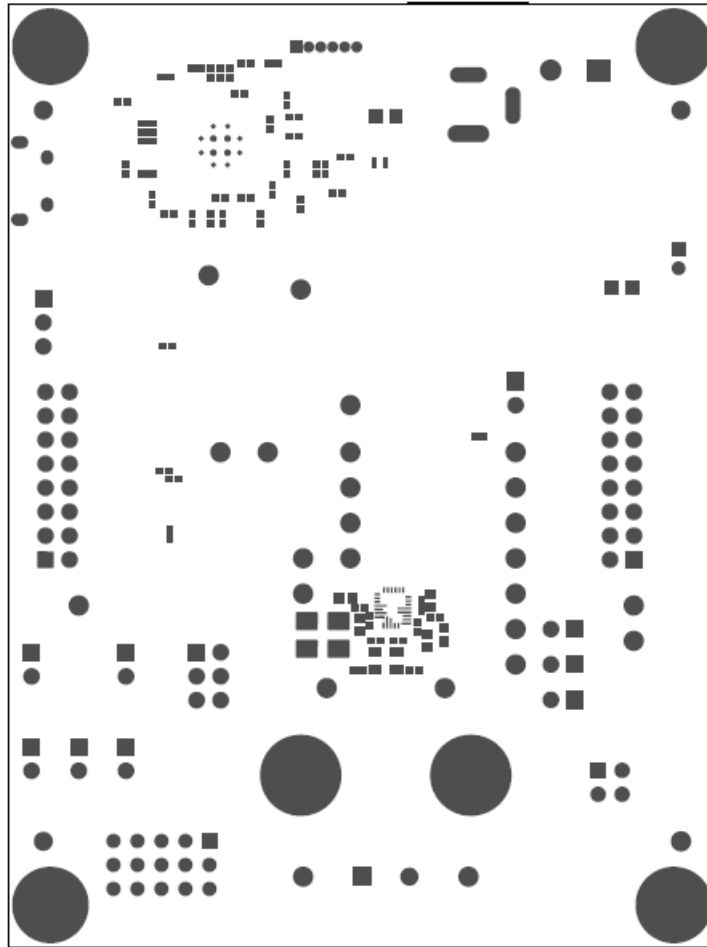

Figure 13. PCB: Top Solder Mask

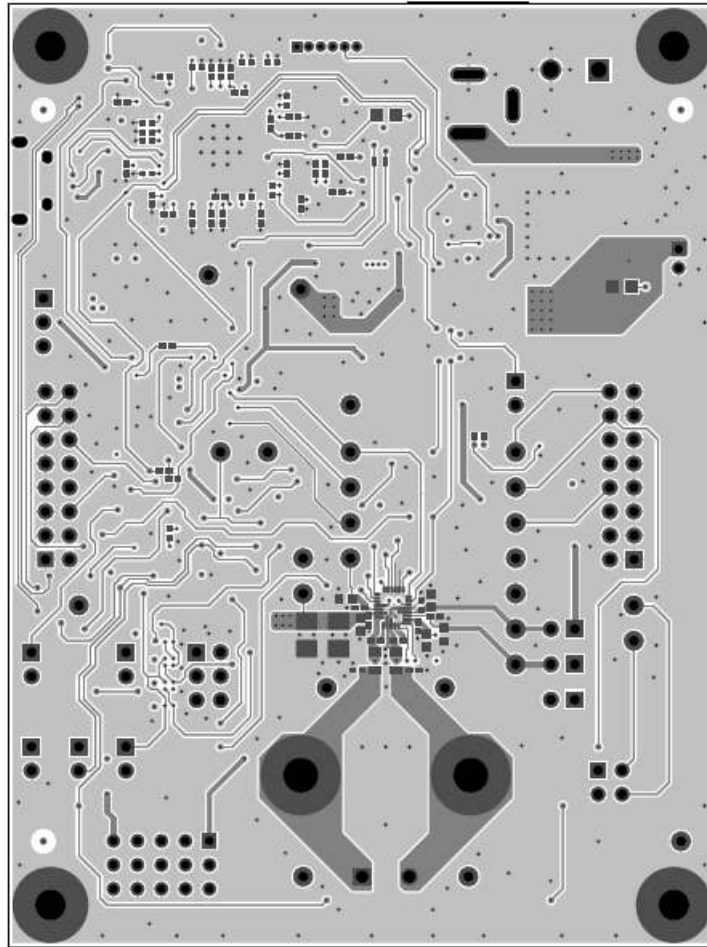

Figure 14. PCB: Top Copper

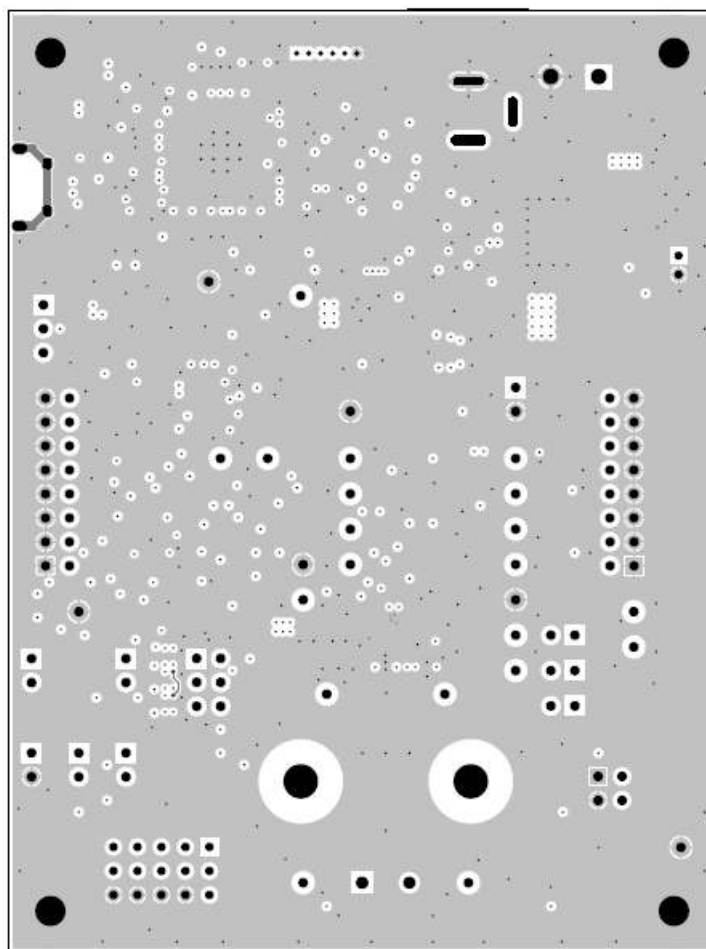

Figure 15. PCB: Copper Layer 2

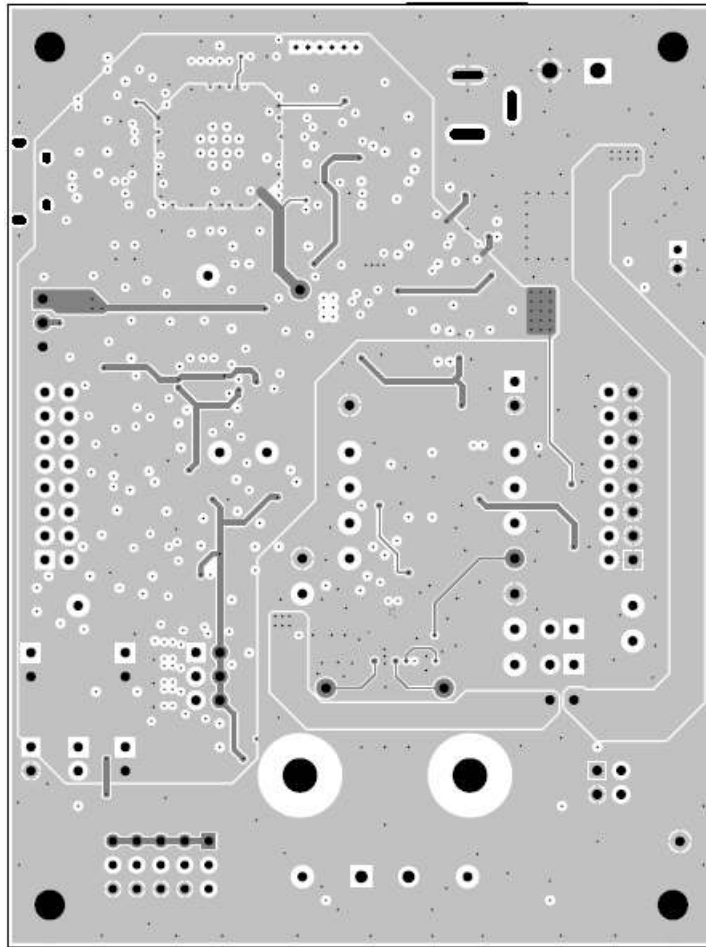

Figure 16. PCB: Copper Layer 3

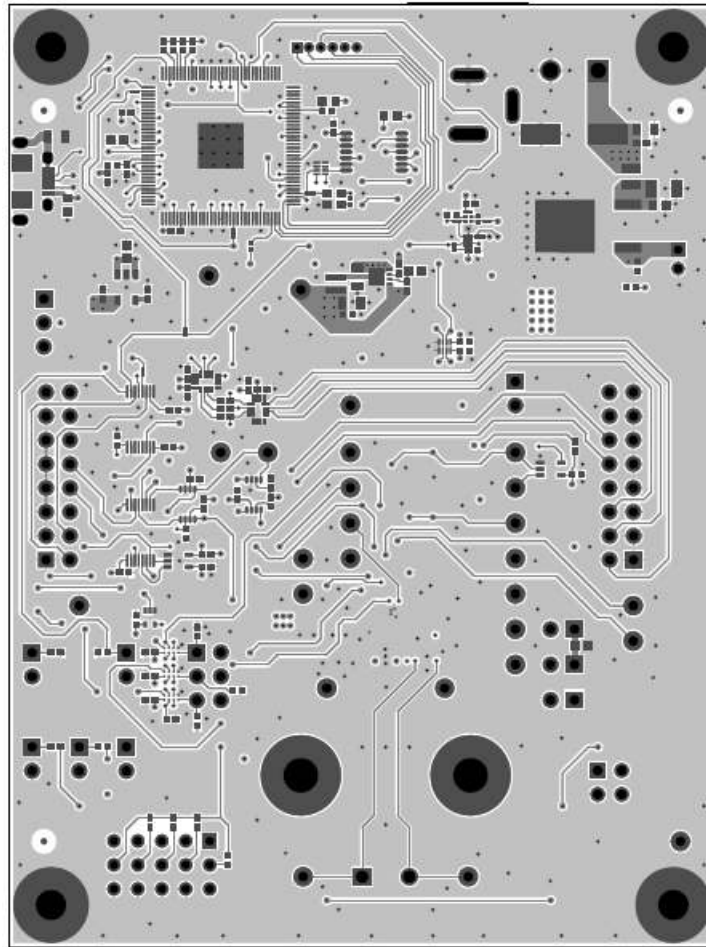

Figure 17. PCB: Bottom Copper

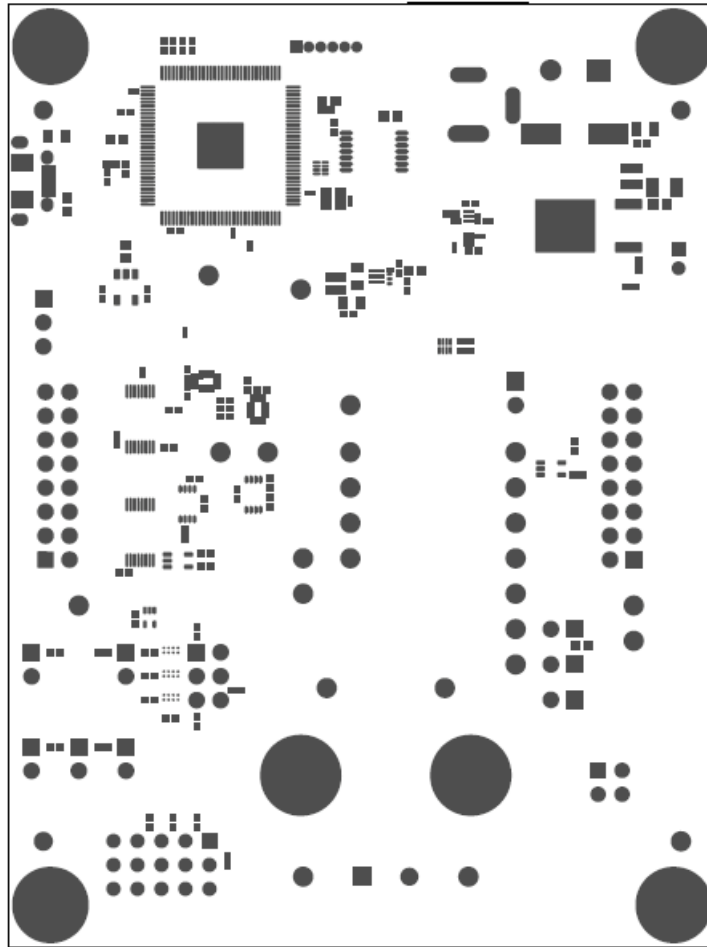

Figure 18. PCB: Bottom Solder Mask

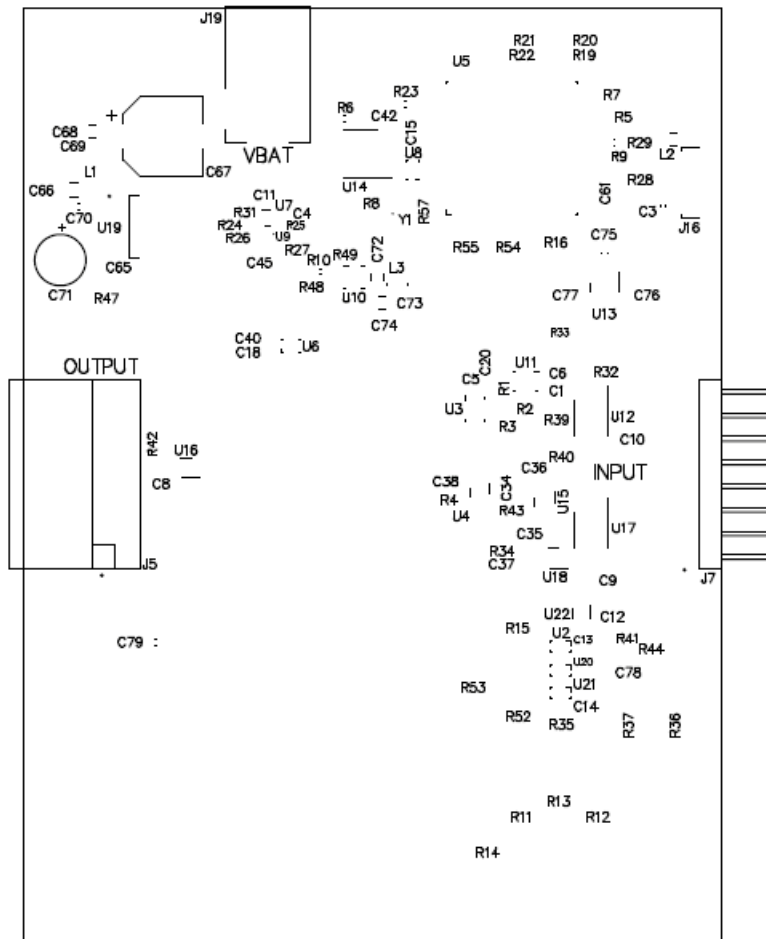

Figure 19. PCB: Bottom Silkscreen

8.3 TAS2770 Evaluation Board Bill of Materials

Table 3 displays the EVM BOM.

Table 3. TAS2770EVM Bill of Materials⁽¹⁾

Designator	QTY	Value	Description	Package Reference	Part Number	Manufacturer	Alternate Part Number	Alternate Manufacturer
IPC81	1		Printed Circuit Board		AMPS022	Any	-	-
C1, C2, C5, C6, C8, C9, C10, C11, C12, C13, C14, C15, C18, C19, C20, C22, C23, C24, C25, C26, C27, C28, C29, C30, C31, C32, C33, C34, C35, C36, C37, C38, C40, C43, C44, C45, C47, C48, C49, C50, C51, C52, C53, C54, C55, C56, C57, C58, C59, C60, C78	51	0.1uF	CAP, CERM, 0.1uF, 16V, ±10%, X7R, 0402	0402	GRM155R71C104KA88D	Murata		
C3	1	2.2uF	CAP, CERM, 2.2 µF, 10 V, ±10%, X7R, 0603	0603	GRM188R71A225KE15D	Murata		
C4	1	470pF	CAP, CERM, 470 pF, 25 V, ±5%, C0G/NP0, 0402	0402	GRM155C1E471JA01D	Murata		
C7	1	1uF	CAP, CERM, 1 µF, 25 V, ±10%, X5R, 0603	0603	GRM188R61E105KA12D	Murata		
C16, C17, C21, C46, C75, C79	6	1uF	CAP, CERM, 1 µF, 10 V, ±10%, X7R, 0603	0603	GRM188R71A105KA61D	Murata		
C39, C62, C63, C64, C69, C80, C81, C84	8	0.1uF	CAP, CERM, 0.1 µF, 25 V, ±20%, X7R, 0402	0402	C1005X7R1E104M050BB	TDK		
C42, C61, C65, C74	4	0.1uF	CAP, CERM, 0.1 µF, 16 V, ±10%, X7R, 0402	0402	GRM155R71C104KA88D	Murata		
C66	1	10uF	CAP, CERM, 10 µF, 35 V, ±10%, X7R, 1206	1206	GMK316AB7106KL	Taiyo Yuden		
C67	1	47uF	CAP, AL, 47 µF, 63 V, ±20%, 0.65 ohm, AEC-Q200 Grade 2, SMD	SMT Radial F	EEE-FK1J470P	Panasonic		
C68	1	1uF	CAP, CERM, 1 µF, 50 V, ±10%, X7R, 0805	0805	GRM21BR71H105KA12L	Murata		
C70	1	0.1uF	CAP, CERM, 0.1 µF, 50 V, ±10%, X7R, 0603	0603	GCM188R71H104KA57D	Murata		
C71	1	47uF	CAP, AL, 47 µF, 16 V, ±20%, 0.8 ohm, AEC-Q200 Grade 2, TH	D5xL11mm	EEU-FC1C470	Panasonic		
C72, C73	2	22uF	CAP, CERM, 22 µF, 10 V, ±20%, X7R, 0805	0805	GRM21B271A226ME15L	Murata		
C76	1	0.1uF	CAP, CERM, 0.1 µF, 10 V, ±10%, X7R, 0402	0402	GRM155R71A104KA01D	Murata		
C77	1	0.01uF	CAP, CERM, 0.01 µF, 6.3 V, ±10%, X7R, 0402	0402	GRM155R70J103KA01D	Murata		
C82, C83	2	22uF	CAP, Tantalum Polymer, 22 µF, 20 V, ±20%, 0.09 ohm, 3528-21 SMD	3528-21	TCJB226M020R0090	AVX		
D1	1	Green	LED, Green, SMD	LED_0805	LTST-C171GKT	Lite-On		
D2	1	Blue	LED, Blue, SMD	Blue LED	SMLP12BC7TT86	Rohm		
D3	1	Blue	LED, Blue, SMD	LED_0805	LTST-C170TBKT	Lite-On		
H1, H2, H3, H4	4		Machine Screw, Round, #4-40 x 1/4, Nylon, Philips panhead	Screw	NY PMS 440 0025 PH	B&F Fastener Supply		
H5, H6, H7, H8	4		Standoff, Hex, 0.5"L #4-40 Nylon	Standoff	1902C	Keystone	-	-
J1	1		Header, 100mil, 3x1, Gold, TH	PBC03SAAN	PBC03SAAN	Sullins Connector Solutions		
J2, J3, J4, J6, J12, J14, J18, J21, J22	9		Header, 100mil, 2x1, Gold, TH	Sullins 100mil, 1x2, 230 mil above insulator	PBC02SAAN	Sullins Connector Solutions		
J5	1		Receptacle, 100mil, 8x2, Gold, R/A, TH	SSQ-108-02-G-D-RA	SSQ-108-02-G-D-RA	Samtec		

⁽¹⁾ Unless otherwise noted in the *Alternate Part Number* or *Alternate Manufacturer* columns, all parts may be substituted

Table 3. TAS2770EVM Bill of Materials⁽¹⁾ (continued)

Designator	QTY	Value	Description	Package Reference	Part Number	Manufacturer	Alternate Part Number	Alternate Manufacturer
J7	1		Header, 100mil, 8x2, Gold, R/A, TH	8x2 R/A Header	TSW-108-08-G-D-RA	Samtec		
J8	1		Header, 100mil, 4x2, Tin, TH	Header, 4x2, 100mil, Tin	PEC04DAAN	Sullins Connector Solutions		
J9	1		Terminal Block, 5.08mm, 2x1, TH	Terminal Block, 5.08mm, 2x1, TH	0395443002	Molex		
J10	1		Terminal Block, 5 mm, 2x1, Tin, TH	Terminal Block, 5 mm, 2x1, TH	691 101 710 002	Würth Elektronik		
J11	1		Header, 100mil, 3x2, Gold, TH	Sullins 100mil, 2x3, 230 mil above insulator	PBC03DAAN	Sullins Connector Solutions		
J13	1		Header, 2.54mm, 5x3, Gold, TH	Header, 2.54mm, 5x3, TH	804-10-015-10-002000	Mill-Max		
J15	1		Binding Post, RED, TH	11.4x27.2mm	7006	Keystone		
J16	1		Connector, Receptacle, Micro-USB Type AB, R/A, Bottom Mount SMT	Connector, USB Micro AB	DX4R205JJAR1800	JAE Electronics		
J17	1		Receptacle, 50mil, 6x1, Gold, R/A, TH	6x1 Receptacle	LPPB061NGCN-RC	Sullins Connector Solutions		
J19	1		Power Jack, mini, 2.5mm OD, R/A, TH	Jack, 14.5x11x9mm	RAPC712X	Switchcraft		
J20	1		Binding Post, BLACK, TH	11.4x27.2mm	7007	Keystone		
L1	1	300 ohm	Ferrite Bead, 300 ohm @ 100 MHz, 3.1 A, 0806	0806	NFZ2MSM301SN10L	Murata		
L2	1	600 ohm	Ferrite Bead, 600 ohm @ 100MHz, 2A, 0805	0805	MPZ2012S601A	TDK		
L3	1	470nH	Inductor, Shielded Drum Core, Ferrite, 470 nH, 2 A, 0.059 ohm, SMD	Inductor, 2x1.2x2mm	VLS2012ET-R47N	TDK		
R1, R2, R3, R38, R39, R40	6	33.2	RES, 33.2, 1%, 0.063 W, 0402	0402	CRCW040233R2FKED	Vishay-Dale		
R4, R5, R43, R45, R46	5	10k	RES, 10 k, 5%, 0.063 W, 0402	0402	CRCW040210K0JNED	Vishay-Dale		
R6	1	680	RES, 680, 1%, 0.1 W, 0603	0603	RC0603FR-07680RL	Yageo America		
R7, R32, R33, R54, R55, R56, R57, R58	8	33.2	RES, 33.2, 1%, 0.05 W, 0201	0201	RC0201FR-0733R2L	Yageo America		
R8, R25, R26, R27	4	10.0k	RES, 10.0 k, 1%, 0.05 W, 0201	0201	CRCW020110K0FKED	Vishay-Dale		
R9	1	10.0k	RES, 10.0 k, 1%, 0.1 W, 0402	0402	ERJ-2RKF1002X	Panasonic		
R10	1	162k	RES, 162 k, 1%, 0.063 W, 0402	0402	CRCW0402162KFKED	Vishay-Dale		
R11, R15, R35, R37, R52, R53	6	10.0k	RES, 10.0 k, 1%, 0.063 W, 0402	0402	CRCW040210K0FKED	Vishay-Dale		
R12	1	470	RES, 470, 1%, 0.1 W, AEC-Q200 Grade 0, 0402	0402	ERJ-2RKF4700X	Panasonic		
R13, R17, R18, R36	4	2.2k	RES, 2.2 k, 5%, 0.063 W, 0402	0402	CRCW04022K0JNED	Vishay-Dale		
R14, R19, R20, R21, R22, R34	6	47k	RES, 47 k, 5%, 0.063 W, 0402	0402	CRCW040247K0JNED	Vishay-Dale		
R16	1	1.0k	RES, 1.0 k, 5%, 0.063 W, 0402	0402	CRCW04021K00JNED	Vishay-Dale		
R23	1	4.7	RES, 4.7, 5%, 0.1 W, 0603	0603	CRCW06034R70JNEA	Vishay-Dale		
R24	1	25.5k	RES, 25.5 k, 1%, 0.05 W, 0201	0201	RC0201FR-0725K5L	Yageo America		
R28	1	100k	RES, 100 k, 5%, 0.063 W, 0402	0402	CRCW0402100KJNED	Vishay-Dale		
R29	1	43.2	RES, 43.2, 1%, 0.063 W, 0402	0402	CRCW040243R2FKED	Vishay-Dale		
R30	1	0	RES, 0, 5%, 0.063 W, 0402	0402	CRCW04020000Z0ED	Vishay-Dale		
R31	1	51.0k	RES, 51.0 k, 1%, 0.05 W, 0201	0201	RC0201FR-0751KL	Yageo America		

Table 3. TAS2770EVM Bill of Materials⁽¹⁾ (continued)

Designator	QTY	Value	Description	Package Reference	Part Number	Manufacturer	Alternate Part Number	Alternate Manufacturer
R41, R44, R59	3	10.0k	RES, 10.0k ohm, 1%, 0.063W, 0402	0402	CRCW040210K0FKED	Vishay-Dale		
R42	1	360	RES, 360 ohm, 5%, 0.063W, 0402	0402	CRCW0402360RJNED	Vishay-Dale		
R47	1	360	RES, 360, 5%, 0.063 W, 0402	0402	CRCW0402360RJNED	Vishay-Dale		
R48	1	40.2k	RES, 40.2 k, 1%, 0.063 W, 0402	0402	CRCW040240K2FKED	Vishay-Dale		
R49	1	1.00Meg	RES, 1.00 M, 1%, 0.063 W, 0402	0402	CRCW04021M00FKED	Vishay-Dale		
R50, R51	2	0	RES, 0, 5%, 0.125 W, 0805	0805	RC0805JR-070RL	Yageo America		
SH1, SH2, SH3, SH4, SH5, SH6, SH7, SH8, SH9, SH10, SH11, SH12	12	1x2	Shunt, 100mil, Gold plated, Black	Shunt	969102-0000-DA	3M	SNT-100-BK-G	Samtec
TP1, TP2, TP3, TP4, TP5, TP6, TP7, TP8, TP9, TP10, TP16, TP17, TP25, TP26, TP27, TP28	16	Orange	Test Point, Miniature, Orange, TH	Orange Miniature Testpoint	5003	Keystone		
TP11, TP14, TP15, TP18, TP19, TP24	6		Test Point, Miniature, Red, TH	Red Miniature Testpoint	5000	Keystone		
TP12, TP13, TP20, TP21, TP22, TP23	6		Test Point, Miniature, Black, TH	Black Miniature Testpoint	5001	Keystone		
U1	1		TBD Data, VQFN26-RJQ	RJQ00026	TAS2770RJQ	Texas Instruments		Texas Instruments
U2, U20, U21	3		Dual Bilateral Analog Switch, YZP0008ADAD (DSBGA-8)	YZP0008ADAD	SN74LVC2G66YZPR	Texas Instruments		Texas Instruments
U3, U11	2		4-BIT DUAL-SUPPLY BUS TRANSCEIVER WITH CONFIGURABLE VOLTAGE TRANSLATION AND 3-STATE OUTPUTS, RSV0016A (UQFN-16)	RSV0016A	SN74AVC4T774RSVR	Texas Instruments		Texas Instruments
U4, U15	2		TCA9406 Dual Bidirectional 1-MHz I2C-BUS and SMBus Voltage Level-Translator, 1.65 to 3.6 V, -40 to 85 degC, 8-pin US8 (DCU), Green (RoHS & no Sb/Br)	DCU0008A	TCA9406DCUR	Texas Instruments	Equivalent	Texas Instruments
U5	1		IC MCU 512KB RAM, 128TQFP	TQFP-128	XEF216-512-TQ128-C20	XMOS semiconductor		
U6	1		Dual-Bit Dual-Supply Bus Transceiver, DQM0008A (X2SON-8)	DQM0008A	SN74AVC2T244DQMR	Texas Instruments		Texas Instruments
U7	1		Single-Channel, Adjustable Supervisory Circuit in Ultra-Small Package, DRY0006A (USON-6)	DRY0006A	TPS3897ADRYR	Texas Instruments	TPS3897ADRYT	Texas Instruments
U8	1		2-BIT UNIDIRECTIONAL VOLTAGE-LEVEL TRANSLATOR, DQM0008A (X2SON-8)	DQM0008A	SN74AVC2T244DQMR	Texas Instruments		Texas Instruments
U9	1		DUAL BUFFER/DRIVER WITH OPEN DRAIN OUTPUTS, DSF0006A	DSF0006A	SN74LVC2G07DSFR	Texas Instruments		Texas Instruments
U10	1		3-A Step-Down Converter with Hiccup Short Circuit Protection in 2x2 QFN Package, RLT0007A	RLT0007A	TPS62085RLTR	Texas Instruments	TPS62085RLTT	Texas Instruments
U12, U17	2		4-Bit 1-of-2 FET Multiplexer/Demultiplexer 2.5-V/3.3-V Low-Voltage High-Bandwidth Bus Switch, DGV0016A	DGV0016A	SN74CB3Q3257DGVR	Texas Instruments		Texas Instruments
U13	1		Single Output Low Noise LDO, 400 mA, Fixed 1.8 V Output, 1.7 to 5.5 V Input, with Reverse Current Protection, 5-pin SOT-23 (DBV), -40 to 85 degC, Green (RoHS & no Sb/Br)	DBV0005A	TPS73618DBVR	Texas Instruments	Equivalent	Texas Instruments
U14	1		Programmable 1-PLL VCXO Clock Synthesizer With 1.8-V, 2.5-V, and 3.3-V Outputs, PW0014A (TSSOP-14)	PW0014A	CDCE913PWR	Texas Instruments	CDCE913PW	Texas Instruments
U16	1		Single Power Supply Single Buffer Gate with 3-State Output CMOS Logic Level Shifter, DCK0005A	DCK0005A	SN74LV1T126DCKR	Texas Instruments		Texas Instruments
U18	1		Single Bus Buffer Gate With 3-State Output, DCK0005A (SOT-5)	DCK0005A	SN74LVC1G125DCKR	Texas Instruments	SN74LVC1G125DC KT	Texas Instruments

Table 3. TAS2770EVM Bill of Materials⁽¹⁾ (continued)

Designator	QTY	Value	Description	Package Reference	Part Number	Manufacturer	Alternate Part Number	Alternate Manufacturer
U19	1		Single Output Automotive LDO, 500 mA, Fixed 3.3 V Output, 3.8 to 26 V Input, 3-pin PFM (KVU), -40 to 125 degC, Green (RoHS & no Sb/Br)	KVU0003A	TL760M33QKVURQ1	Texas Instruments	Equivalent	Texas Instruments
U22	1		SINGLE SCHMITT-TRIGGER INVERTER, DRL0005A (SOT-5)	DRL0005A	SN74LVC1G14DRLR	Texas Instruments		Texas Instruments
Y1	1		OSC, 24 MHz, 2.25 - 3.63 V, SMD	2x1.6mm	ASTMLPA-24.000MHZ-EJ-E-T	Abracon Corporation		
C41, C85	0	100pF	CAP, CERM, 100 pF, 50 V, ±5%, C0G/NP0, 0402	0402	GRM1555C1H101JA01D	Murata		
FID1, FID2, FID3, FID4, FID5, FID6	0		Fiducial mark. There is nothing to buy or mount.	N/A	N/A	N/A		

STANDARD TERMS FOR EVALUATION MODULES

1. *Delivery:* TI delivers TI evaluation boards, kits, or modules, including any accompanying demonstration software, components, and/or documentation which may be provided together or separately (collectively, an "EVM" or "EVMs") to the User ("User") in accordance with the terms set forth herein. User's acceptance of the EVM is expressly subject to the following terms.
 - 1.1 EVMs are intended solely for product or software developers for use in a research and development setting to facilitate feasibility evaluation, experimentation, or scientific analysis of TI semiconductor products. EVMs have no direct function and are not finished products. EVMs shall not be directly or indirectly assembled as a part or subassembly in any finished product. For clarification, any software or software tools provided with the EVM ("Software") shall not be subject to the terms and conditions set forth herein but rather shall be subject to the applicable terms that accompany such Software
 - 1.2 EVMs are not intended for consumer or household use. EVMs may not be sold, sublicensed, leased, rented, loaned, assigned, or otherwise distributed for commercial purposes by Users, in whole or in part, or used in any finished product or production system.
2. *Limited Warranty and Related Remedies/Disclaimers:*
 - 2.1 These terms do not apply to Software. The warranty, if any, for Software is covered in the applicable Software License Agreement.
 - 2.2 TI warrants that the TI EVM will conform to TI's published specifications for ninety (90) days after the date TI delivers such EVM to User. Notwithstanding the foregoing, TI shall not be liable for a nonconforming EVM if (a) the nonconformity was caused by neglect, misuse or mistreatment by an entity other than TI, including improper installation or testing, or for any EVMs that have been altered or modified in any way by an entity other than TI, (b) the nonconformity resulted from User's design, specifications or instructions for such EVMs or improper system design, or (c) User has not paid on time. Testing and other quality control techniques are used to the extent TI deems necessary. TI does not test all parameters of each EVM. User's claims against TI under this Section 2 are void if User fails to notify TI of any apparent defects in the EVMs within ten (10) business days after delivery, or of any hidden defects with ten (10) business days after the defect has been detected.
 - 2.3 TI's sole liability shall be at its option to repair or replace EVMs that fail to conform to the warranty set forth above, or credit User's account for such EVM. TI's liability under this warranty shall be limited to EVMs that are returned during the warranty period to the address designated by TI and that are determined by TI not to conform to such warranty. If TI elects to repair or replace such EVM, TI shall have a reasonable time to repair such EVM or provide replacements. Repaired EVMs shall be warranted for the remainder of the original warranty period. Replaced EVMs shall be warranted for a new full ninety (90) day warranty period.
3. *Regulatory Notices:*
 - 3.1 *United States*
 - 3.1.1 *Notice applicable to EVMs not FCC-Approved:*

FCC NOTICE: This kit is designed to allow product developers to evaluate electronic components, circuitry, or software associated with the kit to determine whether to incorporate such items in a finished product and software developers to write software applications for use with the end product. This kit is not a finished product and when assembled may not be resold or otherwise marketed unless all required FCC equipment authorizations are first obtained. Operation is subject to the condition that this product not cause harmful interference to licensed radio stations and that this product accept harmful interference. Unless the assembled kit is designed to operate under part 15, part 18 or part 95 of this chapter, the operator of the kit must operate under the authority of an FCC license holder or must secure an experimental authorization under part 5 of this chapter.
 - 3.1.2 *For EVMs annotated as FCC – FEDERAL COMMUNICATIONS COMMISSION Part 15 Compliant:*

CAUTION

This device complies with part 15 of the FCC Rules. Operation is subject to the following two conditions: (1) This device may not cause harmful interference, and (2) this device must accept any interference received, including interference that may cause undesired operation.

Changes or modifications not expressly approved by the party responsible for compliance could void the user's authority to operate the equipment.

FCC Interference Statement for Class A EVM devices

NOTE: This equipment has been tested and found to comply with the limits for a Class A digital device, pursuant to part 15 of the FCC Rules. These limits are designed to provide reasonable protection against harmful interference when the equipment is operated in a commercial environment. This equipment generates, uses, and can radiate radio frequency energy and, if not installed and used in accordance with the instruction manual, may cause harmful interference to radio communications. Operation of this equipment in a residential area is likely to cause harmful interference in which case the user will be required to correct the interference at his own expense.

FCC Interference Statement for Class B EVM devices

NOTE: This equipment has been tested and found to comply with the limits for a Class B digital device, pursuant to part 15 of the FCC Rules. These limits are designed to provide reasonable protection against harmful interference in a residential installation. This equipment generates, uses and can radiate radio frequency energy and, if not installed and used in accordance with the instructions, may cause harmful interference to radio communications. However, there is no guarantee that interference will not occur in a particular installation. If this equipment does cause harmful interference to radio or television reception, which can be determined by turning the equipment off and on, the user is encouraged to try to correct the interference by one or more of the following measures:

- Reorient or relocate the receiving antenna.
- Increase the separation between the equipment and receiver.
- Connect the equipment into an outlet on a circuit different from that to which the receiver is connected.
- Consult the dealer or an experienced radio/TV technician for help.

3.2 Canada

3.2.1 For EVMs issued with an Industry Canada Certificate of Conformance to RSS-210 or RSS-247

Concerning EVMs Including Radio Transmitters:

This device complies with Industry Canada license-exempt RSSs. Operation is subject to the following two conditions:

(1) this device may not cause interference, and (2) this device must accept any interference, including interference that may cause undesired operation of the device.

Concernant les EVMs avec appareils radio:

Le présent appareil est conforme aux CNR d'Industrie Canada applicables aux appareils radio exempts de licence. L'exploitation est autorisée aux deux conditions suivantes: (1) l'appareil ne doit pas produire de brouillage, et (2) l'utilisateur de l'appareil doit accepter tout brouillage radioélectrique subi, même si le brouillage est susceptible d'en compromettre le fonctionnement.

Concerning EVMs Including Detachable Antennas:

Under Industry Canada regulations, this radio transmitter may only operate using an antenna of a type and maximum (or lesser) gain approved for the transmitter by Industry Canada. To reduce potential radio interference to other users, the antenna type and its gain should be so chosen that the equivalent isotropically radiated power (e.i.r.p.) is not more than that necessary for successful communication. This radio transmitter has been approved by Industry Canada to operate with the antenna types listed in the user guide with the maximum permissible gain and required antenna impedance for each antenna type indicated. Antenna types not included in this list, having a gain greater than the maximum gain indicated for that type, are strictly prohibited for use with this device.

Concernant les EVMs avec antennes détachables

Conformément à la réglementation d'Industrie Canada, le présent émetteur radio peut fonctionner avec une antenne d'un type et d'un gain maximal (ou inférieur) approuvé pour l'émetteur par Industrie Canada. Dans le but de réduire les risques de brouillage radioélectrique à l'intention des autres utilisateurs, il faut choisir le type d'antenne et son gain de sorte que la puissance isotrope rayonnée équivalente (p.i.r.e.) ne dépasse pas l'intensité nécessaire à l'établissement d'une communication satisfaisante. Le présent émetteur radio a été approuvé par Industrie Canada pour fonctionner avec les types d'antenne énumérés dans le manuel d'usage et ayant un gain admissible maximal et l'impédance requise pour chaque type d'antenne. Les types d'antenne non inclus dans cette liste, ou dont le gain est supérieur au gain maximal indiqué, sont strictement interdits pour l'exploitation de l'émetteur.

3.3 Japan

3.3.1 *Notice for EVMs delivered in Japan:* Please see http://www.tij.co.jp/lstds/ti_ja/general/eStore/notice_01.page 日本国内に輸入される評価用キット、ボードについては、次のところをご覧ください。
http://www.tij.co.jp/lstds/ti_ja/general/eStore/notice_01.page

3.3.2 *Notice for Users of EVMs Considered "Radio Frequency Products" in Japan:* EVMs entering Japan may not be certified by TI as conforming to Technical Regulations of Radio Law of Japan.

If User uses EVMs in Japan, not certified to Technical Regulations of Radio Law of Japan, User is required to follow the instructions set forth by Radio Law of Japan, which includes, but is not limited to, the instructions below with respect to EVMs (which for the avoidance of doubt are stated strictly for convenience and should be verified by User):

1. Use EVMs in a shielded room or any other test facility as defined in the notification #173 issued by Ministry of Internal Affairs and Communications on March 28, 2006, based on Sub-section 1.1 of Article 6 of the Ministry's Rule for Enforcement of Radio Law of Japan,
2. Use EVMs only after User obtains the license of Test Radio Station as provided in Radio Law of Japan with respect to EVMs, or
3. Use of EVMs only after User obtains the Technical Regulations Conformity Certification as provided in Radio Law of Japan with respect to EVMs. Also, do not transfer EVMs, unless User gives the same notice above to the transferee. Please note that if User does not follow the instructions above, User will be subject to penalties of Radio Law of Japan.

【無線電波を送信する製品の開発キットをお使いになる際の注意事項】 開発キットの中には技術基準適合証明を受けていないものがあります。技術適合証明を受けていないものご使用に際しては、電波法遵守のため、以下のいずれかの措置を取っていただく必要がありますのでご注意ください。

1. 電波法施行規則第6条第1項第1号に基づく平成18年3月28日総務省告示第173号で定められた電波暗室等の試験設備でご使用いただく。
2. 実験局の免許を取得後ご使用いただく。
3. 技術基準適合証明を取得後ご使用いただく。

なお、本製品は、上記の「ご使用にあたっての注意」を譲渡先、移転先に通知しない限り、譲渡、移転できないものとします。

上記を遵守頂けない場合は、電波法の罰則が適用される可能性があることをご留意ください。日本テキサス・インスツルメンツ株式会社

東京都新宿区西新宿 6 丁目 2 4 番 1 号
西新宿三井ビル

3.3.3 *Notice for EVMs for Power Line Communication:* Please see http://www.tij.co.jp/llds/ti_ja/general/eStore/notice_02.page
電力線搬送波通信についての開発キットをお使いになる際の注意事項については、次のところをご覧ください。 http://www.tij.co.jp/llds/ti_ja/general/eStore/notice_02.page

3.4 *European Union*

3.4.1 *For EVMs subject to EU Directive 2014/30/EU (Electromagnetic Compatibility Directive):*

This is a class A product intended for use in environments other than domestic environments that are connected to a low-voltage power-supply network that supplies buildings used for domestic purposes. In a domestic environment this product may cause radio interference in which case the user may be required to take adequate measures.

4 *EVM Use Restrictions and Warnings:*

4.1 EVMS ARE NOT FOR USE IN FUNCTIONAL SAFETY AND/OR SAFETY CRITICAL EVALUATIONS, INCLUDING BUT NOT LIMITED TO EVALUATIONS OF LIFE SUPPORT APPLICATIONS.

4.2 User must read and apply the user guide and other available documentation provided by TI regarding the EVM prior to handling or using the EVM, including without limitation any warning or restriction notices. The notices contain important safety information related to, for example, temperatures and voltages.

4.3 *Safety-Related Warnings and Restrictions:*

4.3.1 User shall operate the EVM within TI's recommended specifications and environmental considerations stated in the user guide, other available documentation provided by TI, and any other applicable requirements and employ reasonable and customary safeguards. Exceeding the specified performance ratings and specifications (including but not limited to input and output voltage, current, power, and environmental ranges) for the EVM may cause personal injury or death, or property damage. If there are questions concerning performance ratings and specifications, User should contact a TI field representative prior to connecting interface electronics including input power and intended loads. Any loads applied outside of the specified output range may also result in unintended and/or inaccurate operation and/or possible permanent damage to the EVM and/or interface electronics. Please consult the EVM user guide prior to connecting any load to the EVM output. If there is uncertainty as to the load specification, please contact a TI field representative. During normal operation, even with the inputs and outputs kept within the specified allowable ranges, some circuit components may have elevated case temperatures. These components include but are not limited to linear regulators, switching transistors, pass transistors, current sense resistors, and heat sinks, which can be identified using the information in the associated documentation. When working with the EVM, please be aware that the EVM may become very warm.

4.3.2 EVMs are intended solely for use by technically qualified, professional electronics experts who are familiar with the dangers and application risks associated with handling electrical mechanical components, systems, and subsystems. User assumes all responsibility and liability for proper and safe handling and use of the EVM by User or its employees, affiliates, contractors or designees. User assumes all responsibility and liability to ensure that any interfaces (electronic and/or mechanical) between the EVM and any human body are designed with suitable isolation and means to safely limit accessible leakage currents to minimize the risk of electrical shock hazard. User assumes all responsibility and liability for any improper or unsafe handling or use of the EVM by User or its employees, affiliates, contractors or designees.

4.4 User assumes all responsibility and liability to determine whether the EVM is subject to any applicable international, federal, state, or local laws and regulations related to User's handling and use of the EVM and, if applicable, User assumes all responsibility and liability for compliance in all respects with such laws and regulations. User assumes all responsibility and liability for proper disposal and recycling of the EVM consistent with all applicable international, federal, state, and local requirements.

5. *Accuracy of Information:* To the extent TI provides information on the availability and function of EVMs, TI attempts to be as accurate as possible. However, TI does not warrant the accuracy of EVM descriptions, EVM availability or other information on its websites as accurate, complete, reliable, current, or error-free.

6. *Disclaimers:*
- 6.1 EXCEPT AS SET FORTH ABOVE, EVMS AND ANY MATERIALS PROVIDED WITH THE EVM (INCLUDING, BUT NOT LIMITED TO, REFERENCE DESIGNS AND THE DESIGN OF THE EVM ITSELF) ARE PROVIDED "AS IS" AND "WITH ALL FAULTS." TI DISCLAIMS ALL OTHER WARRANTIES, EXPRESS OR IMPLIED, REGARDING SUCH ITEMS, INCLUDING BUT NOT LIMITED TO ANY EPIDEMIC FAILURE WARRANTY OR IMPLIED WARRANTIES OF MERCHANTABILITY OR FITNESS FOR A PARTICULAR PURPOSE OR NON-INFRINGEMENT OF ANY THIRD PARTY PATENTS, COPYRIGHTS, TRADE SECRETS OR OTHER INTELLECTUAL PROPERTY RIGHTS.
- 6.2 EXCEPT FOR THE LIMITED RIGHT TO USE THE EVM SET FORTH HEREIN, NOTHING IN THESE TERMS SHALL BE CONSTRUED AS GRANTING OR CONFERRING ANY RIGHTS BY LICENSE, PATENT, OR ANY OTHER INDUSTRIAL OR INTELLECTUAL PROPERTY RIGHT OF TI, ITS SUPPLIERS/LICENSORS OR ANY OTHER THIRD PARTY, TO USE THE EVM IN ANY FINISHED END-USER OR READY-TO-USE FINAL PRODUCT, OR FOR ANY INVENTION, DISCOVERY OR IMPROVEMENT, REGARDLESS OF WHEN MADE, CONCEIVED OR ACQUIRED.
7. *USER'S INDEMNITY OBLIGATIONS AND REPRESENTATIONS.* USER WILL DEFEND, INDEMNIFY AND HOLD TI, ITS LICENSORS AND THEIR REPRESENTATIVES HARMLESS FROM AND AGAINST ANY AND ALL CLAIMS, DAMAGES, LOSSES, EXPENSES, COSTS AND LIABILITIES (COLLECTIVELY, "CLAIMS") ARISING OUT OF OR IN CONNECTION WITH ANY HANDLING OR USE OF THE EVM THAT IS NOT IN ACCORDANCE WITH THESE TERMS. THIS OBLIGATION SHALL APPLY WHETHER CLAIMS ARISE UNDER STATUTE, REGULATION, OR THE LAW OF TORT, CONTRACT OR ANY OTHER LEGAL THEORY, AND EVEN IF THE EVM FAILS TO PERFORM AS DESCRIBED OR EXPECTED.
8. *Limitations on Damages and Liability:*
- 8.1 *General Limitations.* IN NO EVENT SHALL TI BE LIABLE FOR ANY SPECIAL, COLLATERAL, INDIRECT, PUNITIVE, INCIDENTAL, CONSEQUENTIAL, OR EXEMPLARY DAMAGES IN CONNECTION WITH OR ARISING OUT OF THESE TERMS OR THE USE OF THE EVMS , REGARDLESS OF WHETHER TI HAS BEEN ADVISED OF THE POSSIBILITY OF SUCH DAMAGES. EXCLUDED DAMAGES INCLUDE, BUT ARE NOT LIMITED TO, COST OF REMOVAL OR REINSTALLATION, ANCILLARY COSTS TO THE PROCUREMENT OF SUBSTITUTE GOODS OR SERVICES, RETESTING, OUTSIDE COMPUTER TIME, LABOR COSTS, LOSS OF GOODWILL, LOSS OF PROFITS, LOSS OF SAVINGS, LOSS OF USE, LOSS OF DATA, OR BUSINESS INTERRUPTION. NO CLAIM, SUIT OR ACTION SHALL BE BROUGHT AGAINST TI MORE THAN TWELVE (12) MONTHS AFTER THE EVENT THAT GAVE RISE TO THE CAUSE OF ACTION HAS OCCURRED.
- 8.2 *Specific Limitations.* IN NO EVENT SHALL TI'S AGGREGATE LIABILITY FROM ANY USE OF AN EVM PROVIDED HEREUNDER, INCLUDING FROM ANY WARRANTY, INDEMNITY OR OTHER OBLIGATION ARISING OUT OF OR IN CONNECTION WITH THESE TERMS, , EXCEED THE TOTAL AMOUNT PAID TO TI BY USER FOR THE PARTICULAR EVM(S) AT ISSUE DURING THE PRIOR TWELVE (12) MONTHS WITH RESPECT TO WHICH LOSSES OR DAMAGES ARE CLAIMED. THE EXISTENCE OF MORE THAN ONE CLAIM SHALL NOT ENLARGE OR EXTEND THIS LIMIT.
9. *Return Policy.* Except as otherwise provided, TI does not offer any refunds, returns, or exchanges. Furthermore, no return of EVM(s) will be accepted if the package has been opened and no return of the EVM(s) will be accepted if they are damaged or otherwise not in a resalable condition. If User feels it has been incorrectly charged for the EVM(s) it ordered or that delivery violates the applicable order, User should contact TI. All refunds will be made in full within thirty (30) working days from the return of the components(s), excluding any postage or packaging costs.
10. *Governing Law:* These terms and conditions shall be governed by and interpreted in accordance with the laws of the State of Texas, without reference to conflict-of-laws principles. User agrees that non-exclusive jurisdiction for any dispute arising out of or relating to these terms and conditions lies within courts located in the State of Texas and consents to venue in Dallas County, Texas. Notwithstanding the foregoing, any judgment may be enforced in any United States or foreign court, and TI may seek injunctive relief in any United States or foreign court.

IMPORTANT NOTICE FOR TI DESIGN INFORMATION AND RESOURCES

Texas Instruments Incorporated ("TI") technical, application or other design advice, services or information, including, but not limited to, reference designs and materials relating to evaluation modules, (collectively, "TI Resources") are intended to assist designers who are developing applications that incorporate TI products; by downloading, accessing or using any particular TI Resource in any way, you (individually or, if you are acting on behalf of a company, your company) agree to use it solely for this purpose and subject to the terms of this Notice.

TI's provision of TI Resources does not expand or otherwise alter TI's applicable published warranties or warranty disclaimers for TI products, and no additional obligations or liabilities arise from TI providing such TI Resources. TI reserves the right to make corrections, enhancements, improvements and other changes to its TI Resources.

You understand and agree that you remain responsible for using your independent analysis, evaluation and judgment in designing your applications and that you have full and exclusive responsibility to assure the safety of your applications and compliance of your applications (and of all TI products used in or for your applications) with all applicable regulations, laws and other applicable requirements. You represent that, with respect to your applications, you have all the necessary expertise to create and implement safeguards that (1) anticipate dangerous consequences of failures, (2) monitor failures and their consequences, and (3) lessen the likelihood of failures that might cause harm and take appropriate actions. You agree that prior to using or distributing any applications that include TI products, you will thoroughly test such applications and the functionality of such TI products as used in such applications. TI has not conducted any testing other than that specifically described in the published documentation for a particular TI Resource.

You are authorized to use, copy and modify any individual TI Resource only in connection with the development of applications that include the TI product(s) identified in such TI Resource. NO OTHER LICENSE, EXPRESS OR IMPLIED, BY ESTOPPEL OR OTHERWISE TO ANY OTHER TI INTELLECTUAL PROPERTY RIGHT, AND NO LICENSE TO ANY TECHNOLOGY OR INTELLECTUAL PROPERTY RIGHT OF TI OR ANY THIRD PARTY IS GRANTED HEREIN, including but not limited to any patent right, copyright, mask work right, or other intellectual property right relating to any combination, machine, or process in which TI products or services are used. Information regarding or referencing third-party products or services does not constitute a license to use such products or services, or a warranty or endorsement thereof. Use of TI Resources may require a license from a third party under the patents or other intellectual property of the third party, or a license from TI under the patents or other intellectual property of TI.

TI RESOURCES ARE PROVIDED "AS IS" AND WITH ALL FAULTS. TI DISCLAIMS ALL OTHER WARRANTIES OR REPRESENTATIONS, EXPRESS OR IMPLIED, REGARDING TI RESOURCES OR USE THEREOF, INCLUDING BUT NOT LIMITED TO ACCURACY OR COMPLETENESS, TITLE, ANY EPIDEMIC FAILURE WARRANTY AND ANY IMPLIED WARRANTIES OF MERCHANTABILITY, FITNESS FOR A PARTICULAR PURPOSE, AND NON-INFRINGEMENT OF ANY THIRD PARTY INTELLECTUAL PROPERTY RIGHTS.

TI SHALL NOT BE LIABLE FOR AND SHALL NOT DEFEND OR INDEMNIFY YOU AGAINST ANY CLAIM, INCLUDING BUT NOT LIMITED TO ANY INFRINGEMENT CLAIM THAT RELATES TO OR IS BASED ON ANY COMBINATION OF PRODUCTS EVEN IF DESCRIBED IN TI RESOURCES OR OTHERWISE. IN NO EVENT SHALL TI BE LIABLE FOR ANY ACTUAL, DIRECT, SPECIAL, COLLATERAL, INDIRECT, PUNITIVE, INCIDENTAL, CONSEQUENTIAL OR EXEMPLARY DAMAGES IN CONNECTION WITH OR ARISING OUT OF TI RESOURCES OR USE THEREOF, AND REGARDLESS OF WHETHER TI HAS BEEN ADVISED OF THE POSSIBILITY OF SUCH DAMAGES.

You agree to fully indemnify TI and its representatives against any damages, costs, losses, and/or liabilities arising out of your non-compliance with the terms and provisions of this Notice.

This Notice applies to TI Resources. Additional terms apply to the use and purchase of certain types of materials, TI products and services. These include; without limitation, TI's standard terms for semiconductor products (<http://www.ti.com/sc/docs/stdterms.htm>), [evaluation modules](#), and [samples](http://www.ti.com/sc/docs/sampterm.htm) (<http://www.ti.com/sc/docs/sampterm.htm>).

Mailing Address: Texas Instruments, Post Office Box 655303, Dallas, Texas 75265
Copyright © 2017, Texas Instruments Incorporated