

LOC		DIST		REVISIONS			
ES	00	P	LTN	DESCRIPTION	DATE	DWN	APVD
		G1		ADD NEW PART -19 AND -20	14JAN2015	AY	SZ

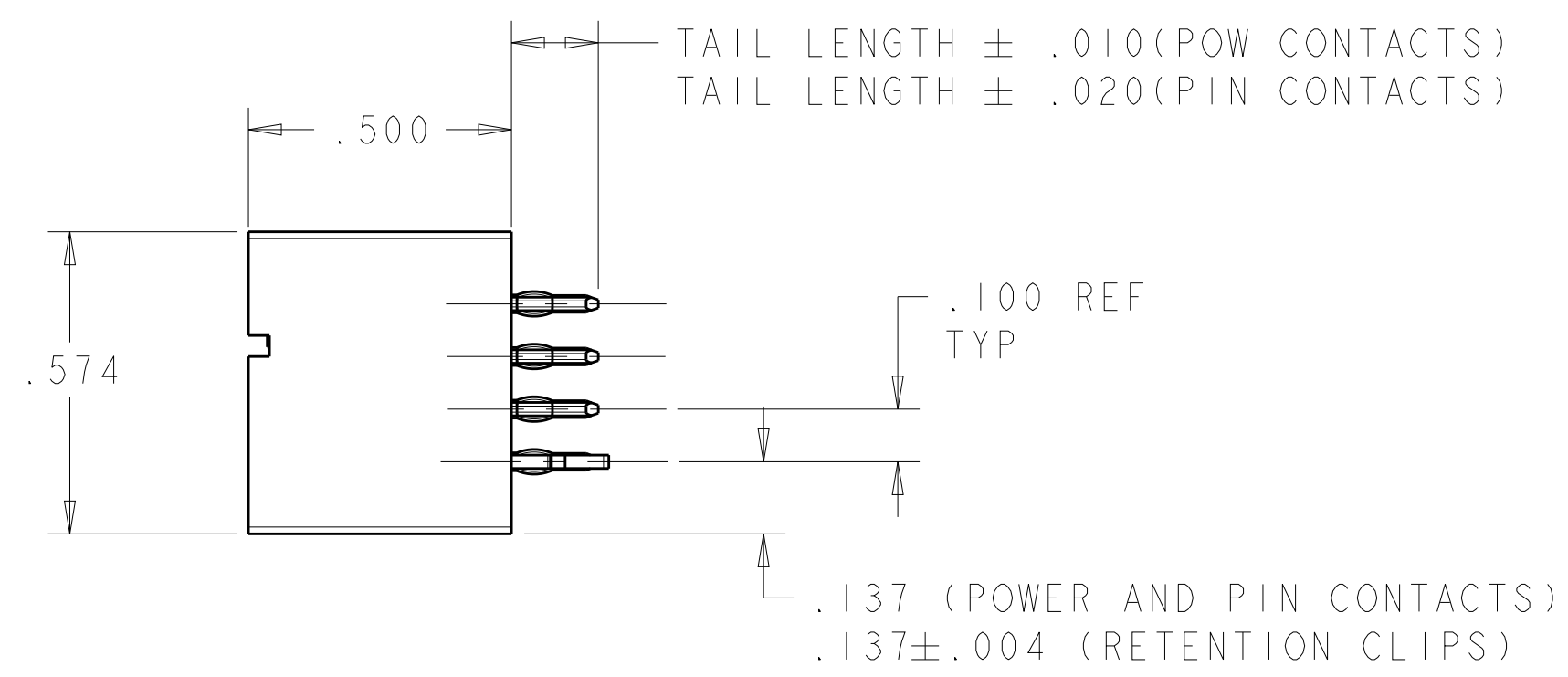
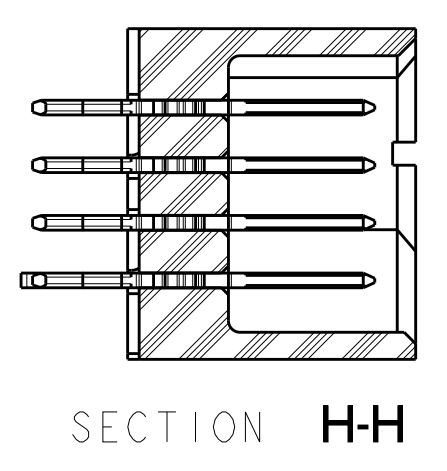
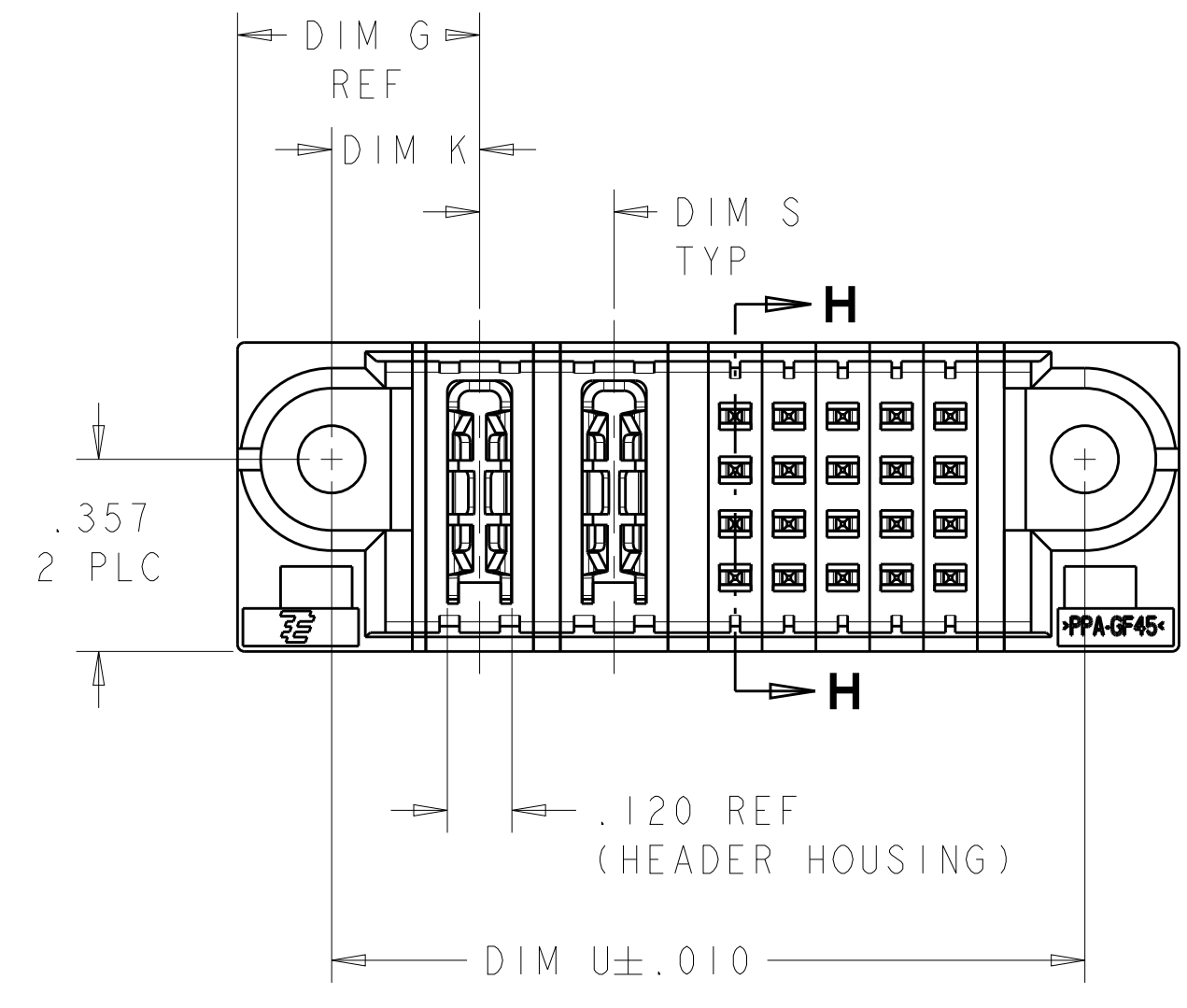
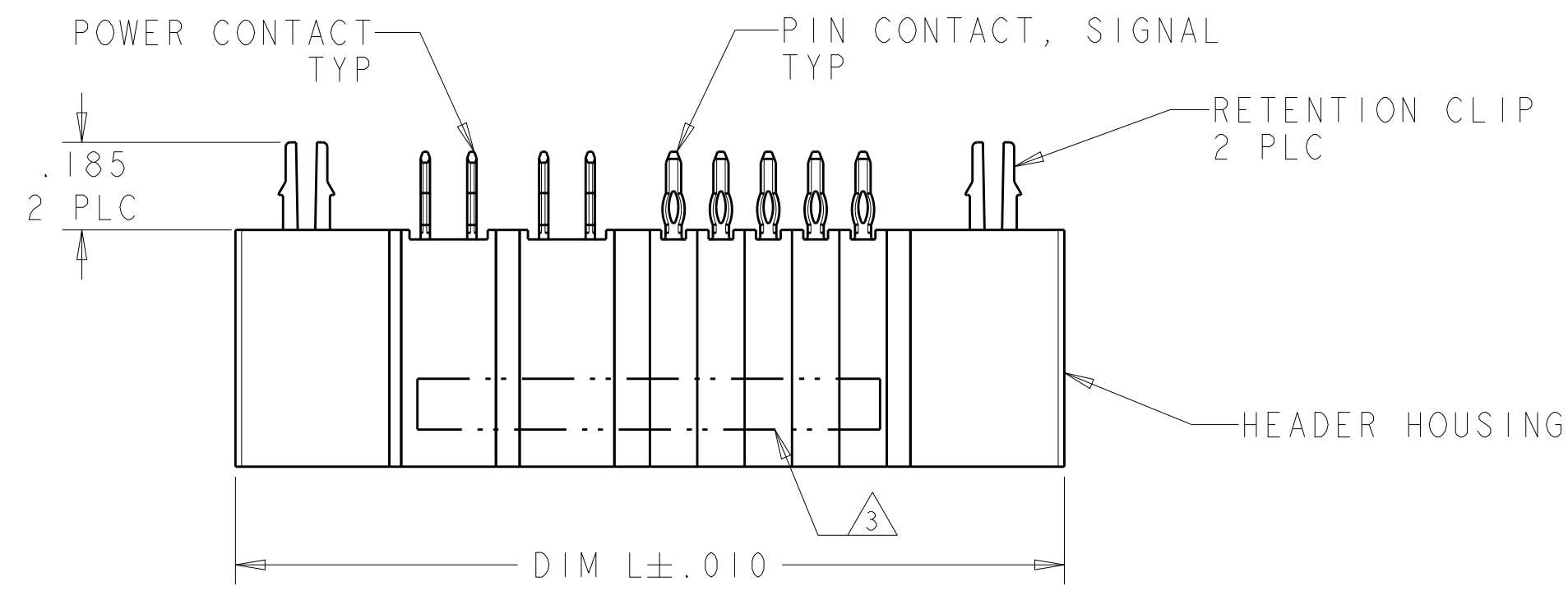
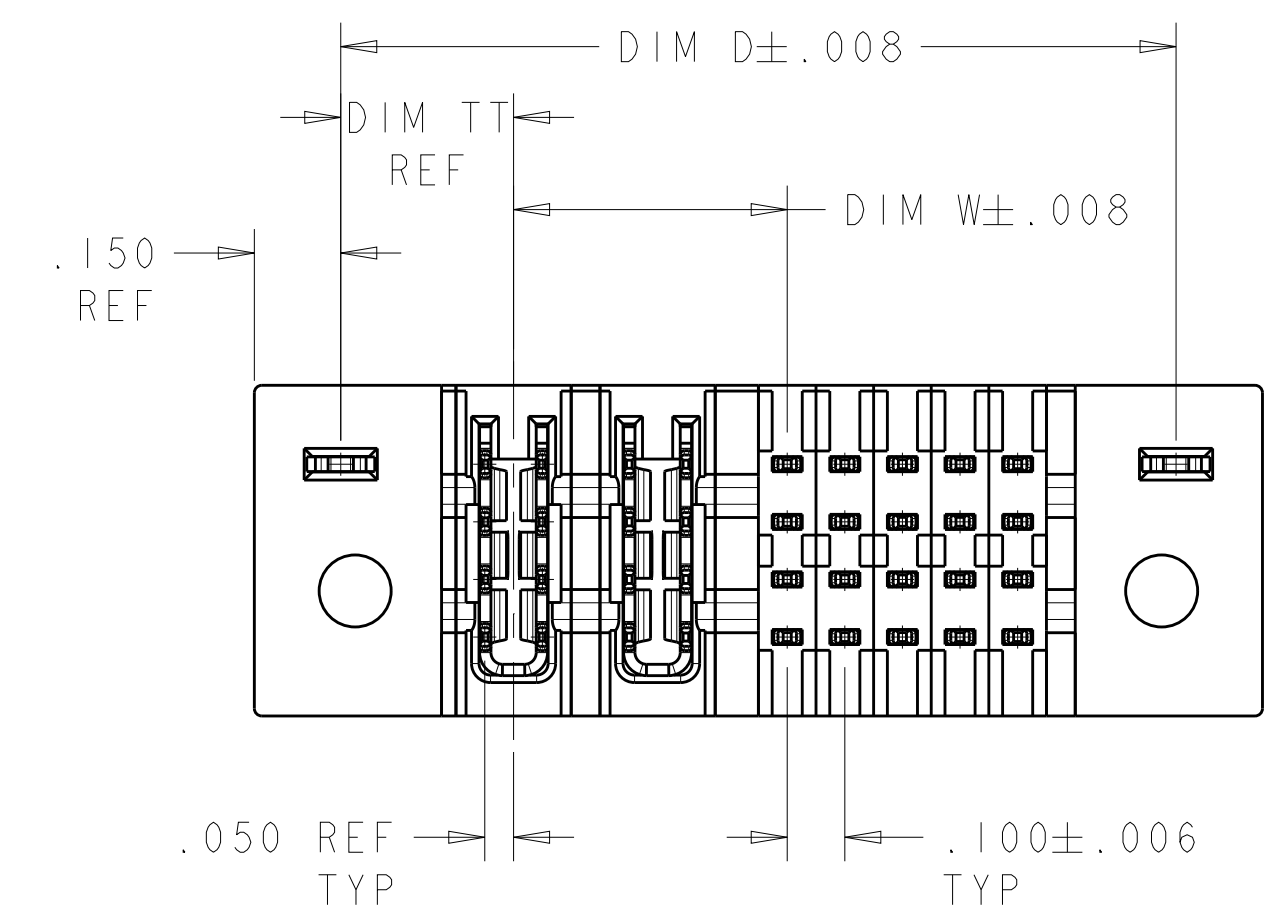

- ⚠️ HEADER HOUSING: THERMO PLASTIC, BLACK, UL94 V-O; CONTACTS AND RETENTION CLIPS: COPPER ALLOY.
- ⚠️ CONTACT PLATING: NOBLE METAL PLATING ON CONTACT FUNCTIONAL AREA OF POWER AND SIGNAL CONTACTS
RETENTION CLIP: .000115 MIN TIN.
- ⚠️ "AMP", PART NUMBER AND DATE CODE MARKED IN THIS AREA. PARTS UNDER 2.50 LONG MAY BE MARKED ON BOTH SIDES.
- ⚠️ DATUM AND BASIC DIMENSIONS ESTABLISHED BY CUSTOMER.
- ⚠️ PCB - ALL HOLE DIAMETERS ARE FINISHED HOLE SIZES.
- 6. A SEATING TOOL IS REQUIRED TO SEAT THE HEADER ON THE P.C. BOARD. PLEASE REFER TO THE 114-13038 APPLICATION SPEC.
- ⚠️ MECHANICAL CONNECTOR KEEP OUT ZONE.
- ⚠️ VARIABLE DIMENSION SHOWED ON TABLE SHEET.

-	-	.700	-	1.050	-	-	.750	NO	16S	2-6600313-0
.300	.925	1.500	.250	1.850	.275	.450	1.550	NO	4P + 8S	1-6600313-9
-	.425	3.100	.250	3.450	.275	.450	-	NO	2P + 92S	1-6600313-8
-	2.150	3.225	⚠️	3.575	.350	.525	-	NO	3ACP + 6P + 24S	1-6600313-7
.300	.925	1.800	.250	2.150	.275	.450	1.850	NO	4P + 20S	1-6600313-6
.300	.425	1.200	.250	1.550	.275	.450	1.250	YES	2P + 16S	1-6600313-5
.300	2.425	3.800	.250	4.150	.275	.450	3.850	YES	10P + 40S	1-6600313-4
.300	.975	1.650	.250	2.000	.275	.450	1.700	YES	4P + 12S	1-6600313-3
-	-	.600	-	.950	-	-	.650	YES	8S	1-6600313-2
.325	2.600	3.200	.300	3.550	.300	.475	3.250	YES	9ACP + 8S	1-6600313-1
.300	.925	1.500	.250	1.850	.275	.450	1.550	YES	4P + 8S	1-6600313-0
.275	1.800	2.400	.200	2.750	.250	.425	2.450	YES	9HDP + 8S	6600313-9
.300	1.375	1.850	.200	2.200	.275	.450	1.900	YES	7HDP + 4S	6600313-8
.325	1.825	2.825	⚠️	3.175	.300	.475	2.875	YES	3ACP + 4P + 24S	6600313-6
.325	1.500	2.250	.250	2.600	.300	.475	2.300	YES	6P + 12S	6600313-3
.300	.475	1.400	.250	1.750	.275	.450	1.450	YES	2P + 20S	6600313-2
DIM "TT"	DIM "W"	DIM "U"	DIM "S"	DIM "L"	DIM "K"	DIM "G"	DIM "D"	RETENTION CLIP	DESCRIPTION	PART NUMBER

DIMENSIONS: INCH 		TOLERANCES UNLESS OTHERWISE SPECIFIED: 0 PLC ±.1 2 PLC ±.05 3 PLC ±.005 4 PLC ±. ANGLES ±. FINISH		DWN J. McCLINTON 060CT05 CHK D. TROUT 060CT05 APVD B. MLYNE 060CT05 PRODUCT SPEC 108-1973 APPLICATION SPEC 114-13038 WEIGHT CUSTOMER DRAWING		Tyco Electronics Corporation Shanghai, P.R. China. 200233 NAME VERTICAL HEADER ASSEMBLY, W/GUIDES PRESS FIT, TYPE PS MULTI-BEAM XL SIZE CAGE CODE DRAWING NO A1100779C=6600313 SCALE 3:1 SHEET 1 OF 7 REV G1	
-------------------------	--	---------------------------------------------------------------------------------------------------------------------	--	----------------------------------------------------------------------------------------------------------------------------------------------------------------------	--	-----------------------------------------------------------------------------------------------------------------------------------------------------------------------------------------------------------------------------------	--

PART NUMBER	ROWS	POWER		SIGNAL					HD
		P1	P2	1	2	3	4	5	
6600313-2	D	VM	VM	EV	EV	EV	EV	EV	HD
	C			EV	EV	EV	EV		
	B			EV	EV	EV	EV		
	A			EV	EV	EV	EV		
2P+20S		HD							HD

PART NUMBER	ROWS	POWER							S	HD
		P1	P2	P3	P4	P5	P6	P7	I	
6600313-8	D	VM	VM	VM	VM	VM	VM	VM	EV	HD
	C								EV	
	B								EV	
	A								ES	
7HDP+4S		HD							HD	

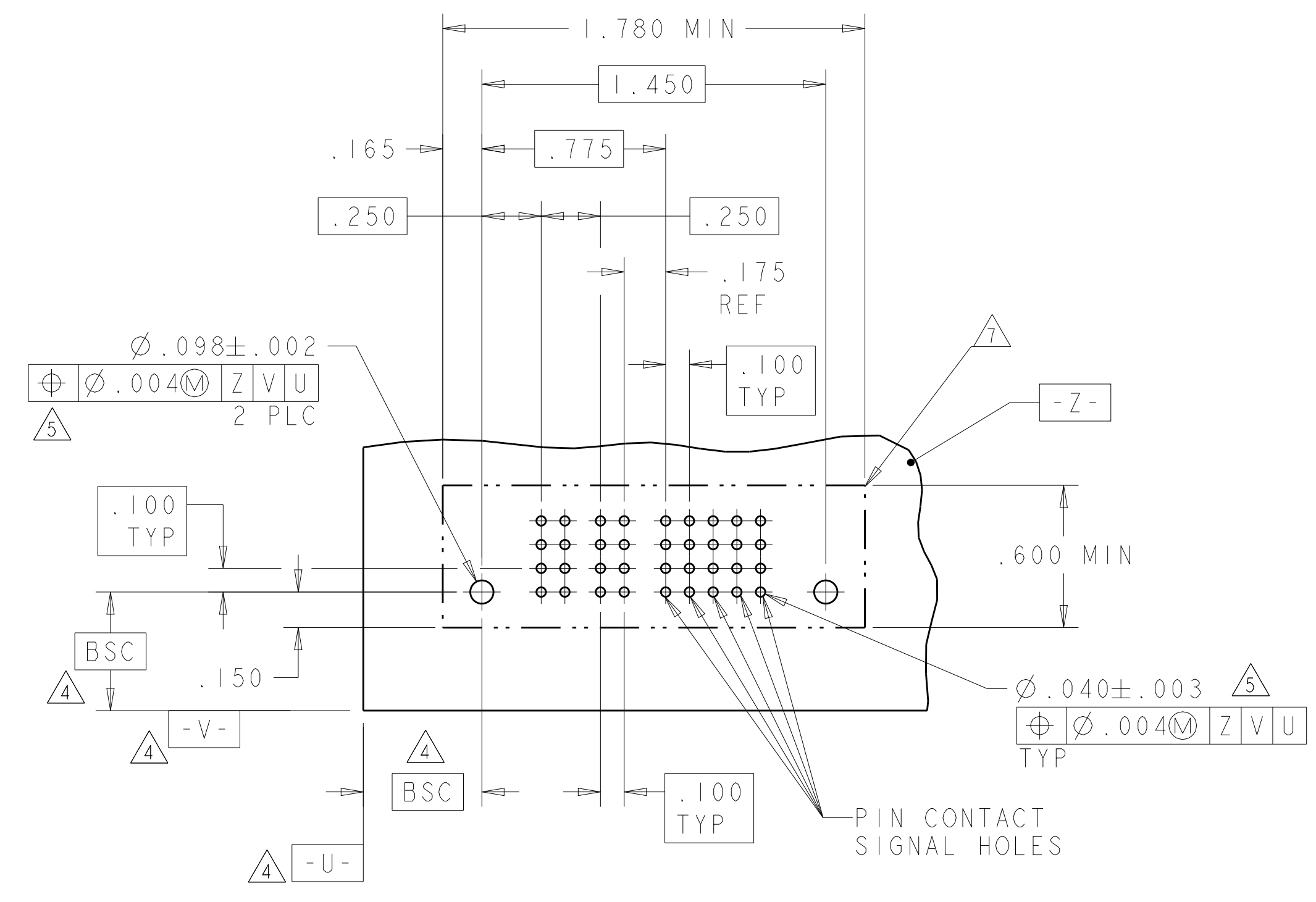

RECOMMENDED PCB LAYOUT 6600313-2
 SCALE 2:1

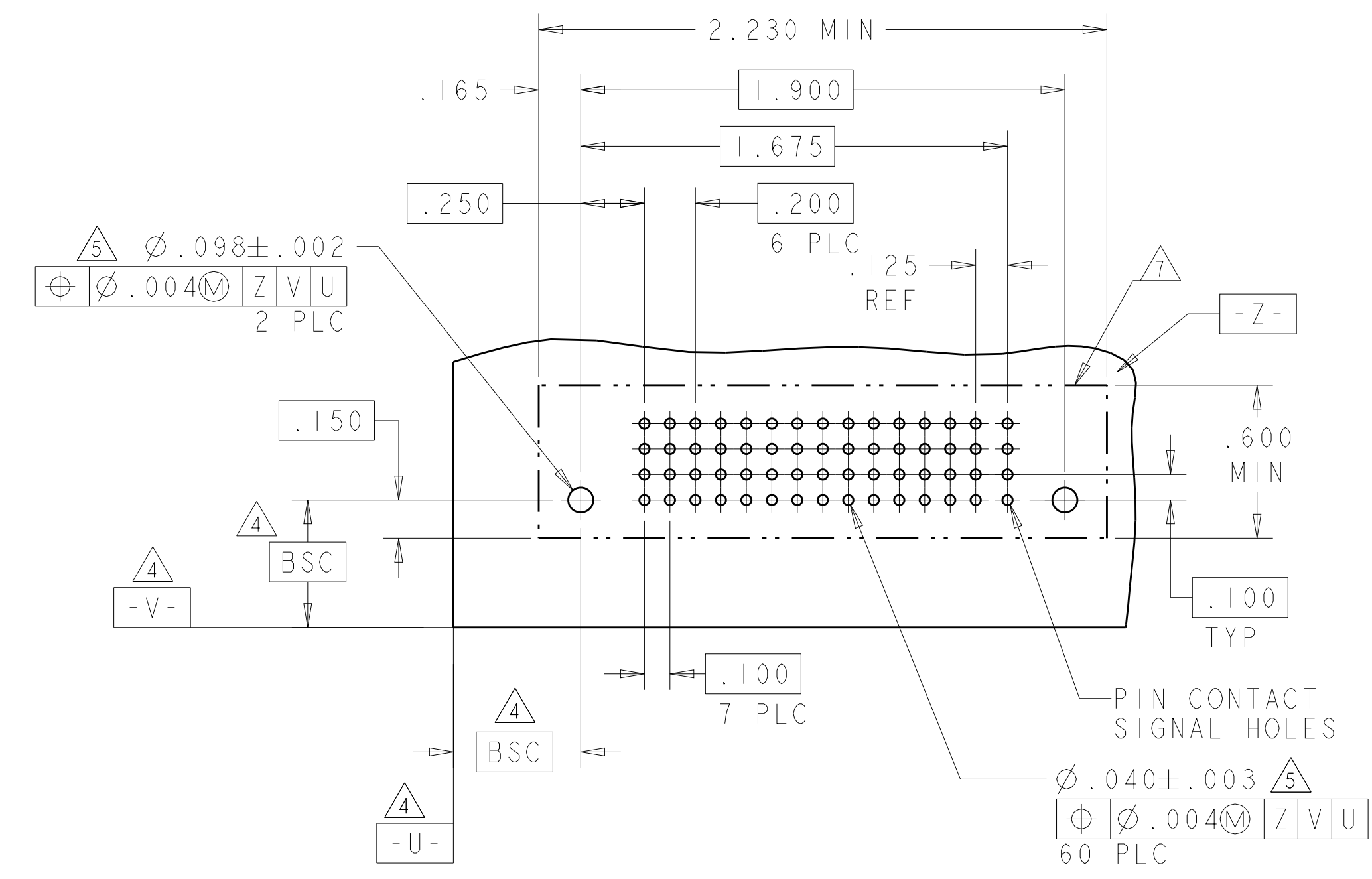

PART NUMBER	ROWS	POWER						SIGNAL			HD
		P1	P2	P3	P4	P5	P6	1	2	3	
6600313-3	D	VM	VM	VM	VM	VM	VM	EV	EV	EV	HD
	C							EV	EV	EV	
	B							EV	EV	EV	
	A							EV	EV	EV	
6P+12S		HD							HD		

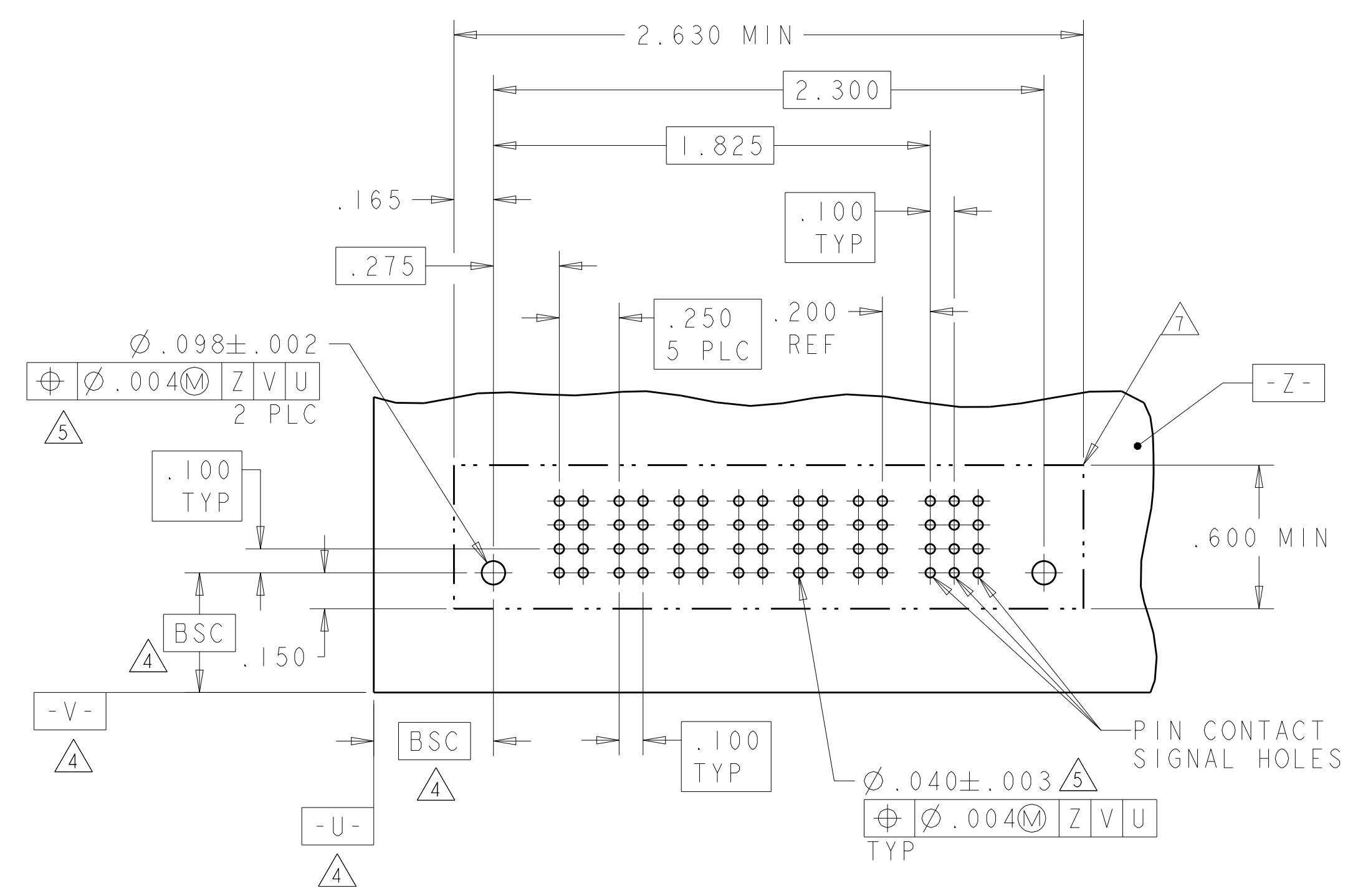

RECOMMENDED PCB LAYOUT 6600313-3
 SCALE 2:1

MATING SEQUENCE	DESCRIPTION	IDENTIFIER
-	RETENTION CLIP	HD
MLBF	SIGNAL CONTACT, .165 TAIL LENGTH, PRESS FIT.	ES
STANDARD	SIGNAL CONTACT, .165 TAIL LENGTH, PRESS FIT.	EV
-	POWER CONTACT, .165 TAIL LENGTH, PRESS FIT.	VM

DIMENSIONS: INCH 		TOLERANCES UNLESS OTHERWISE SPECIFIED: 0 PLC ± 1 PLC ±0.1 2 PLC ± 3 PLC ±0.005 4 PLC ± ANGLES ±		DWN J. McCLINTON 06OCT05 CHK D. TROUT 06OCT05 APVD P. MLYNE 06OCT05 PRODUCT SPEC 108-1973 APPLICATION SPEC 114-13038 WEIGHT CUSTOMER DRAWING		Tyco Electronics Corporation Shanghai, P.R. China. 200233 NAME VERTICAL HEADER ASSEMBLY, W/GUIDES PRESS FIT, TYPE PS MULTI-BEAM XL SIZE CAGE CODE DRAWING NO A100779C=6600313 SCALE 3:1 SHEET 2 OF 7 REV G1	
-------------------------	--	-------------------------------------------------------------------------------------------------------------------	--	----------------------------------------------------------------------------------------------------------------------------------------------------------------	--	-------------------------------------------------------------------------------------------------------------------------------------------------------------------------------------------------------------------------------	--

LOC	DIST	REV	DATE	BY	APPD
ES	00				

PART NUMBER	ROWS	POWER								S		
		P1	P2	P3	P4	P5	P6	P7	P8	P9	1	2
6600313-9	D										EV	EV
	C	VM	VM	VM	VM	VM	VM	VM	VM		EV	EV
	B										EV	EV
	A										EV	EV
9HDP+8S		HD								HD		

PART NUMBER	ROWS	POWER								S		
		P1	P2	P3	P4	P5	P6	P7	P8	P9	1	2
1-6600313-1	D										EV	EV
	C	VM	VM	VM	VM	VM	VM	VM	VM		EV	EV
	B										EV	EV
	A										EV	EV
9ACP+8S		HD								HD		

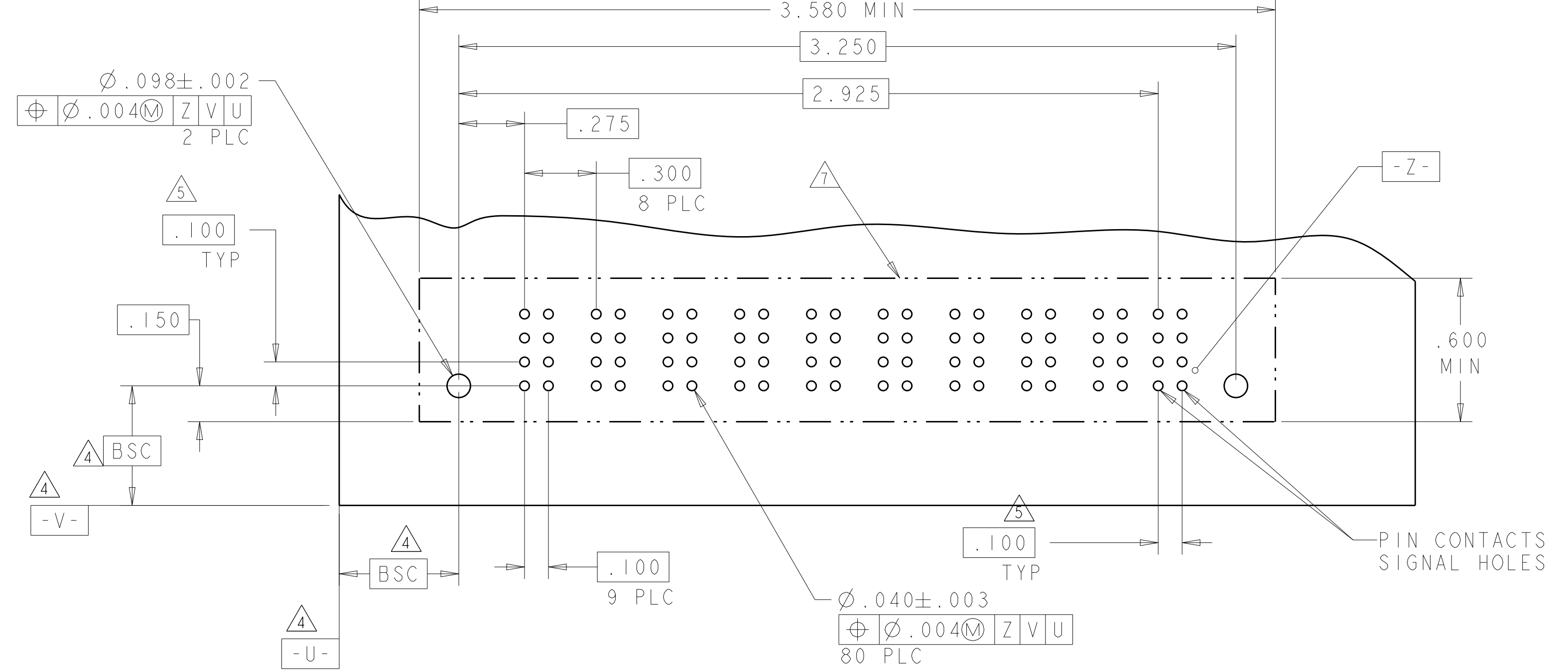
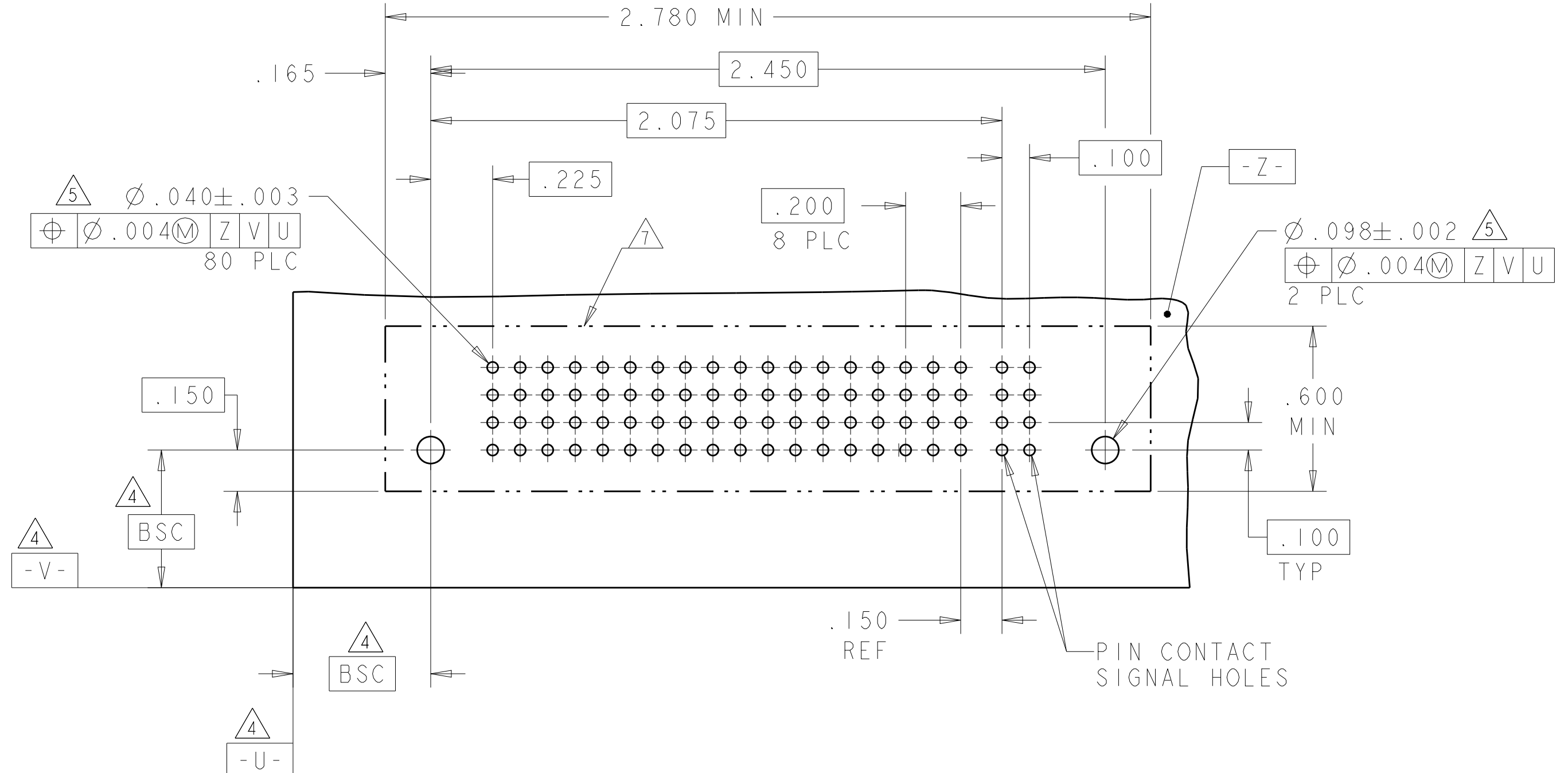

PART NUMBER	ROWS	POWER				S	
		P1	P2	P3	P4	1	2
1-6600313-0	D					EV	EV
	C	VM	VM	VM	VM	EV	EV
	B					EV	EV
	A					EV	ES
4P + 8S		HD				HD	

PART NUMBER	ROWS	S	
		1	2
1-6600313-2	D	EV	EV
	C	EV	EV
	B	EV	EV
	A	EV	EV
8S		HD	HD

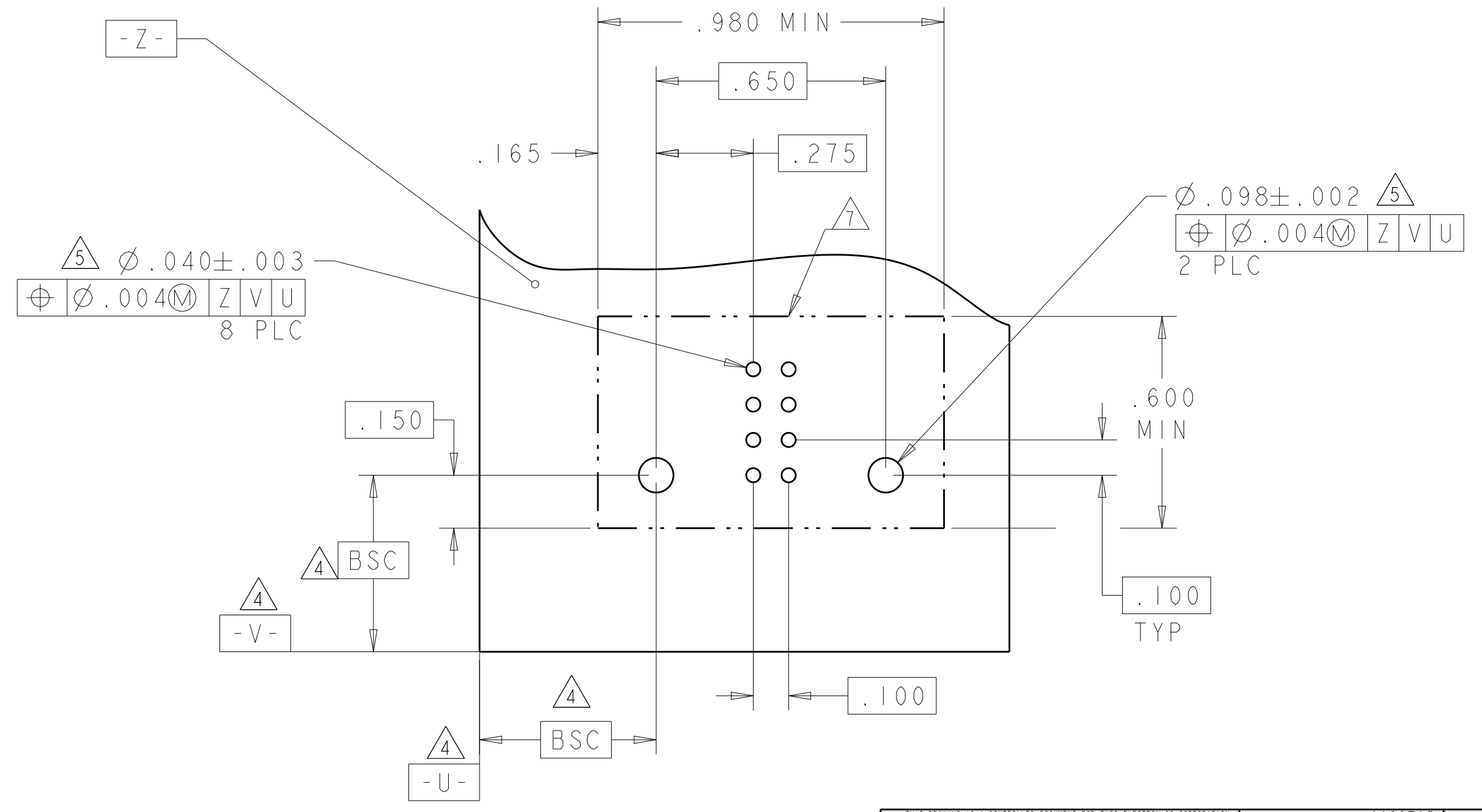
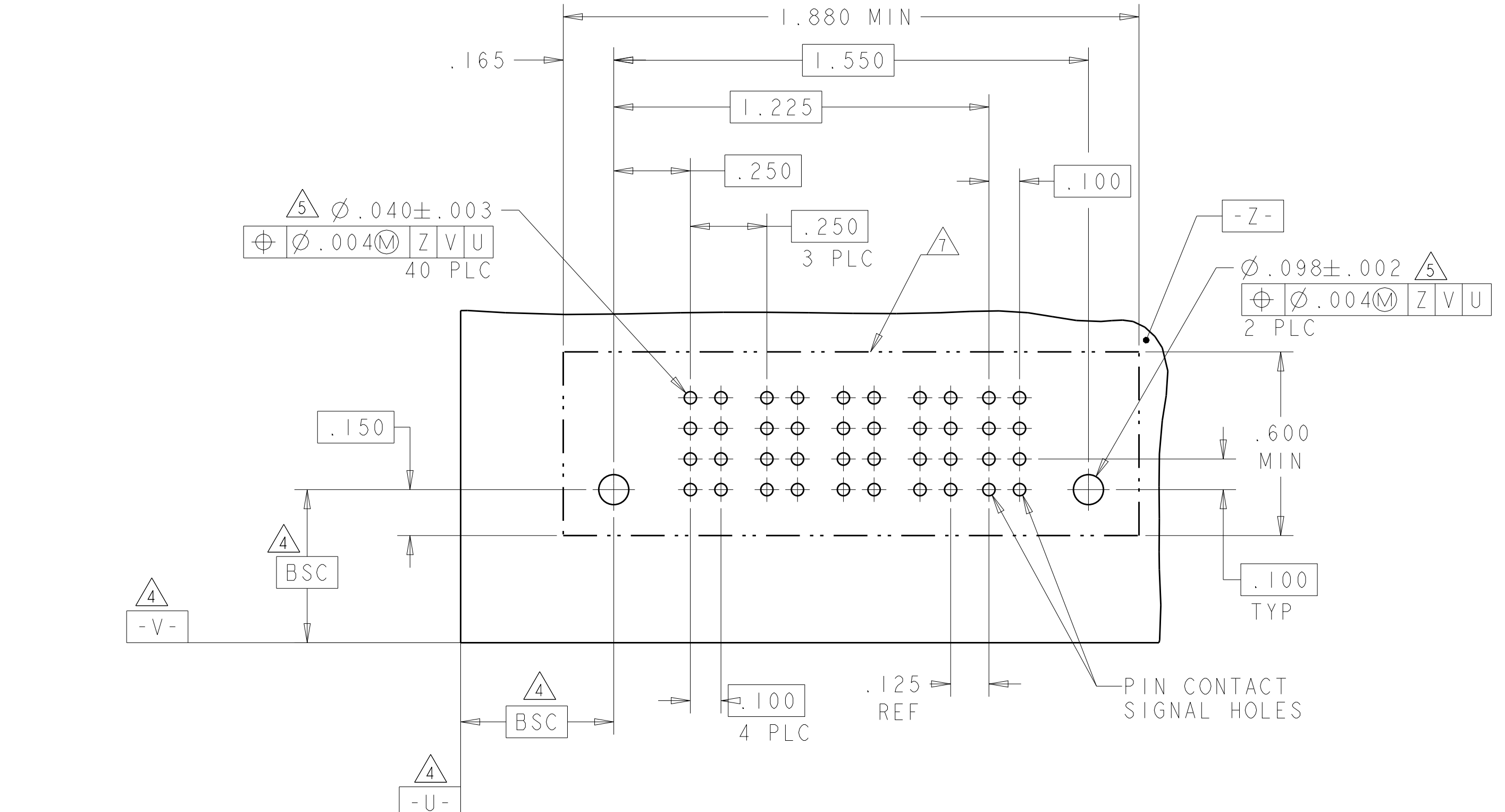

DIMENSIONS: INCH 		TOLERANCES UNLESS OTHERWISE SPECIFIED: 0 PLC ±.1 1 PLC ±.1 2 PLC ±.1 3 PLC ±.005 4 PLC ±.1 ANGLES ±.1		DWN J. McCLINTON 06OCT05 CHK D. TROUT 06OCT05 APVD B. MHYNE 06OCT05 PRODUCT SPEC 108-1973 APPLICATION SPEC 114-13038 WEIGHT CUSTOMER DRAWING		Tyco Electronics Corporation Shanghai, P.R. China. 200233 NAME VERTICAL HEADER ASSEMBLY, W/GUIDES PRESS FIT, TYPE PS MULTI-BEAM XL SIZE CAGE CODE DRAWING NO. A1100779C=6600313 RESTRICTED TO	
MATERIAL FINISH		SCALE 3:1 SHEET 3 OF 7 REV G1		DATE		BY	

LOC	DIST	REV	DATE	BY	APPV
ES	00				
REVISIONS			DESCRIPTION	DATE	BY
			SEE SHEET 1		

PART NUMBER	ROWS	POWER				S				
		P1	P2	P3	P4	1	2	3	4	5
I-6600313-6	D	VM	VM	VM	VM	EV	EV	EV	EV	EV
	C					EV	EV	EV	EV	EV
	B					EV	EV	EV	EV	EV
	A					EV	EV	EV	EV	EV
4P + 20S										

PART NUMBER	ROWS	POWER								SIGNAL						
		P1	P2	P3	P4	P5	P6	P7	P8	P9	1	2	3	4	5	6
I-6600313-7	D	VM	VM	VM	VM	VM	VM	VM	VM	VM	EV	ES	EV	EV	EV	ES
	C										EV	EV	EV	EV	ES	ES
	B										EV	EV	EV	EV	ES	ES
	A										EV	EV	EV	EV	ES	EV
3ACP + 6P + 24S																

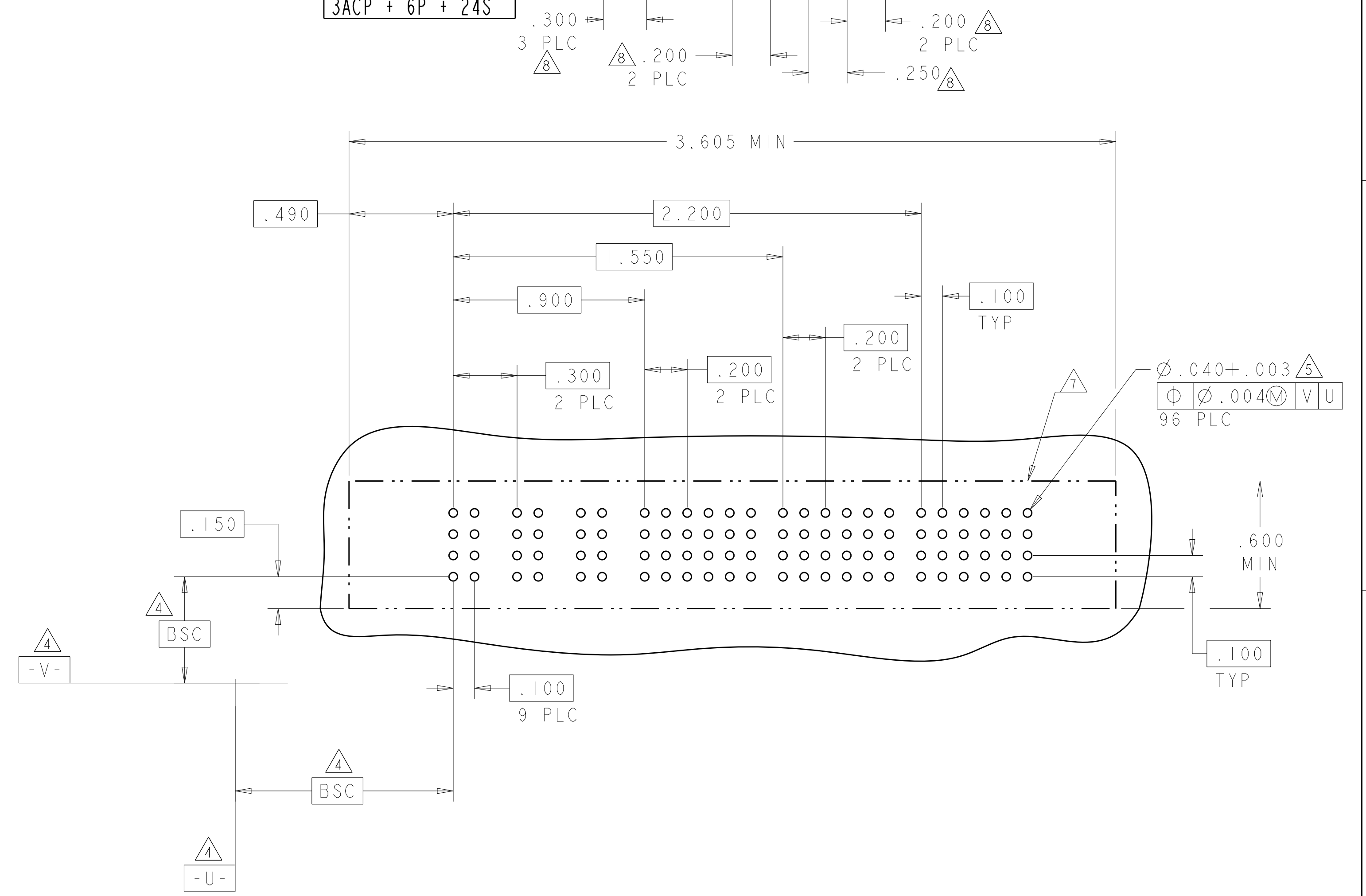
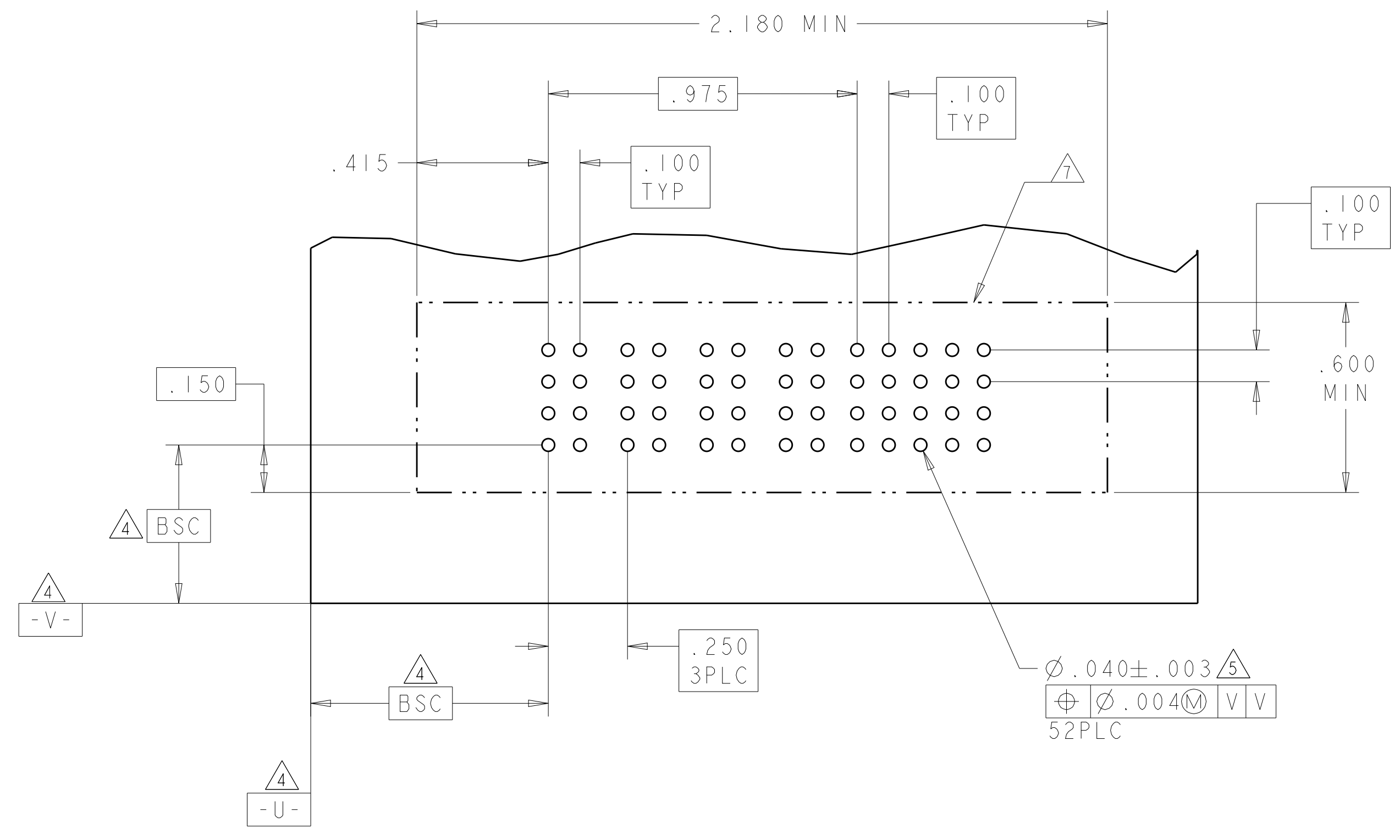

<small>THIS DRAWING IS UNPUBLISHED. RELEASED FOR PUBLICATION. IT IS THE POLICY OF TYCO ELECTRONICS CORPORATION TO CONTINUE TO IMPROVE ITS PRODUCTS. THE USER IS ADVISED TO CONTACT TYCO ELECTRONICS CORPORATION FOR THE LATEST REVISION.</small>		DWN: J. McCLINTON 06OCT05 CHK: D. TROUT 06OCT05 APVD: B. WHYNE 06OCT05	Tyco Electronics Corporation Shanghai, P.R. China. 200233
DIMENSIONS: INCH 	TOLERANCES UNLESS OTHERWISE SPECIFIED: 0 PLC ±. 1 PLC ±0.1 2 PLC ±. 3 PLC ±0.005 4 PLC ±. ANGLES ±.	NAME: VERTICAL HEADER ASSEMBLY, W/GUIDES PRESS FIT, TYPE PS MULTI-BEAM XL PRODUCT SPEC: 108-1973 APPLICATION SPEC: 114-13038 WEIGHT:	SIZE: A CAGE CODE: 00779 DRAWING NO: 6600313 RESTRICTED TO:
MATERIAL:	FINISH:	CUSTOMER DRAWING	SCALE: 3:1 SHEET 5 OF 7 REV: G1

LOC		DIST		REVISIONS			
ES	00	P	LTH	DESCRIPTION	DATE	DMN	APVD
		-		SEE SHEET 1	-	-	-

PART NUMBER	ROWS	POWER		SIGNAL																								
		P1	P2	1	2	3	4	5	6	7	8	9	10	11	12	13	14	15	16	17	18	19	20	21	22	23		
1-6600313-8	D	VM	VM	EV	EV	EV	EV	EV	EV	EV	EV	EV	EV	EV	EV	EV	EV	EV	EV	EV	EV	EV	EV	EV	EV	EV	EV	
	C			EV	EV	EV	EV	EV	EV	EV	EV	EV	EV	EV	EV	EV	EV	EV	EV	EV	EV	EV	EV	EV	EV	EV	EV	EV
	B			EV	EV	EV	EV	EV	EV	EV	EV	EV	EV	EV	EV	EV	EV	EV	EV	EV	EV	EV	EV	EV	EV	EV	EV	EV
	A			EV	EV	EV	EV	EV	EV	EV	EV	EV	EV	EV	EV	EV	EV	EV	EV	EV	EV	EV	EV	EV	EV	EV	EV	EV
2P + 92S																												

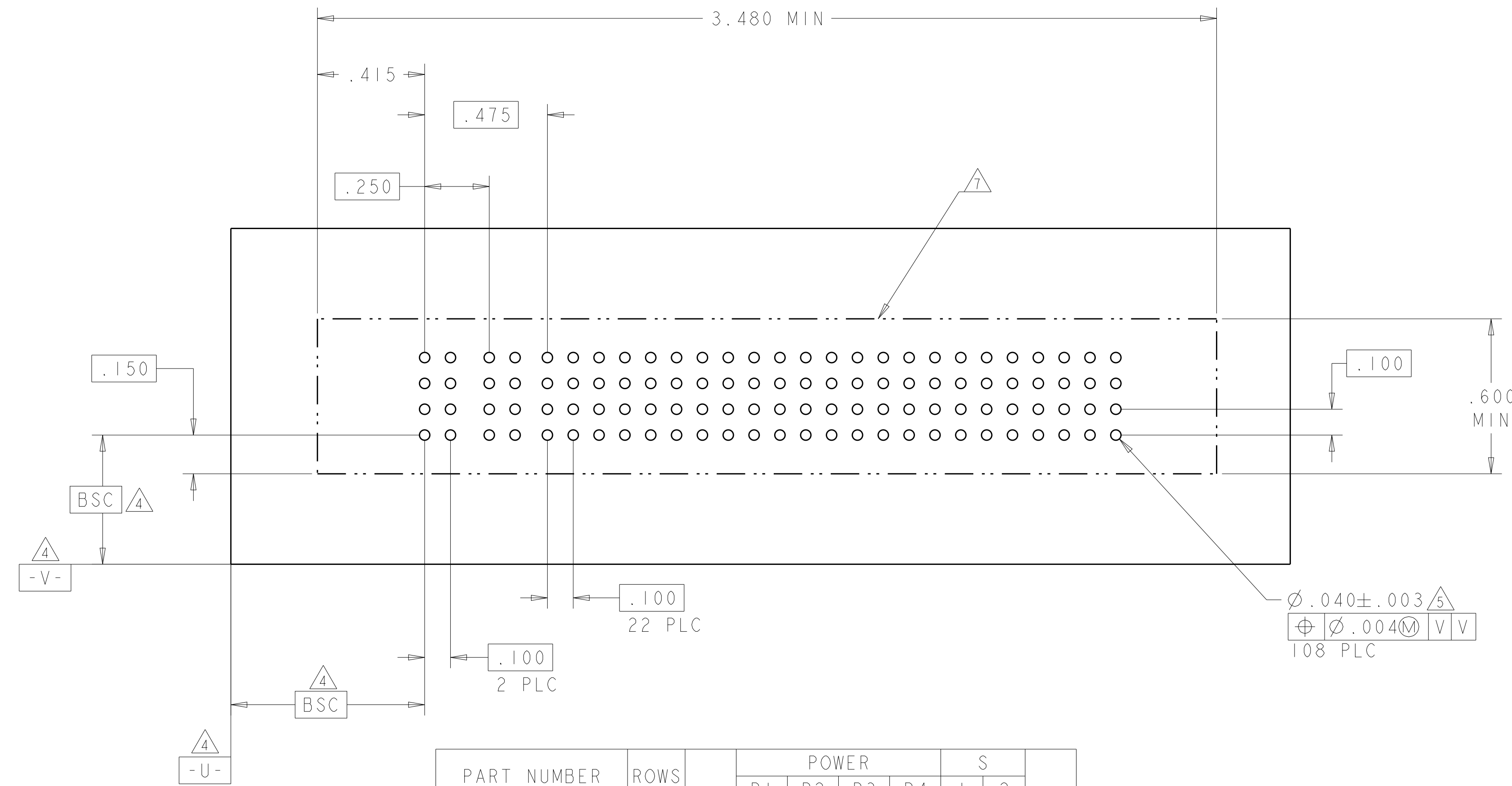

PART NUMBER	ROWS	POWER				S	
		P1	P2	P3	P4	1	2
1-6600313-9	D	VM	VM	VM	VM	EV	EV
	C					EV	EV
	B					EV	EV
	A					EV	EV
4P + 8S							

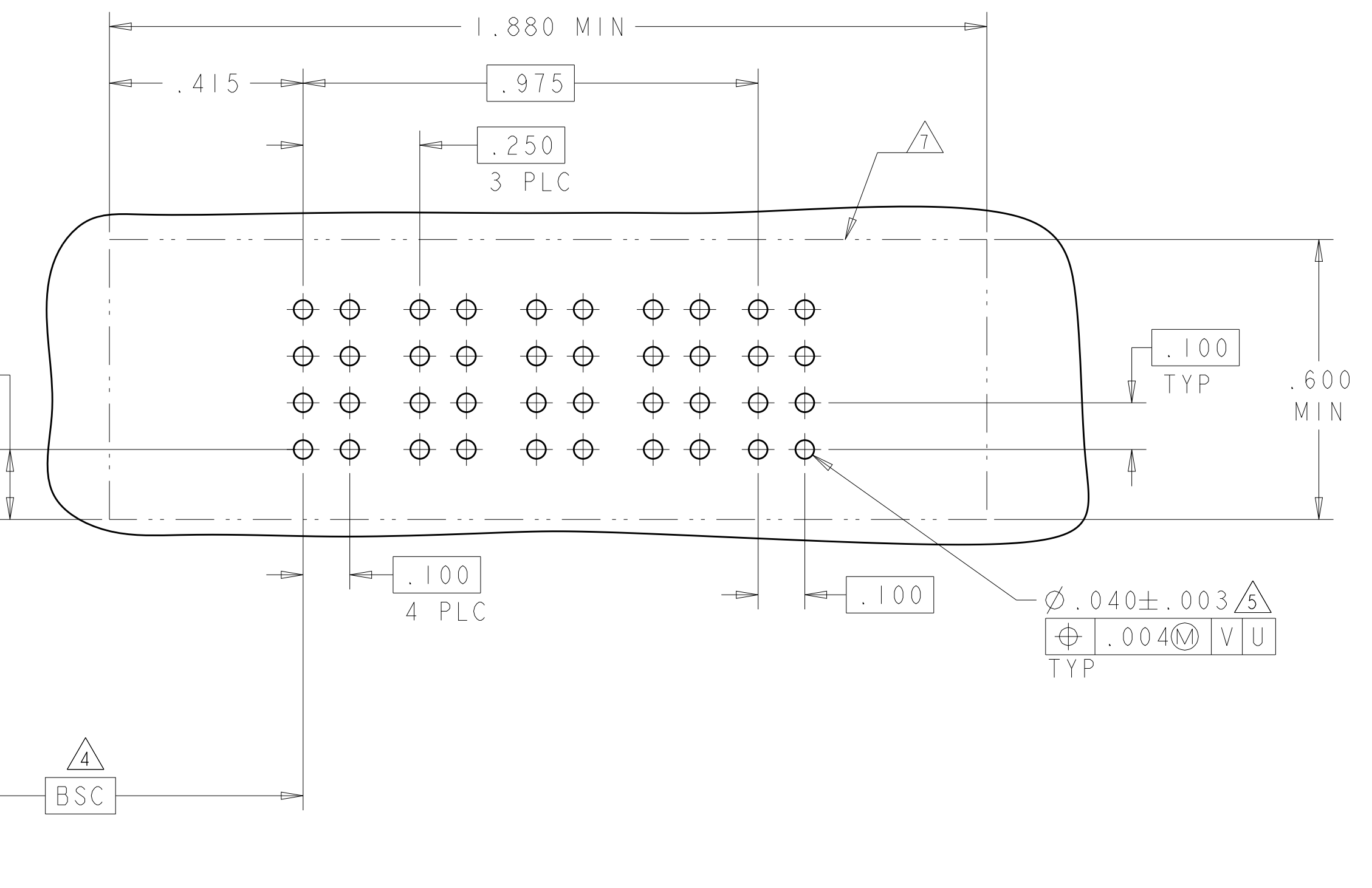

PART NUMBER	ROWS	S			
		1	2	3	4
2-6600313-0	D	ES	EV	ES	ES
	C	ES	EV	ES	ES
	B	ES	EV	ES	ES
	A	ES	EV	ES	ES
16S					

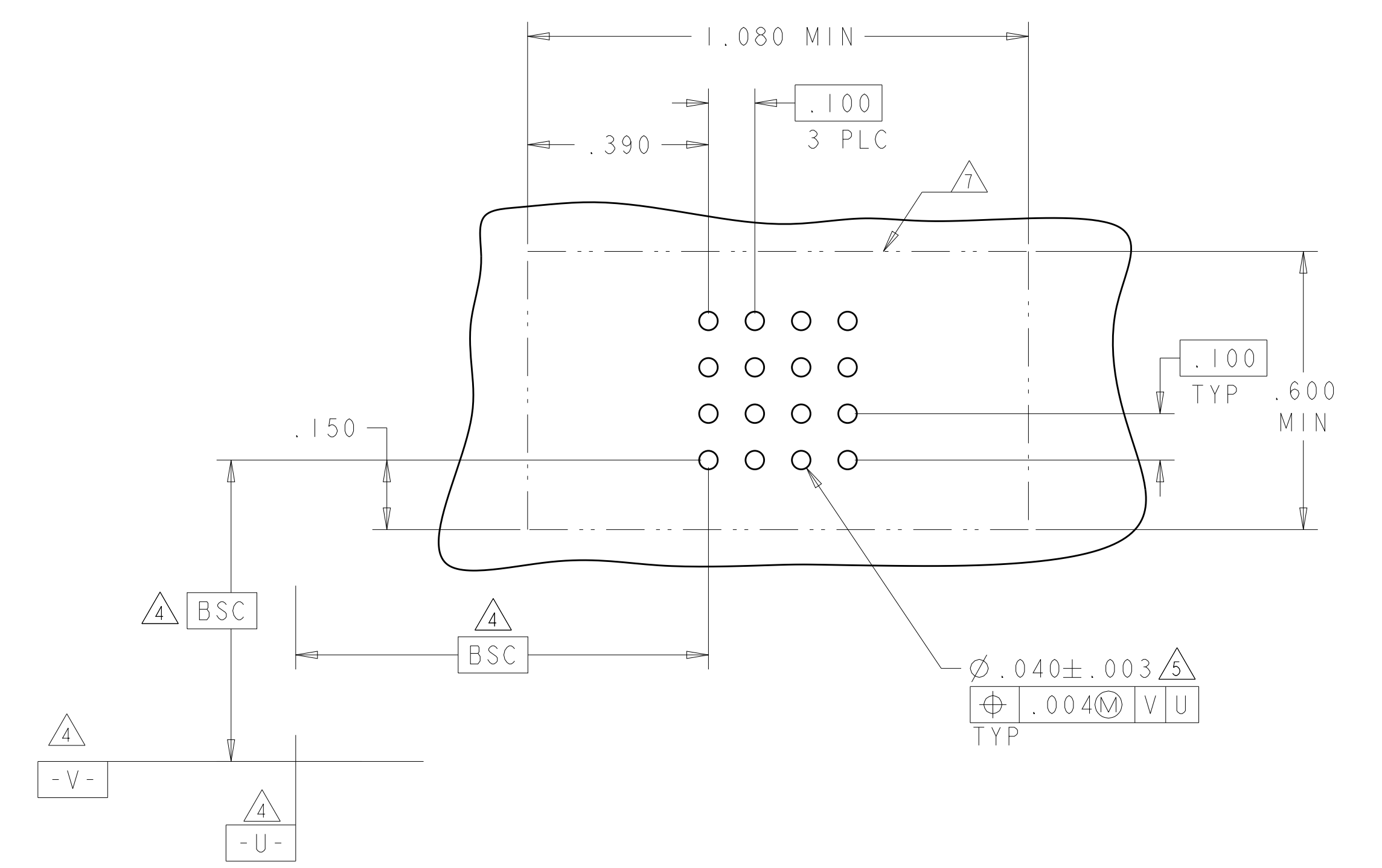

<small>THIS DRAWING IS UNPUBLISHED. RELEASED FOR PUBLICATION BY TYCO ELECTRONICS CORPORATION. ALL RIGHTS RESERVED.</small>		DMN J. McCLINTON 06OCT05 CHK D. TROUT 06OCT05 APVD B. WHYNE 06OCT05	Tyco Electronics Corporation Shanghai, P.R. China. 200233
DIMENSIONS: INCH 	TOLERANCES UNLESS OTHERWISE SPECIFIED: 0 PLC ±.1 1 PLC ±.1 2 PLC ±.05 3 PLC ±.005 4 PLC ±.005 ANGLES ±.1	NAME VERTICAL HEADER ASSEMBLY, W/GUIDES PRESS FIT, TYPE PS MULTI-BEAM XL PRODUCT SPEC 108-1973 APPLICATION SPEC 114-13038	SIZE CAGE CODE DRAWING NO. RESTRICTED TO A100779C=6600313 CUSTOMER DRAWING SCALE 3:1 SHEET 6 OF 7 REV G1

LOC	DIST	REVISIONS			
P	LTN	DESCRIPTION	DATE	DWN	APVD
ES	00	- SEE SHEET 1	-	-	-

PART NUMBER	ROWS	POWER							SIGNAL					
		P1	P2	P3	P4	P5	P6	P7	1	2	3	4	5	6
6600313-6	D C B A	VM	VM	VM	VM	VM	VM	VM	EV	ES	EV	EV	EV	ES
		VM	VM	VM	VM	VM	VM	VM	EV	ES	EV	EV	EV	ES
		VM	VM	VM	VM	VM	VM	VM	EV	ES	EV	EV	EV	ES

3ACP + 4P + 24S

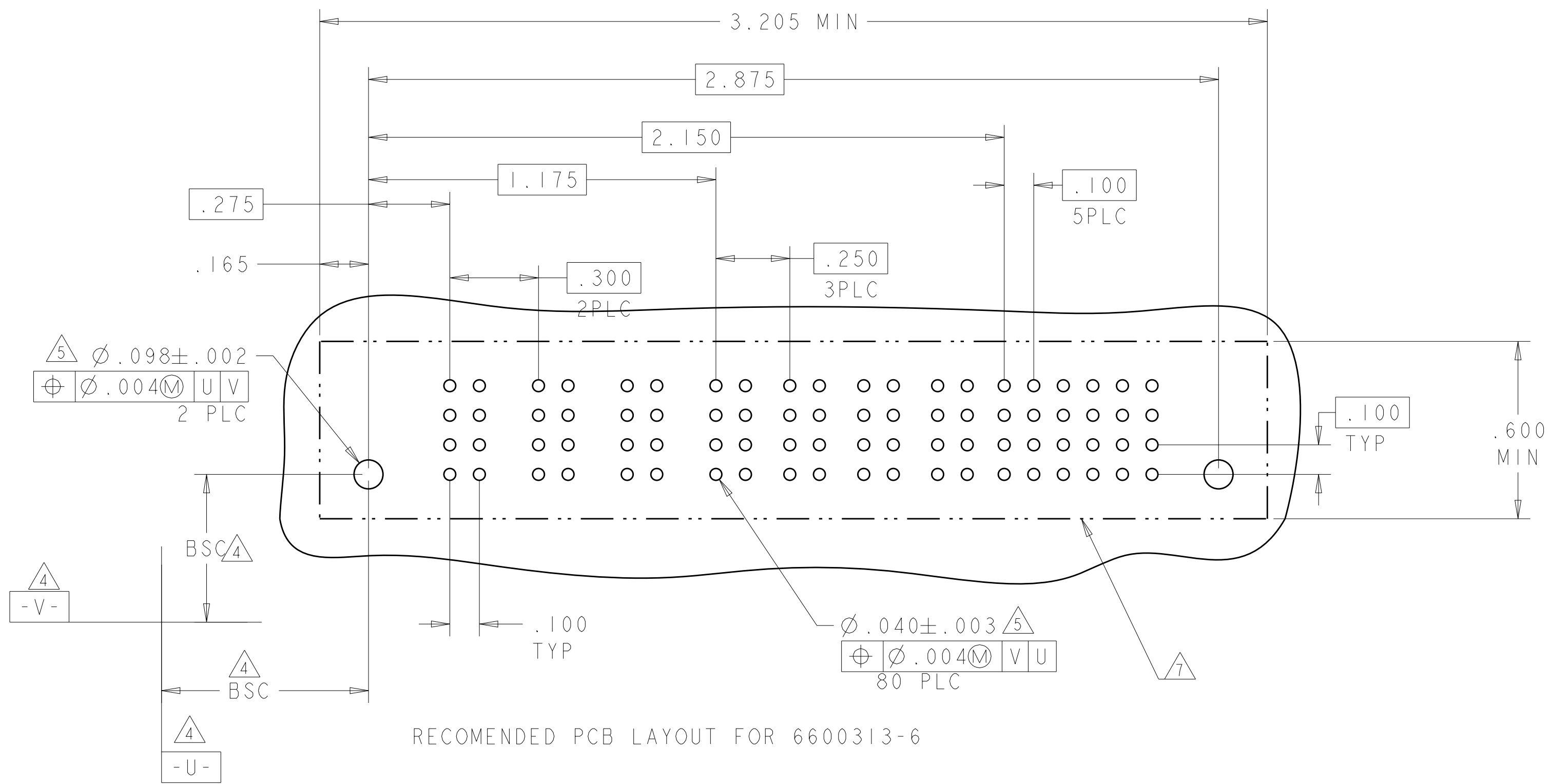
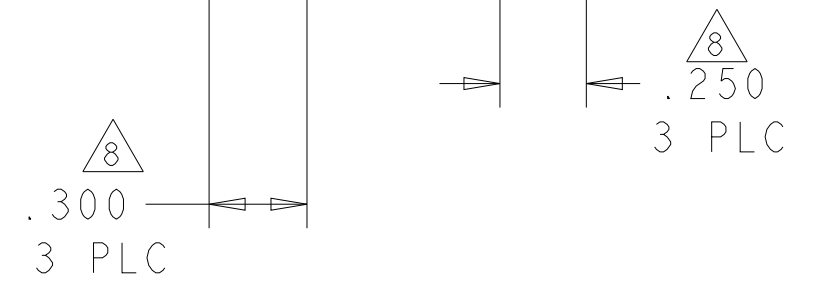

<small>THIS DRAWING IS UNPUBLISHED. RELEASED FOR PUBLICATION. IT IS THE PROPERTY OF TYCO ELECTRONICS CORPORATION AND IS TO BE USED ONLY FOR THE PURPOSES AND IN THE MANNER SPECIFIED BY THE ORIGINAL DRAWING. IT IS THE RESPONSIBILITY OF THE USER TO CONTACT TYCO ELECTRONICS CORPORATION FOR THE LATEST REVISION.</small>		DWN J. McCLINTON 06OCT05 CHK D. TROUT 06OCT05 APVD B. WHYNE 06OCT05	Tyco Electronics Corporation Shanghai, P.R. China. 200233
DIMENSIONS: INCH 		TOLERANCES UNLESS OTHERWISE SPECIFIED: 0 PLC ±. 1 PLC ±0.1 2 PLC ±. 3 PLC ±0.005 4 PLC ±. ANGLE ±. FINISH	NAME VERTICAL HEADER ASSEMBLY, W/GUIDES PRESS FIT, TYPE PS MULTI-BEAM XL
MATERIAL		WEIGHT 114-13038	SIZE CAGE CODE DRAWING NO A 100779 C=6600313
CUSTOMER DRAWING		SCALE 3:1	SHEET 7 OF 7 REV G1