

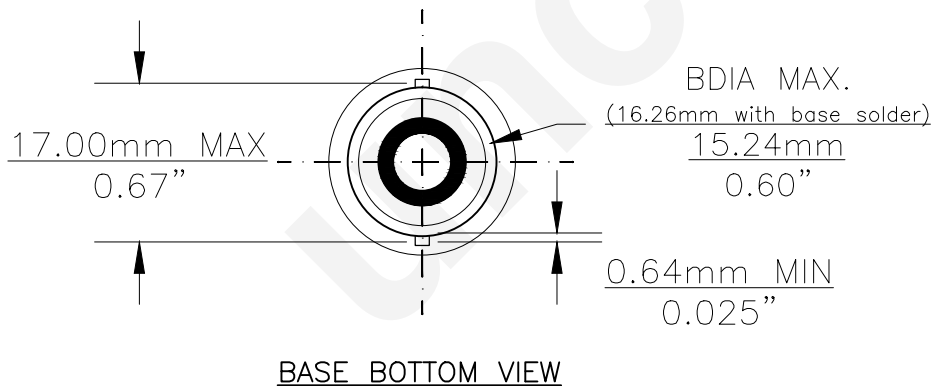

| PART NO. | BASE TYPE | DESIGN VOLTS | DESIGN AMPS | MSCD | FILAMENT TYPE | AVERAGE LIFE HOURS | REVISIONS | | | |
|----------|----------------------|--------------|-------------|--------|---------------|--------------------|-----------|-----------------------------------|------------|----------|
| | | | | | | | REV # | DESCRIPTION | DATE | APPROVED |
| 97 | S.C. BAYONET (BA15s) | 13.5V | 0.69 ±8% | 4 ±15% | C-6 | 5000 | 1 | ISSUED | 02/01/2001 | E.S. |
| | | | | | | | 2 | TOLERANCE, AMP, MSCD, LCL | 09/21/2009 | D.C. |
| | | | | | | | 3 | UPDATED FILAMENT FROM C-2V TO C-6 | 06/03/15 | R.M. |

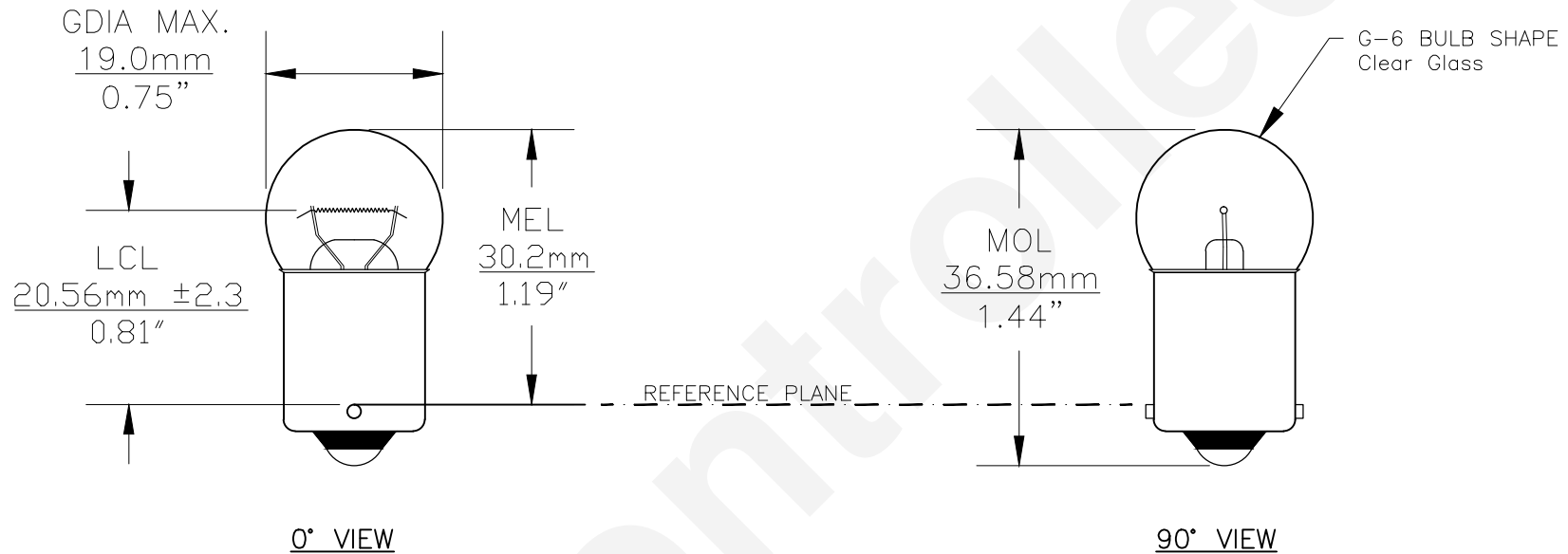

Note: Made according to SAE specifications

| | | | | | |
|---|-----------------|-------------------------|----------------------|------------------------|-------|
| UNLESS OTHERWISE SPECIFIED: DIMENSIONS ARE IN INCHES TOLERANCES | | CEC INDUSTRIES LTD | | | |
| DECIMALS .XX ± .05 | | 599 BOND STREET | | LINCOLNSHIRE, IL 60069 | |
| ANGULAR .XXX ± .010 | | TITLE LIGHT BULB NO. 97 | | | |
| FRACTIONAL ±1/64 | | SIZE A | FSCM NO. | DWG NO. 97 | REV 3 |
| DRAWN ELIZABETH SONANES | DATE 02/01/2001 | SCALE | PLOT SCALE | SHEET 1 OF 1 | |
| MATERIAL | | FILE 97.pdf | DRAWING NOT TO SCALE | | |