

Am29C117

16-Bit CMOS Microprocessor



NOV 21 1987

Am29C117

DISTINCTIVE CHARACTERISTICS

- High-Speed Microprocessor
 - Am29C117-2 supports up to 65 ns microcycle times.
- Very Low Power
- Optimized for High-Performance Controllers
 - The architecture is optimized for controllers providing an excellent solution for applications requiring bit-manipulation power.
- Flow-Through Architecture
 - Separate input and output ports avoid bus turnaround for higher throughput.
- Instruction Set is identical to the Am29C116
 - The Am29C117 has an identical architecture and instruction set with the exception of the two-port I/O structure and the additional Two-Address Immediate Instruction.
- 16-Bit Barrel Shifter
- 32 Working Registers
- 68-Lead Pin Grid Array and Plastic Leaded Chip Carrier Packages.

GENERAL DESCRIPTION

The Am29C117 is a microprogrammable 16-bit CMOS microprocessor whose architecture and instruction set are identical to the Am29C116's except for the I/O bus structure. Since the device has separate input and output ports, designers can avoid quick bus turnaround requirements.

The architecture and instruction set are not only optimized for high-performance peripheral controllers, but also suit-

able for microprogrammed processor applications when combined with the Am29C517A 16 x 16 Multiplier.

The instruction set contains unique functions besides ordinary logic and arithmetic functions: bit manipulation instructions (set, reset and test), rotate merge/compare instructions, prioritize instruction, and CRC instruction.

BLOCK DIAGRAM

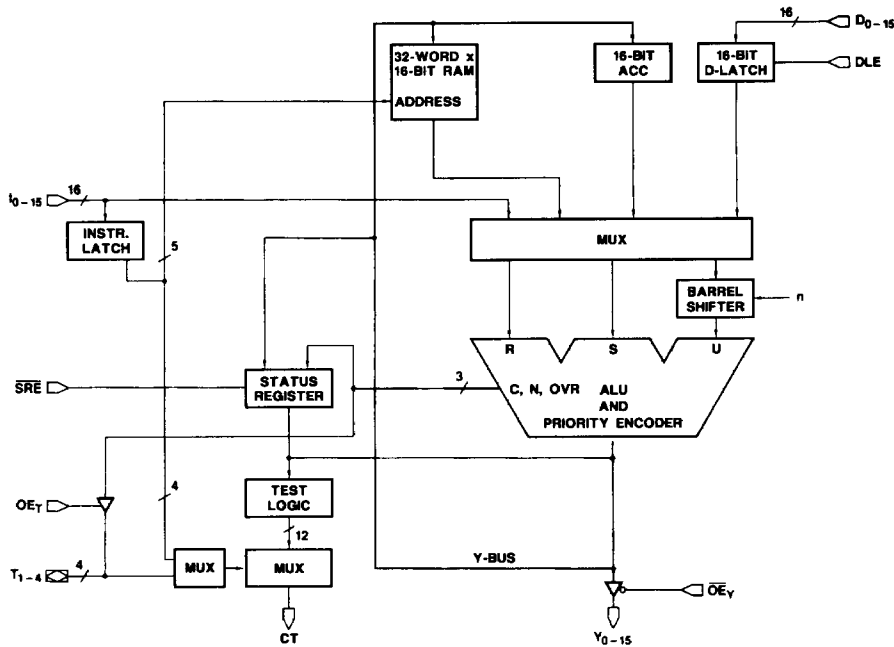

BD001973

Advanced Micro Devices

Publication # Rev. Amendment
07698 B /0
Issue Date: September 1988

RELATED AMD PRODUCTS

Part No.	Description
Am29027	Arithmetic Accelerator
Am2910A	Microprogram Controller
Am29C10A	CMOS 12-Bit Sequencer
Am29C111	CMOS 16-Bit Microsequencer
Am29114	8-Level Real-Time Interrupt Controller
Am29116	16-Bit Bipolar Microprocessor
Am29C116/-1/-2	16-Bit CMOS Microprocessors
Am29117	2-Port 16-Bit Microprocessor
Am29118	8-Bit Am29C116 I/O Support
Am29130	16-Bit Barrel Shifter
Am2914	Vectored Priority Interrupt Controller
Am29PL141	64 x 32 Field-Programmable Controller
Am29CPL141	CMOS 64 Word Field-Programmable Controller
Am29LPL141	Low-Power Version of Am29PL141
Am29PL142	128 x 32 Field-Programmable Controller
Am29C323	CMOS 32-Bit Parallel Multiplier
Am29325	32-Bit Floating-Point Processor
Am29C325	CMOS 32-Bit Floating-Point Processor
Am29C327	CMOS Double-Precision Floating-Point Processor
Am29331	16-Bit Microprogram Sequencer
Am29C331	CMOS 16-Bit Microsequencer
Am29334	Four-Port Dual-Access Register File
Am29C334	CMOS Four-Port Dual-Access Register File
Am29337	16-Bit Bounds Checker
Am29C516A	CMOS 16 x 16 Multiplier
Am29C517A	CMOS 2-Port 16 x 16 Multiplier
Am29540	Programmable FFT Address Sequencer

CONNECTION DIAGRAMS

PGA (Pins Facing Up)

	A	B	C	D	E	F	G	H	J	K	L
1	Y ₁	NC	D ₅	D ₃	D ₁	D ₀	I ₁₄	I ₁₂	I ₁₀		
2	Y ₃	Y ₂	Y ₀	D ₆	D ₄	D ₂	I ₁₅	I ₁₃	I ₁₁	I ₉	I ₈
3	Y ₄	D ₇								I ₇	I ₆
4	Y ₆	Y ₅								I ₅	GND
5	OE _Y	GND								I ₄	V _{CC}
6	NC	Y ₇								I ₃	I ₂
7	V _{CC0}	Y ₈								I ₀	I ₁
8	Y ₉	Y ₁₀								IEN	CP
9	DLE	GND								CT	SRE
10	Y ₁₁	Y ₁₂	Y ₁₃	Y ₁₅	D ₉	D ₁₂	T ₂	D ₁₃	D ₁₅	T ₄	OE _T
11		D ₈	Y ₁₄	NC	D ₁₀	D ₁₁	T ₁	GND	D ₁₄	T ₃	

078888-001A

CD011680

LCC* Top View

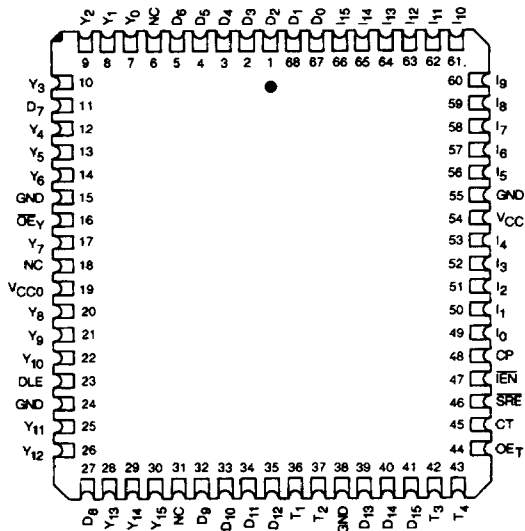

CD009862

*Also available in a 68-pin PLCC; pinout identical to LCC.

V_{CC} are power connections for the logic.

V_{CC0} are power connections for the output drivers.

Note: Pin 1 is marked for orientation.

PGA PIN DESIGNATIONS

(Sorted by Pin Number)

PIN NO.	PIN NAME	PIN NO.	PIN NAME	PIN NO.	PIN NAME	PIN NO.	PIN NAME
A-2	Y ₃	B-9	GND	F-10	D ₁₂	K-4	I ₅
A-3	Y ₄	B-10	Y ₁₂	F-11	D ₁₁	K-5	I ₄
A-4	Y ₆	B-11	D ₈	G-1	D ₀	K-6	I ₃
A-5	OE _Y	C-1	NC	G-2	I ₁₅	K-7	I ₀
A-6	NC	C-2	Y ₀	G-10	T ₂	K-8	IEN
A-7	VCC ₀	C-10	Y ₁₃	G-11	T ₁	K-9	CT
A-8	Y ₉	C-11	Y ₁₄	H-1	I ₁₄	K-10	T ₄
A-9	DLE	D-1	D ₅	H-2	I ₁₃	K-11	T ₃
A-10	Y ₁₁	D-2	D ₆	H-10	D ₁₃	L-2	I ₈
B-1	Y ₁	D-10	Y ₁₅	H-11	GND	L-3	I ₆
B-2	Y ₂	D-11	NC	J-1	I ₁₂	L-4	GND
B-3	D ₇	E-1	D ₃	J-2	I ₁₁	L-5	VCC
B-4	Y ₅	E-2	D ₄	J-10	D ₁₅	L-6	I ₂
B-5	GND	E-10	D ₉	J-11	D ₁₄	L-7	I ₁
B-6	Y ₇	E-11	D ₁₀	K-1	I ₁₀	L-8	CP
B-7	Y ₈	F-1	D ₁	K-2	I ₉	L-9	SRE
B-8	Y ₁₀	F-2	D ₂	K-3	I ₇	L-10	OE _T

(Sorted by Pin Name)

PIN NO.	PIN NAME	PIN NO.	PIN NAME	PIN NO.	PIN NAME	PIN NO.	PIN NAME
L-8	CP	J-10	D ₁₅	J-2	I ₁₁	A-7	VCC ₀
K-9	CT	A-9	DLE	J-1	I ₁₂	C-2	Y ₀
G-1	D ₀	B-5	GND	H-2	I ₁₃	B-1	Y ₁
F-1	D ₁	L-4	GND	H-1	I ₁₄	B-2	Y ₂
F-2	D ₂	B-9	GND	G-2	I ₁₅	A-2	Y ₃
E-1	D ₃	H-11	GND	K-8	IEN	A-3	Y ₄
E-2	D ₄	K-7	I ₀	C-1	NC	B-4	Y ₅
D-1	D ₅	L-7	I ₁	D-11	NC	A-4	Y ₆
D-2	D ₆	L-6	I ₂	A-6	NC	B-6	Y ₇
B-3	D ₇	K-6	I ₃	L-10	OE _T	B-7	Y ₈
B-11	D ₈	K-5	I ₄	A-5	OE _Y	A-8	Y ₉
E-10	D ₉	K-4	I ₅	L-9	SRE	B-8	Y ₁₀
E-11	D ₁₀	L-3	I ₆	G-11	T ₁	A-10	Y ₁₁
F-11	D ₁₁	K-3	I ₇	G-10	T ₂	B-10	Y ₁₂
F-10	D ₁₂	L-2	I ₈	K-11	T ₃	C-10	Y ₁₃
H-10	D ₁₃	K-2	I ₉	K-10	T ₄	C-11	Y ₁₄
J-11	D ₁₄	K-1	I ₁₀	L-5	VCC	D-10	Y ₁₅

VCC are power connections for the logic.
VCC₀ are power connections for the output drivers.

LOGIC SYMBOL

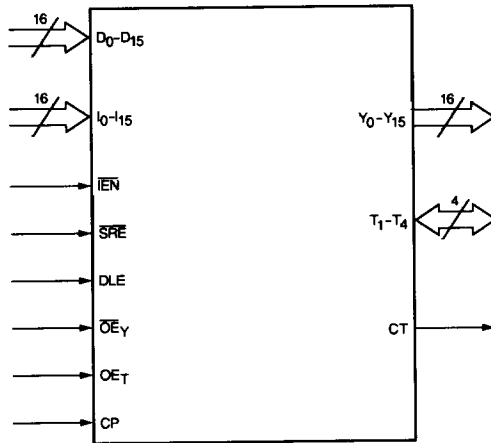

LS002610

METALLIZATION AND PAD LAYOUT

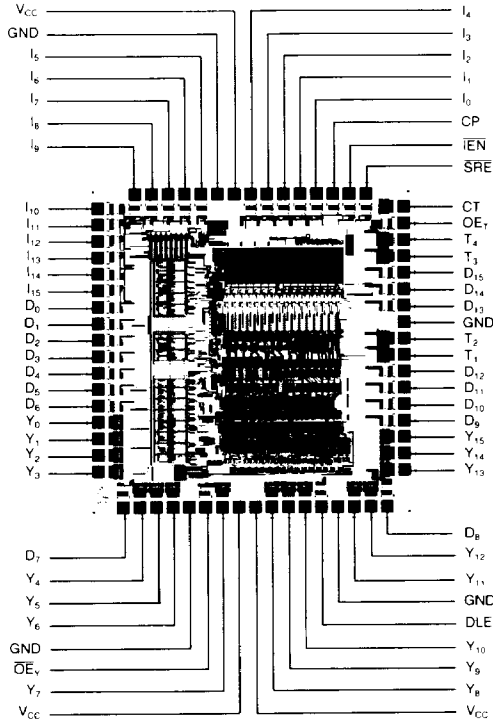

Die Size: 0.184" x 0.184"
Component Count: 14,000

ORDERING INFORMATION

Standard Products

AMD standard products are available in several packages and operating ranges. The order number (Valid Combination) is formed by a combination of:

- A. Device Number**
- B. Speed Option** (if applicable)
- C. Package Type**
- D. Temperature Range**
- E. Optional Processing**

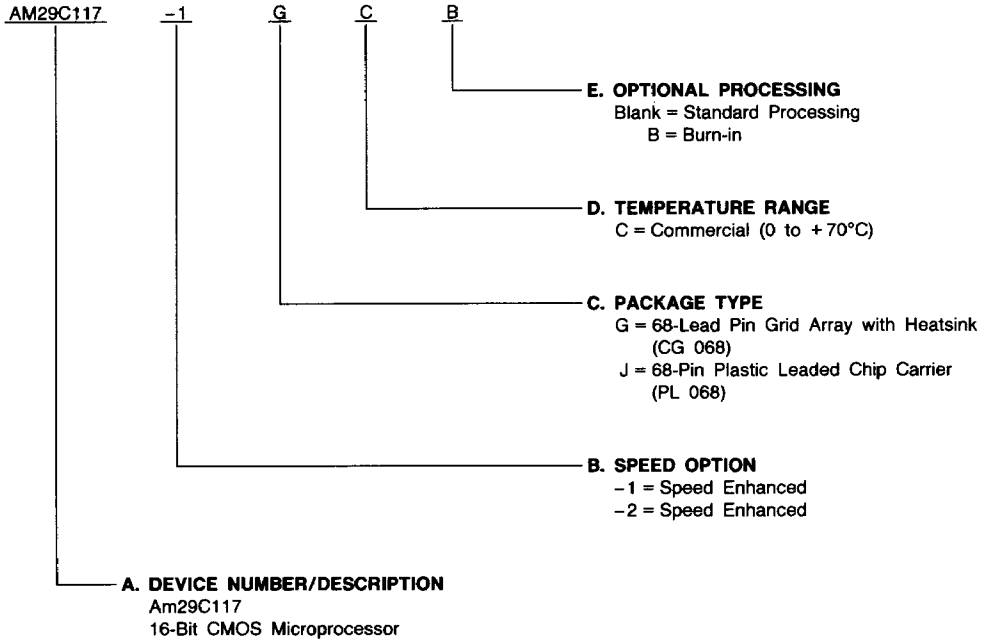

Valid Combinations	
AM29C117	GC, GCB, JC
AM29C117-1	
AM29C117-2	

Valid Combinations

Valid Combinations list configurations planned to be supported in volume for this device. Consult the local AMD sales office to confirm availability of specific valid combinations, to check on newly released combinations, and to obtain additional data on AMD's standard military grade products.

MILITARY ORDERING INFORMATION

APL Products

AMD products for Aerospace and Defense applications are available in several packages and operating ranges. APL (Approved Products List) products are fully compliant with MIL-STD-883C requirements. The order number (Valid Combination) is formed by a combination of:

- a. **Device Number**
- b. **Speed Option** (if applicable)
- c. **Device Class**
- d. **Package Type**
- e. **Lead Finish**

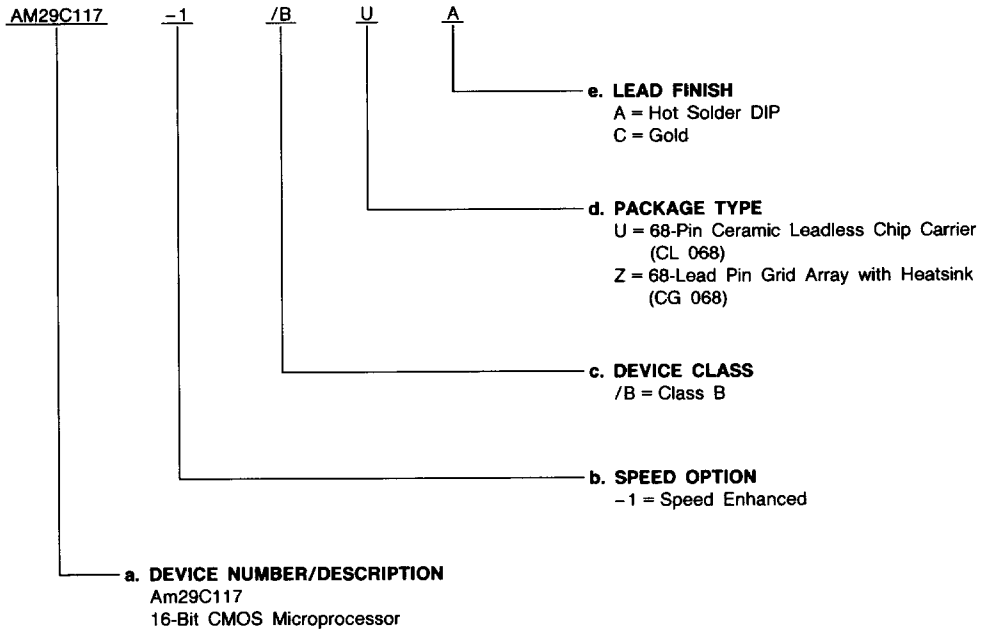

Valid Combinations	
AM29C117-1	/BUA, /BZC

Valid Combinations

Valid Combinations list configurations planned to be supported in volume for this device. Consult the local AMD sales office to confirm availability of specific valid combinations or to check for newly released valid combinations.

Group A Tests

Group A tests consist of Subgroups
1, 2, 3, 7, 8, 9, 10, 11.

PIN DESCRIPTION

D₀–D₁₅ Data Input Lines (Input)

D₀–D₁₅ are used as external data inputs which allow data to be directly loaded into the 16-Bit Data Latch.

Y₀–Y₁₅ Data Output Lines (Output)

When \overline{OE}_Y is HIGH, the 16-bit Y outputs are disabled (high impedance); having \overline{OE}_Y LOW allows the ALU data to be output on Y₀–Y₁₅.

DLE Data Latch Enable (Input)

When DLE is HIGH, the 16-Bit Data Latch is transparent and is latched when DLE is LOW.

\overline{OE}_Y Output Enable (Input)

When \overline{OE}_Y is HIGH, the 16-bit Y outputs are disabled (high impedance); when \overline{OE}_Y is LOW, the 16-bit Y outputs are enabled.

I₀–I₁₅ Instruction Inputs (Input)

Sixteen Instruction Inputs, used to select the operation to be performed in the Am29C117. Also used as data inputs while performing immediate instructions.

\overline{IEN} Instruction Enable (Input)

When \overline{IEN} is LOW, data can be written into RAM when the clock is LOW. The Accumulator can accept data during the LOW-to-HIGH transition of the clock. Having \overline{IEN} LOW, the Status Register can be updated when \overline{SRE} is LOW. With \overline{IEN} HIGH, the conditional test output, CT, is disabled as a function of the instruction inputs.

\overline{SRE} Status Register Enable (Input)

When \overline{SRE} and \overline{IEN} are both LOW, the Status Register is updated at the end of all instructions with the exception of

NO-OP, Save Status, and Test Status. Having either \overline{SRE} or \overline{IEN} HIGH will inhibit the Status Register from changing.

Clock Pulse (Input)

The clock input to the Am29C117. The RAM latch is transparent when the clock is HIGH. When the clock goes LOW, the RAM output is latched. Data is written into the RAM during the LOW period of the clock, provided \overline{IEN} is LOW, and if the instruction being executed designates the RAM as the destination of operation. The Accumulator and Status Register will accept data on the LOW-to-HIGH transition of the clock if \overline{IEN} is also LOW. The Instruction Latch becomes transparent when it exits an immediate instruction mode during a LOW-to-HIGH transition of the clock.

T₁–T₄ Test I/O Pins (Input/Output)

Under the control of OE_T , the four lower status bits, Z, C, N, and OVR become outputs on T₁–T₄, respectively, when OE_T goes HIGH. When OE_T is LOW, T₁–T₄ are used as inputs to generate the CT output.

OE_T Output Enable (Input)

When OE_T is LOW, 4-bit T outputs are disabled (high impedance); when OE_T is HIGH, the 4-bit T outputs are enabled.

CT Conditional Test (Output)

The condition code multiplexer selects one of the twelve condition code signals and places it on the CT output. A HIGH on the CT output indicates a passed condition and a LOW indicates a failed condition.

Suggestions for Power and Ground Pin Connections

The Am29C117 operates in an environment of fast signal rise times and substantial switching currents. Therefore, care must be exercised during circuit board design and layout, as with any high-performance component. The following is a suggested layout, but since systems vary widely in electrical configuration, an empirical evaluation of the intended layout is recommended.

The V_{CC0} pin, which carries output driver switching currents, tends to be electrically noisy. The V_{CC} pins, which supply the internal logic of the device, tend to produce less noise, and the circuits they supply may be adversely affected by noise spikes on the V_{CC} plane. For this reason, it is best to provide isolation between the V_{CC0} and V_{CC} pins, as well as independent decoupling for each; isolating the GND pins is not required.

Printed Circuit Board Layout Suggestions

1. Use of a multilayer PC board with separate V_{CC} , GND, and signal planes is highly recommended.
2. The V_{CC0} and V_{CC} pins should be connected to the V_{CC} plane. The V_{CC0} pin should be isolated from the V_{CC} pins by means of a slot cut in the V_{CC} plane (see suggested layout diagram that follows). By physically separating the V_{CC0} and V_{CC} pins, coupled noise will be reduced.
3. All GND pins should be connected directly to the ground plane.
4. The V_{CC0} pin should be decoupled to ground with a 0.1- μF ceramic capacitor and a 10- μF electrolytic capacitor, placed as closely to the Am29C117 as is practical. The V_{CC} pins should be decoupled to ground in a similar manner.

A suggested layout is shown below:

Bottom View

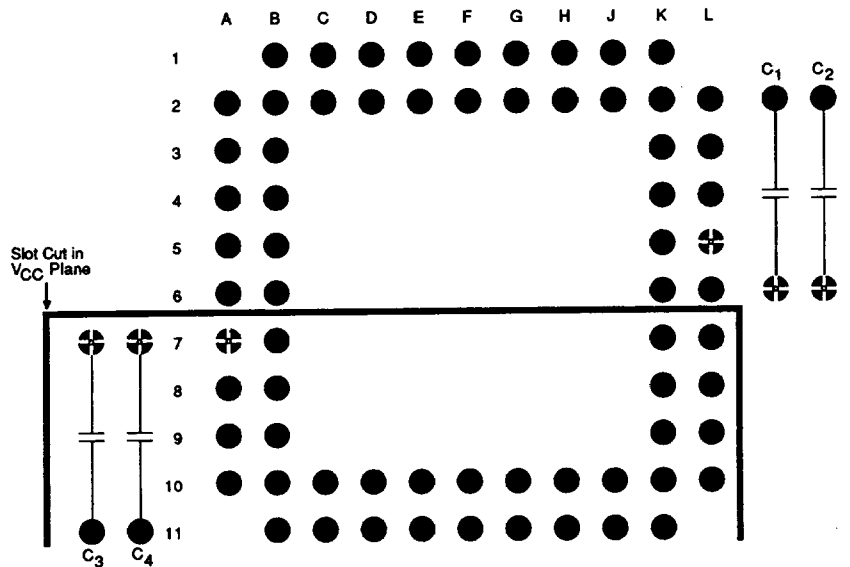

- = V_{CC} Plane Connection
- = Through Hole
- $C_1 = C_3 = 0.1 \mu\text{F}$
- $C_2 = C_4 = 10 \mu\text{F}$

076680-002A

CD011690

Suggested PC Board Layout

FUNCTIONAL DESCRIPTION

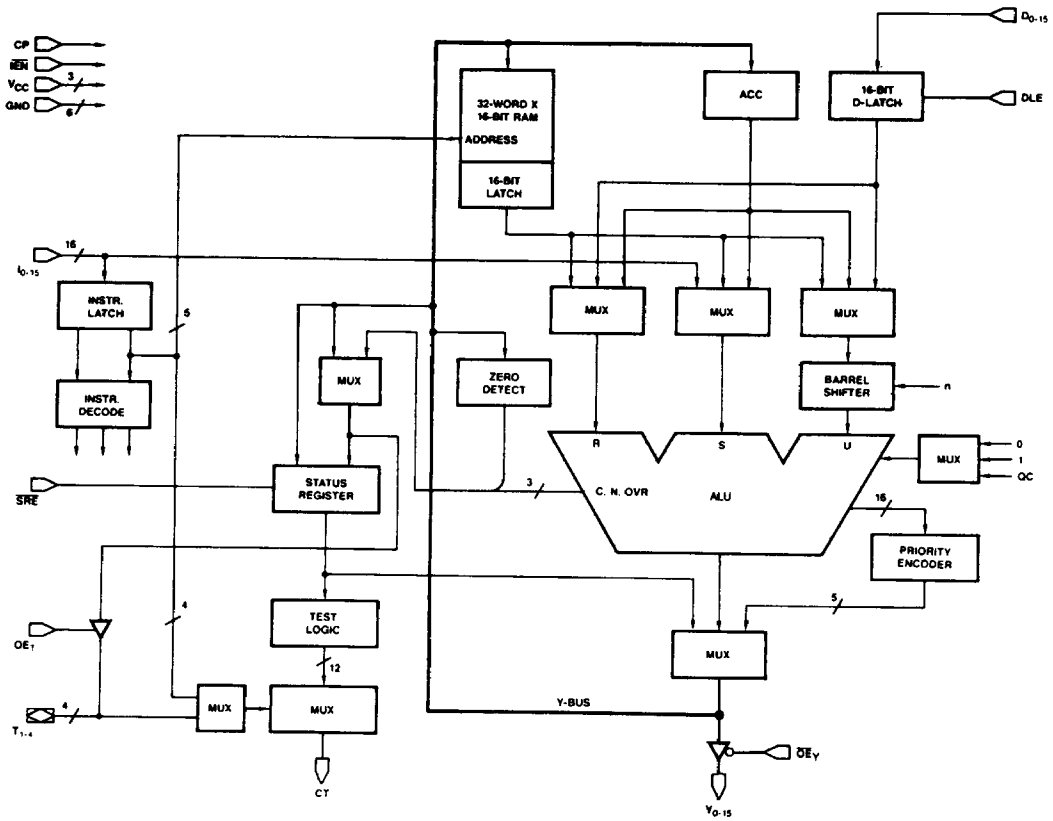

BD001966

Figure 1. Detailed Block Diagram

Architecture of the Am29C117

The Am29C117 is a high-performance, microprogrammable 16-bit CMOS microprocessor.

As shown in the Detailed Block Diagram (Figure 1), the device consists of the following elements interconnected with 16-bit data paths.

- 32-Word by 16-Bit RAM
- Accumulator
- Data Latch
- Barrel Shifter
- Arithmetic Logic Unit (ALU)
- Priority Encoder
- Status Register
- Condition-Code Generator/Multiplexer
- Three-State Output Buffers
- Instruction Latch and Decoder

32-Word by 16-Bit RAM

The 32-Word by 16-Bit RAM is a single-port RAM with a 16-bit latch at its output. The latches are transparent when the clock input (CP) is HIGH and latched when the clock input is LOW. Data is written into the RAM while the clock is LOW if the \overline{IEN} input is also LOW and if the instruction being executed defines the RAM as the destination of the operation. For byte instructions, only the lower 8 RAM bits are written into; for word instructions, all 16 bits are written into. With the use of an external multiplexer on five of the instruction inputs, it is possible to select separate read and write addresses for the same instruction.

Accumulator

The 16-bit Accumulator is an edge-triggered register. The Accumulator accepts data on the LOW-to-HIGH transition of the clock input if the \overline{IEN} input is LOW and if the instruction being executed defines the Accumulator as the destination of the operation. For byte instructions, only the lower 8 bits of the Accumulator are written into; for word instructions, all 16 bits are written into.

Data Latch

The 16-bit Data Latch holds the data input to the Am29C117 on the D bus. The latch is transparent when the DLE input is HIGH and latched when the DLE input is LOW.

Barrel Shifter

A 16-bit Barrel Shifter is used as one of the ALU inputs. This permits rotating data from either the RAM, the Accumulator, or the Data Latch up to 15 positions. In the word mode, the Barrel Shifter rotates a 16-bit word; in the byte mode, it rotates only the lower 8 bits.

Arithmetic Logic Unit (ALU)

The Am29C117 contains a 16-bit ALU with full carry lookahead across all 16 bits in the arithmetic mode. The ALU is capable of operating on either one, two, or three operands, depending upon the instruction being executed. It has the ability to execute all conventional one- and two-operand operations, such as pass, complement, two's complement, add, subtract, AND, NAND, OR, NOR, EXOR, and EX-NOR. In addition, the ALU can also execute three-operand instructions such as Rotate and Merge, and Rotate and Compare with Mask. All ALU operations can be performed on either a word or byte basis; byte operations being performed on the lower eight bits only.

The ALU produces three status outputs, C (carry), N (negative), and OVR (overflow). The appropriate flags are generated at the byte or word level, depending upon whether the device is executing in the byte or word mode. The Z (zero) flag,

although not generated by the ALU, detects zero at both the byte and word level.

The carry input to the ALU is generated by the Carry Multiplexer, which can select an input of zero, one, or the stored carry bit from the Status Register, QC. Using QC as the carry input allows execution of multiprecision addition and subtractions.

Priority Encoder

The Priority Encoder produces a binary-weighted code to indicate the locations of the highest order ONE at its input. The input to the Priority Encoder is generated by the ALU which performs an AND operation on the operand to be prioritized and a mask. The mask determines which bit locations to eliminate from prioritization. In the word mode, if no bit is HIGH, the output is a binary zero. If bit 15 is HIGH, the output is a binary one. Bit 14 produces a binary two, etc. Finally, if only bit 0 is HIGH, a binary 16 is produced.

In the byte mode, bits 8 through 15 do not participate. If none of bits 7 through 0 are HIGH, the output is a binary zero. If bit 7 is HIGH, a binary one is produced. Bit 6 produces a binary two, etc. Finally, if only bit 0 is HIGH, a binary 8 is produced.

Status Register

The Status Register holds the 8-bit status word. With the Status-Register Enable (SRE) input LOW and the \overline{IEN} input LOW, the Status Register is updated at the end of all instructions except NO-OP, Save-Status, and Test-Status instructions. SRE going HIGH or \overline{IEN} going HIGH inhibits the Status Register from changing.

The lower four bits of the Status Register contain the ALU status bits of Zero (Z), Carry (C), Negative (N), and Overflow (OVR). The upper four bits contain a Link bit and three user-definable status bits (Flag1, Flag2, Flag3).

With SRE LOW and \overline{IEN} LOW, the lower four status bits are updated after each instruction except those mentioned above: NO-OP, Save Status, Status Test, and the Status Set/Reset instruction for the upper four bits. Under the same conditions, the upper four status bits are changed only during their respective Status Set/Reset instructions and during Status Load instructions in the word mode. The Link-Status bit is also updated after each shift instruction.

The Status Register can be loaded from the internal Y-Bus, and can also be selected as a source for the internal Y-Bus. When the Status Register is loaded in the word mode, all 8 bits are updated; in the byte mode, only the lower 4 bits (Z, C, N, OVR) are updated.

When the Status Register is selected as a source in the word mode, all eight bits are loaded into the lower byte of the destination; the upper byte of the destination is loaded with all zeros. In the byte mode, the Status Register again loads into the lower byte of the destination, but the upper byte remains unchanged. This Store and Load combination allows saving and restoring the Status Register for interrupt and subroutine processing. The four lower status bits (Z, C, N, OVR) can be read directly via the bidirectional T-Bus. These four bits are available as outputs on the T₁₋₄ outputs whenever OE_T is HIGH.

Condition-Code Generator/Multiplexer

The Condition-Code Generator/Multiplexer contains the logic necessary to develop the 12 condition-code test signals. The multiplexer portion can select one of these test signals and place it on the CT output for use by the microprogram sequencer. The Multiplexer may be addressed in two different ways. One way is through the Test Instruction. This instruction specifies the test condition to be placed in the CT output, but

does not allow an ALU operation at the same time. The second method uses the bidirectional T-Bus as an input. This requires extra bits in the microword, but provides the ability to simultaneously test and execute. The test instruction lines, I_{0-4} , have priority over T_{1-4} for testing status.

Three-State Output Buffers

There are two sets of Three-State Output Buffers in the Am29C117. One set controls the 16-bit Y-Bus. These outputs are enabled by placing a LOW on the \overline{OE}_Y input.

The second set of Three-State Output Buffers controls the bidirectional 4-bit T-Bus and is enabled by placing a HIGH on the OE_T input. This allows storing the four internal ALU status bits (Z, C, N, OVR) externally. A LOW OE_T input forces the T outputs into the high-impedance state. External devices can then drive the T-Bus to select a test condition for the CT output.

Instruction Set

The instruction set of the Am29C117 is very powerful. In addition to the single- and two-operand logical and arithmetic instructions, the Am29C117 instruction set contains functions particularly useful in controller applications: bit set, bit reset, bit test, rotate and merge, rotate and compare, and cyclic-redundancy-check (CRC) generation. Complex instructions like Rotate and Merge, Rotate and Compare, and Prioritize are executed in a single microcycle.

Three data types are supported by the Am29C117.

- Bit
- Byte
- Word (16-bit)

In the byte mode data is written into the lower half of the word and the upper half is unchanged. The special case is when the Status Register is specified as the destination. In the byte mode, the LSH (OVR, N, C, Z) of the Status Register is updated; and in the word mode, all eight bits of the Status Register are updated. The Status Register does not change for Save Status and Test Status instructions. In the Test

Instruction Latch and Decoder

The 16-bit Instruction Latch is normally transparent to allow decoding of the instruction inputs by the Instruction Decoder into the internal control signals for the Am29C117. All instructions except Immediate Instructions are executed in a single clock cycle.

Immediate instructions require two clock cycles for execution. During the first clock cycle, the Instruction Decoder recognizes that an immediate instruction is being specified and captures the data on the instruction inputs in the Instruction Latch. During the second clock cycle, the data on the instruction inputs is used as one of the operands for the function specified during the first clock cycle. At the end of the second clock cycle, the Instruction Latch is returned to its transparent state.

Status instructions the CT output has the result and the Y-Bus is undefined.

The Am29C117 Instruction Set can be divided into eleven types of instructions. These are:

- Single Operand
- Two Operand
- Single Bit Shift
- Rotate and Merge
- Bit Oriented
- Rotate by n Bits
- Rotate and Compare
- Prioritize
- Cyclic-Redundancy-Check
- Status
- No-Operation (NO-OP)

Each instruction type is arbitrarily divided into quadrants. Two of the sixteen instruction lines decode to four quadrants labeled from 0 to 3. The quadrants were defined mainly for convenience in classification of the instruction set and addressing modes, and can be used together with the opcodes to distinguish the instructions.

The following pages describe each of the instruction types in detail. Table 1 illustrates Operand Source-Destination Combinations for each instruction type.

TABLE 1. OPERAND SOURCE-DESTINATION COMBINATIONS

Instruction Type	Operand Combinations (Note 1)		
	Source (R/S)		Destination
Single Operand	RAM (Note 2)		RAM
	ACC		ACC
	D		Y-Bus
	D(OE)		Status
	D(SE)		ACC and Status
Two Operand	I		
	0		
	Source (R)	Source (S)	Destination
	RAM	ACC	RAM
	RAM	I	ACC
Single Bit Shift	D	RAM	Y-Bus
	D	ACC	Status
	ACC	I	ACC and Status
	D	I	Status
Bit Oriented	Source (U)		Destination
	RAM		RAM
	ACC		ACC
	ACC		Y-Bus
	D		RAM
Rotate By n Bits	Source (R/S)		Destination
	RAM		RAM
	ACC		ACC
	D		Y-Bus
Rotate and Merge	Source (U)		Destination
	RAM		RAM
	ACC		ACC
	D		Y-Bus
Rotate and Compare	Rotated Source (U)	Mask (S)	Non-Rotated Source/ Destination (R)
	D	I	ACC
	D	RAM	ACC
	D	I	RAM
	D	ACC	RAM
No Operation (NO-OP)	ACC	I	RAM
	RAM	I	ACC

Instruction Type	Operand Combinations (Note 1)		
	Source (R)	Mask (S)	Destination
Prioritize (Note 3)	RAM	RAM	RAM
	ACC	ACC	ACC
	D	I	Y-Bus
Cyclic-Redundancy-Check (CRC)	Data In	Destination	Polynomial
	QLINK	RAM	ACC
Set Reset Status	Bits Affected		
	OVR, N, C, Z		
	LINK Flag1 Flag2 Flag3		
Store Status	Source		Destination
	Status		RAM
			ACC Y-Bus
Status Load	Source (R)	Source (S)	Destination
	D	ACC	Status
	ACC	I	Status and ACC
	D	I	
Test Status	Test Condition (CT)		
	$(N \oplus OVR) + Z$		
	$N \oplus OVR$		
	Z		
	OVR		
	Low		
C			
$Z + \bar{C}$			
N			
LINK			
Flag1			
Flag2			
Flag3			
No Operation (NO-OP)	-		

- Notes: 1. When there is no dividing line between the R & S Operand or Source and Destination, the two must be used as a given pair. But where there exists such a separation, any combination of them is possible.
2. In the Single Operand Instruction, RAM cannot be used when both Accumulator (ACC) and Status are designated as a Destination.
3. In the Prioritize Instruction, Operand and Mask must be different sources.

Single Operand Instructions

The Single Operand Instructions contain four indicators: Byte or Word mode, Opcode, Source, and Destination. They are further subdivided into two types. The first type uses RAM as a source or destination or both, and the second type does not use RAM as a source or destination. Both types have different instruction formats as shown below. Under the control of instruction inputs, the desired function is performed on the source and the result is either stored in the specified destination or placed on the Y-Bus, or both. For a special case where

8-bit to 16-bit conversion is needed, the Am29C117 is capable of extending sign bit (D(SE)) or binary zero (D(0E)) over 16 bits in the word mode. The least significant four bits of the Status Register (OVR, N, C, Z) are affected by the function performed in this category. The most significant bits of the Status Register (Flag1, Flag2, Flag3, LINK) are not affected. The only limitation in this type is that the RAM cannot be used as a source when both the Accumulator (ACC) and the Status Register are specified as a destination.

SINGLE OPERAND FIELD DEFINITIONS:

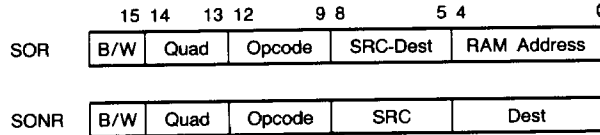

SINGLE OPERAND INSTRUCTION

	15	14	13	12	9	8	5	4	0			
Instruction ¹	B/W ²	Quad ³	Opcode			R/S ⁴ Dest ⁴			RAM Address			
SOR	0 = B 1 = W	10	1100	MOVE	SRC → Dest	0000	SORA	RAM	ACC	00000	R00	RAM Reg 00
			1101	COMP	SRC → Dest	0010	SORY	RAM	Y-Bus
			1110	INC	SRC + 1 → Dest	0011	SORS	RAM	Status	11111	R31	RAM Reg 31
			1111	NEG	SRC + 1 → Dest	0100	SOAR	ACC	RAM			
						0110	SODR	D	RAM			
				0111	SOIR	I	RAM					
				1000	SOZR	0	RAM					
				1001	SOZER	D(0E)	RAM					
				1010	SOSE	D(SE)	RAM					
				1011	SORR	RAM	RAM					
Instruction	B/W	Quad	Opcode			R/S ⁴			Destination			
SONR	0 = B 1 = W	11	1100	MOVE	SRC → Dest	0100	SOA	ACC	00000	NRY	Y-Bus	
			1101	COMP	SRC → Dest	0110	SOD	D	00001	NRA	ACC	
			1110	INC	SRC + 1 → Dest	0111	SOI	I	00100	NRS	Status ⁵	
			1111	NEG	SRC + 1 → Dest	1000	SOZ	0	00101	NRAS	ACC, Status ⁵	
						1001	SOZE	D(0E)				
				1010	SOSE	D(SE)						

- Notes: 1. The instruction mnemonic designates different instruction formats used in the Am29C117. They are useful in microcode assembly.
 2. B = Byte Mode, W = Word Mode.
 3. See Instruction Set description.
 4. R = Source; S = Source; Dest = Destination.
 5. When status is destination,
 Status i - Yi i = 0 to 3 (Byte mode)
 i = 0 to 7 (Word mode)

Y-BUS AND STATUS — SINGLE OPERAND INSTRUCTIONS

Instruction	Opcode	Description	B/W	Y-Bus	Flag3	Flag2	Flag1	LINK	OVR	N	C	Z
SOR SONR	MOVE	SRC → Dest	0 = B	Y → SRC	NC	NC	NC	NC	0	U	0	U
	COMP	SRC → Dest	1 = W	Y → SRC	NC	NC	NC	NC	0	U	0	U
	INC	SRC + 1 → Dest		Y → SRC + 1	NC	NC	NC	NC	U	U	U	U
	NEG	SRC + 1 → Dest		Y → SRC + 1	NC	NC	NC	NC	U	U	U	U

SRC = Source
 U = Update
 NC = No Change

0 = Reset
 1 = Set
 i = 0 to 15 when not specified

Two Operand Instructions

The Two Operand Instructions contain five indicators: Byte or Word mode, Opcode, R Source, S Source, and Destination. They are further subdivided into two types. The first type uses RAM as the source and/or destination and the second type does not use RAM as source or destination. The first type has two formats; the only difference is in the quadrant. Under the control of instruction inputs, the desired function is performed on the specified sources and the result is stored in the

specified destination or placed on the Y-Bus, or both. The least significant four bits of the Status Register (OVR, N, C, Z) are affected by the arithmetic functions performed and only the N and Z bits are affected by the logical functions performed. The OVR and C bits of the Status Register are forced to ZERO for logical functions. Add with carry and Subtract with carry instructions are useful for Multiprecision Add or Subtract.

TWO OPERAND FIELD DEFINITIONS:

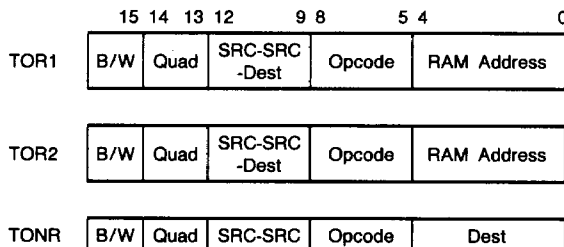

TWO OPERAND INSTRUCTIONS (Cont'd.)

Instruction	B/W	Quad	R ¹	S ¹	Dest ¹	Opcode	RAM Address						
TOR1	0 = B 1 = W	00	0000	TORAA	RAM	ACC	ACC	0000	SUBR	S minus R	00000	R00	RAM Reg 00
			0010	TORIA	RAM	I	ACC	0001	SUBRC ²	S minus R with carry	11111	R31	RAM Reg 31
			0011	TODRA	D	RAM	ACC	0010	SUBS	R minus S			
			1000	TORAY	RAM	ACC	Y-Bus	0011	SUBSC ²	R minus S with carry			
			1010	TORIY	RAM	I	Y-Bus	0100	ADD	R plus S			
			1011	TODRY	D	RAM	Y-Bus	0101	ADDC	R plus S with carry			
			1100	TORAR	RAM	ACC	RAM	0110	AND	$\overline{R \cdot S}$			
			1110	TORIR	RAM	I	RAM	0111	NAND	$\overline{R \cdot S}$			
			1111	TODRR	D	RAM	RAM	1000	EXOR	$\overline{R \oplus S}$			
								1001	NOR	$\overline{R + S}$			
								1010	OR	$\overline{R + S}$			
								1011	EXNOR	$\overline{R \oplus S}$			

Instruction	B/W	Quad	R ¹	S ¹	Dest ¹	Opcode	RAM Address						
TOR2	0 = B 1 = W	10	0001	TODAR	D	ACC	RAM	0000	SUBR	S minus R	00000	R00	RAM Reg 00
			0010	TOAIR	ACC	I	RAM	0001	SUBRC ²	S minus R with carry	11111	R31	RAM Reg 31
			0101	TODIR	D	I	RAM	0010	SUBS	R minus S			
								0011	SUBSC ²	R minus S with carry			
								0100	ADD	R plus S			
								0101	ADDC	R plus S with carry			
								0110	AND	$\overline{R \cdot S}$			
					0111	NAND	$\overline{R \cdot S}$						
					1000	EXOR	$\overline{R \oplus S}$						
					1001	NOR	$\overline{R + S}$						
					1010	OR	$\overline{R + S}$						
					1011	EXNOR	$\overline{R \oplus S}$						

- Notes: 1. R = Source
 S = Source
 Dest = Destination
 2. During subtraction the carry is interpreted as borrow.

TWO OPERAND INSTRUCTIONS

Instruction	B/W	Quad	R ¹	S ¹	Opcode	Destination	
TONR	0 = B 1 = W	11	0001 TODA D ACC 0010 TODA ACC I 0101 TODI D I	0000 0001 0010 0011 0100 0101 0110 0111 1000 1001 1010 1011	ACC I I S S S S S S S S S	0000 SUBR S minus R 0001 SUBRC ³ S minus R with carry 0010 SUBS R minus S 0011 SUBSC ³ R minus S with carry 0100 ADD R plus S 0101 ADDC R plus S with carry 0110 AND R·S 0111 NAND R·S 1000 EXOR R⊕S 1001 NOR R + S 1010 OR R + S 1011 EXNOR R⊕S	00000 NRY Y-Bus 00001 NRA ACC 00100 NRS Status ² 00101 NRAS ACC, Status ²

- Notes: 1. R = Source
S = Source
2. When status is destination,
Status i-Y_i i = 0 to 3 (Byte mode)
i = 0 to 7 (Word mode)
3. During subtraction the carry is interpreted as borrow.

Y-BUS AND STATUS CONTENTS — TWO OPERAND INSTRUCTIONS

Instruction	Opcode	Description	B/W	Y-Bus	Flag3	Flag2	Flag1	LINK	OVR	N	C	Z
TOR1 TOR2 TONR	SUBR	S minus R	0 = B	$Y_{i-1} - S + \bar{R} + 1$	NC	NC	NC	NC	U	U	U	U
	SUBRC	S minus R with carry	1 = W	$Y_{i-1} - S + \bar{R} + QC$	NC	NC	NC	NC	U	U	U	U
	SUBS	R minus S		$Y_{i-1} - R + \bar{S} + 1$	NC	NC	NC	NC	U	U	U	U
	SUBSC	R minus S with carry		$Y_{i-1} - R + \bar{S} + QC$	NC	NC	NC	NC	U	U	U	U
	ADD	R plus S		$Y_{i-1} - R + S$	NC	NC	NC	NC	U	U	U	U
	ADDC	R plus S with carry		$Y_{i-1} - R + S + QC$	NC	NC	NC	NC	U	U	U	U
	AND	R·S		$Y_{i-1} - R_i \text{ AND } S_i$	NC	NC	NC	NC	0	U	0	U
	NAND	$\bar{R} \cdot \bar{S}$		$Y_{i-1} - R_i \text{ NAND } S_i$	NC	NC	NC	NC	0	U	0	U
	EXOR	R⊕S		$Y_{i-1} - R_i \text{ EXOR } S_i$	NC	NC	NC	NC	0	U	0	U
	NOR	$\bar{R} + \bar{S}$		$Y_{i-1} - R_i \text{ NOR } S_i$	NC	NC	NC	NC	0	U	0	U
	OR	R + S		$Y_{i-1} - R_i \text{ OR } S_i$	NC	NC	NC	NC	0	U	0	U
EXNOR	$\overline{R \oplus S}$		$Y_{i-1} - R_i \text{ EXNOR } S_i$	NC	NC	NC	NC	0	0	0	U	

- U = Update
NC = No Change
0 = Reset
1 = Set
i = 0 to 15 when not specified

Single Bit Shift Instructions

The Single Bit Shift Instructions contain four indicators: Byte or Word mode, Direction and Shift Linkage, Source, and Destination. They are further subdivided into two types. The first type uses RAM as the source and/or destination and the second type does not use RAM as source or destination. Under the control of the instruction inputs, the desired shift function is performed on the specified source and the result is stored in the specified destination or placed on the Y-Bus, or both. The direction and shift linkage indicator defines the direction of the shift (up or down) as well as what will be shifted into the vacant bit. On a shift-up instruction, the LSB may be loaded

with ZERO, ONE, or the Link-Status bit (QLINK). The MSB is loaded into the Link-Status bit as shown in Figure 2. On a shift-down instruction, the MSB may be loaded with ZERO, ONE, the contents of the Status Carry flip-flop, (QC), the Exclusive-OR of the Negative-Status bit, and the Overflow-Status bit (QN ⊕ QOVR), or the Link-Status bit. The LSB is loaded into the Link-Status bit as shown in Figure 3. The N and Z bits of the Status Register are affected but the OVR and C bits are forced to ZERO. The Shift-Down with QN ⊕ QOVR is useful for Two's Complement multiplication.

SINGLE BIT SHIFT FIELD DEFINITIONS:

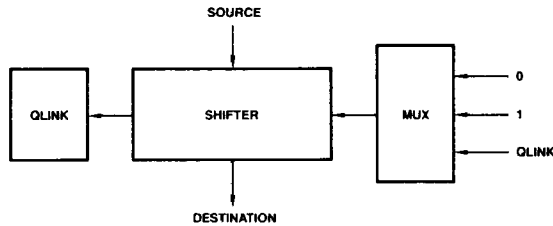
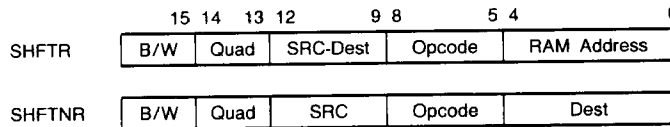

PF000360

Figure 2. Shift-Up Function

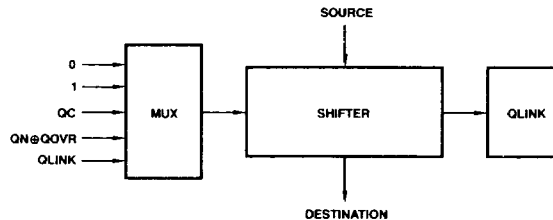

PF000350

Figure 3. Shift-Down Function

SINGLE BIT SHIFT INSTRUCTIONS

Instruction	B/W	Quad	U ¹ Dest ¹				Opcode				RAM Address		
SHFTR	0 = B	10	0110	SHRR	RAM	RAM	0000	SHUPZ	Up	0	00000	R00	RAM Reg 00
	1 = W		0111	SHDR	D	RAM	0001	SHUP1	Up	1
			0010	SHUPL	Up	QLINK	11111	R31	RAM Reg 31				
			0100	SHDNZ	Down	0							
			0101	SHDN1	Down	1							
			0110	SHDNL	Down	QLINK							
			0111	SHDNC	Down	QC							
			1000	SHDNOV	Down	QN⊕QOVR							

Instruction	B/W	Quad	U ¹				Opcode				Destination		
SHFTNR	0 = B	11	0110	SHA	ACC	D	0000	SHUPZ	Up	0	00000	NRY	Y-Bus
	1 = W		0111	SHD	D	D	0001	SHUP1	Up	1	00001	NRA	ACC
			0010	SHUPL	Up	QLINK							
			0100	SHDNZ	Down	0							
			0101	SHDN1	Down	1							
			0110	SHDNL	Down	QLINK							
			0111	SHDNC	Down	QC							
			1000	SHDNOV	Down	QN⊕QOVR							

Note 1. U = Source
Dest = Destination

Y-BUS AND STATUS — SINGLE BIT SHIFT INSTRUCTIONS

Instruction	Opcode	Description	B/W	Y-Bus	Flag3	Flag2	Flag1	LINK	OVR	N	C	Z
SHR SHNR	SHUPZ SHUP1 SHUPL	Up 0	1 = W	Y _i - SRC _{i-1} , i = 1 to 15; Y ₀ - Shift Input	NC	NC	NC	SRC ₁₅ *	0	SRC ₁₄	0	U
		Up 1 Up QLINK		Y _i - SRC _{i-1} , i = 1 to 7; Y ₀ - Shift Input; Y ₈ - SRC ₇ , Y _i - SRC _{i-8} for i = 9 to 15	NC	NC	NC	SRC ₇ *	0	SRC ₆	0	U
	SHDNZ SHDN1 SHDNL SHDNC SHCNOV	Down 0	1 = W	Y _i - SRC _{i+1} , i = 0 to 14; Y ₁₅ - Shift Input	NC	NC	NC	SRC ₀ *	0	Shift Input	0	U
		Down 1 Down QLINK Down QC Down QN⊕QOVR		Y _i - SRC _{i+1} , i = 0 to 6; Y _i - SRC _{i-7} , i = 8 to 14; Y _{7,15} - Shift Input	NC	NC	NC	SRC ₀ *	0	Shift Input	0	U

SRC = Source
U = Update
NC = No Change
0 = Reset
1 = Set
i = 0 to 15 when not specified

*Shifted Output is loaded into the QLINK.

Bit Oriented Instructions

The Bit Oriented Instructions contain four indicators: Byte or Word mode, Operation, Source/Destination, and the Bit Position of the bit to be operated on (Bit 0 is the least significant bit). They are further subdivided into two types. The first type uses the RAM as both source and destination and has two kinds of formats which differ only by quadrant. The second type does not use the RAM as a source or a destination. Under the control of the instruction inputs, the desired function is performed on the specified source and the result is stored in the specified destination or placed on the Y-Bus, or both. The operations which can be performed are: Set Bit n which forces the n^{th} bit to a ONE leaving other bits unchanged; Reset Bit n

which forces the n^{th} bit to ZERO leaving the other bits unchanged; Test Bit n , which sets the ZERO Status Bit depending on the state of bit n leaving all the bits unchanged; Load 2^n , which loads ONE in Bit position n and ZERO in all other bit positions; Load 2^n which loads ZERO in bit position n and ONE in all other bit positions; increment by 2^n , which adds 2^n to the operand; and decrement by 2^n which subtracts 2^n from the operand. For all the Load, Set, Reset and Test instructions, the N and Z bits are affected and OVR and C bit of the Status Register are forced to ZERO. For all arithmetic instructions the LSH (OVR, C, N, Z bits) of the Status Register is affected.

BIT ORIENTED FIELD DEFINITIONS:

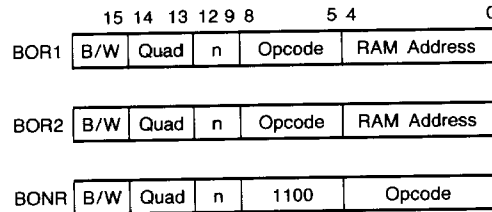

BIT ORIENTED INSTRUCTIONS

Instruction	B/W	Quad	n	Opcode			RAM Address			
BOR1	0 = B 1 = W	11	0 to 15	1101	SETNR	Set RAM, Bit n	00000	R00	RAM Reg 00	
				1110	RSTNR	Reset RAM, Bit n	
				1111	TSTNR	Test RAM, Bit n	11111	R31	RAM Reg 31	
Instruction	B/W	Quad	n	Opcode			RAM Address			
BOR2	0 = B 1 = W	10	0 to 15	1100	LD2NR	2^n → RAM	00000	R00	RAM Reg 00	
				1101	LDC2NR	2^n → RAM	
				1110	A2NR	RAM plus 2^n → RAM	11111	R31	RAM Reg 31	
				1111	S2NR	RAM minus 2^n → RAM				
Instruction	B/W	Quad	n	Opcode						
BONR	0 = B 1 = W	11	0 to 15	1100	00000	TSTNA	Test ACC, Bit n			
					00001	RSTNA	Reset ACC, Bit n			
					00010	SETNA	Set ACC, Bit n			
					00100	A2NA	ACC plus 2^n → ACC			
					00101	S2NA	ACC minus 2^n → ACC			
					00110	LD2NA	2^n → ACC			
					00111	LDC2NA	2^n → ACC			
					10000	TSTND	Test D, Bit n			
					10001	RSTND	Reset D, Bit n			
					10010	SETND	Set D, Bit n			
					10100	A2NDY	D plus 2^n → Y-Bus			
					10101	S2NDY	D minus 2^n → Y-Bus			
					10110	LS2NY	2^n → Y-Bus			
10111	LDC2NY	2^n → Y-Bus								

Y-BUS AND STATUS — BIT ORIENTED INSTRUCTIONS

Instruction	Opcode	Description	B/W	Y-Bus	Flag3	Flag2	Flag1	LINK	OVR	N	C	Z
BOR1	SETNR	Set RAM, Bit n	0 = B	$Y_i \leftarrow RAM_i$ for $i \neq n$; $Y_n \leftarrow 1$	NC	NC	NC	NC	0	U	0	0
	RSTNR	Reset RAM, Bit n	1 = W	$Y_i \leftarrow RAM_i$ for $i \neq n$; $Y_n \leftarrow 0$	NC	NC	NC	NC	0	U	0	U
	TSTNR	Test RAM, Bit n		$Y_i \leftarrow 0$ for $i \neq n$; $Y_n \leftarrow SRC_n$	NC	NC	NC	NC	0	U	0	U
BOR2	LD2NR	$2^n \leftarrow RAM$		$Y_i \leftarrow 0$ for $i \neq n$; $Y_n \leftarrow 1$	NC	NC	NC	NC	0	U	0	0
	LDC2NR	$2^n \leftarrow RAM$		$Y_i \leftarrow 1$ for $i \neq n$; $Y_n \leftarrow 0$	NC	NC	NC	NC	0	U	0	0
	A2NR	$RAM + 2^n \leftarrow RAM$		$Y \leftarrow RAM + 2^n$	NC	NC	NC	NC	U	U	U	U
	S2NR	$RAM - 2^n \leftarrow RAM$		$Y \leftarrow RAM - 2^n$	NC	NC	NC	NC	U	U	U	U
BONR	TSTNA	Test ACC, Bit n		$Y_i \leftarrow 0$ for $i \neq n$; $Y_n \leftarrow ACC_n$	NC	NC	NC	NC	0	U	0	U
	RSTNA	Reset ACC, Bit n		$Y_i \leftarrow ACC_i$ for $i \neq n$; $Y_n \leftarrow 0$	NC	NC	NC	NC	0	U	0	U
	SETNA	Set ACC, Bit n		$Y_i \leftarrow ACC_i$ for $i \neq n$; $Y_n \leftarrow 1$	NC	NC	NC	NC	0	U	0	0
	A2NA	$ACC + 2^n \leftarrow ACC$		$Y \leftarrow ACC + 2^n$	NC	NC	NC	NC	U	U	U	U
	S2NA	$ACC - 2^n \leftarrow ACC$		$Y \leftarrow ACC - 2^n$	NC	NC	NC	NC	U	U	U	U
	LD2NA	$2^n \leftarrow ACC$		$Y_i \leftarrow 0$ for $i \neq n$; $Y_n \leftarrow 1$	NC	NC	NC	NC	0	U	0	0
	LDC2NA	$2^n \leftarrow ACC$		$Y_i \leftarrow 1$ for $i \neq n$; $Y_n \leftarrow 0$	NC	NC	NC	NC	0	U	0	0
	TSTND	Test D, Bit n		$Y_i \leftarrow 0$ for $i \neq n$; $Y_n \leftarrow D_n$	NC	NC	NC	NC	0	U	0	U
	RSTND	Reset D, Bit n*		$Y_i \leftarrow D_i$ for $i \neq n$; $Y_n \leftarrow 0$	NC	NC	NC	NC	0	U	0	U
	SETND	Set D, Bit n*		$Y_i \leftarrow D_i$ for $i \neq n$; $Y_n \leftarrow 1$	NC	NC	NC	NC	0	U	0	0
	A2NDY	$D + 2^n \leftarrow Y-Bus$		$Y \leftarrow D + 2^n$	NC	NC	NC	NC	U	U	U	U
	S2NDY	$D - 2^n \leftarrow Y-Bus$		$Y \leftarrow D - 2^n$	NC	NC	NC	NC	U	U	U	U
	LD2NY	$2^n \leftarrow Y-Bus$		$Y_i \leftarrow 0$ for $i \neq n$; $Y_n \leftarrow 1$	NC	NC	NC	NC	0	U	0	0
	LDC2NY	$2^n \leftarrow Y-Bus$		$Y_i \leftarrow 1$ for $i \neq n$; $Y_n \leftarrow 0$	NC	NC	NC	NC	0	U	0	0

SRC = Source
 U = Update
 NC = No Change
 0 = Reset
 1 = Set
 i = 0 to 15 when not specified

*Destination is not D-Latch but Y-Bus.

Rotate By n Bits Instructions

The Rotate By n Bits Instructions contain four indicators: Byte or Word mode, Source, Destination, and the number of places the source is to be rotated. They are further subdivided into two types. The first type uses RAM as a source and/or a destination and the second type does not use RAM as a source or destination. The first type has two different formats and the only difference is in the quadrant. The second type has only one format as shown in the table. Under the control of instruction inputs, the n indicator specifies the number of bit positions the source is to be rotated up (0 to 15), and the result

is either stored in the specified destination or placed on the Y-Bus, or both. An example of this instruction is given in Figure 4. In the Word mode, all 16 bits are rotated up while in the Byte mode, only the lower 8 bits (0-7) are rotated up. In the Word mode, a rotate up by n bits is equivalent to a rotate down by (16-n) bits. Similarly, in the Byte mode a rotate up by n bits is equivalent to a rotate down by (8-n) bits. The N and Z bits of the Status Register are affected and OVR and C bits are forced to ZERO.

n = 4, Word Mode:

Source	0001	0011	0111	1111
Destination	0011	0111	1111	0001

n = 4, Byte Mode:

Source	0001	0011	0111	1111
Destination	0001	0011	1111	0111

Figure 4. Rotate By n Example

ROTATE BY n BITS FIELD DEFINITIONS:

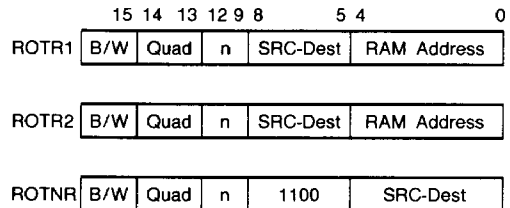

ROTATE BY n BITS INSTRUCTIONS

Instruction	B/W	Quad	n	U ¹		Dest ¹		RAM Address			
ROTR1	0 = B 1 = W	00	0 to 15	1100	RTRA	RAM	ACC	00000	R00	RAM Reg 00	
				1110	RTRY	RAM	Y-Bus	
				1111	RTRR	RAM	RAM	11111	R31	RAM Reg 31	
ROTR2	0 = B 1 = W	01	0 to 15	0000	RTAR	ACC	RAM	00000	R00	RAM Reg 00	
				0001	RTDR	D	RAM	
				1111				11111	R31	RAM Reg 31	
ROTNR	0 = B 1 = W	11	0 to 15	1100				11000	RTDY	D	Y-Bus
								11001	RTDA	D	ACC
								11100	RTAY	ACC	Y-Bus
								11101	RTAA	ACC	ACC

Note: 1. U = Source
Dest = Destination

Y-BUS AND STATUS — ROTATE BY n BITS INSTRUCTIONS

Instruction	Op-code	B/W	Y-Bus	Flag3	Flag2	Flag1	LINK	OVR	N	C	Z
ROTR1 ROTR2 ROTNR		1 = W	$Y_i - SRC_{(i-n) \bmod 16}$	NC	NC	NC	NC	0	SRC_{15-n}	0	U
		0 = B	$Y_i - SRC_i + 8 = SRC_{(i-n) \bmod 8}$ for $i = 0$ to 7	NC	NC	NC	NC	0	SRC_{8-n}	0	U

SRC = Source
U = Update
NC = No Change
0 = Reset
1 = Set
i = 0 to 15 when not specified

Rotate and Merge Instructions

The Rotate and Merge Instructions contain five indicators: Byte or Word mode, Rotated Source, Non-Rotated Source/Destination, Mask, and the number of bit positions a source is to be rotated. The function performed by the Rotate and Merge Instruction is illustrated in Figure 5. The rotated source, U, is rotated up by the Barrel Shifter n places. The mask input then selects, on a bit-by-bit basis, the rotated U input or R

input. A ZERO in bit i of the mask will select the ith bit of the R input as the ith output bit, while ONE in bit i will select the ith rotated U input as the output bit. The output word is stored in the non-rotated operand location. The N and Z bits are affected. The OVR and C bits of the Status Register are forced to ZERO. An example of this instruction is given in Figure 6.

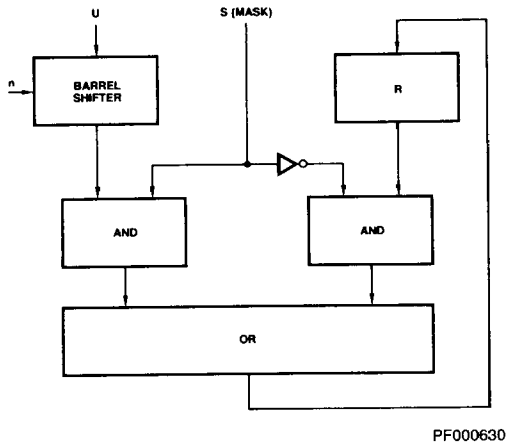

Figure 5. Rotate and Merge Function

n = 4, Word Mode:

U	0011	0001	0101	0110
Rotated U	0001	0101	0110	0011
R	1010	1010	1010	1010
Mask (S)	0000	1111	0000	1111
Destination	1010	0101	1010	0011

Figure 6. Rotate and Merge Example

ROTATE AND MERGE FIELD DEFINITIONS:

	15	14	13	12	9	8		5	4	0
ROTM	B/W	Quad	n	ROT SRC- Non ROT SRC- Mask			RAM Address			

ROTATE AND MERGE INSTRUCTION

Instruction	B/W	Quad	n	U ¹			R/Dest ¹	S ¹	RAM Address		
ROTM	0 = B 1 = W	01	0 to 15	0111	MDAI	D	ACC	I	00000	R00	RAM Reg 00
				1000	MDAR	D	ACC	RAM			RAM
				1001	MDRI	D	RAM	I			RAM
				1010	MDRA	D	RAM	ACC			ACC
				1100	MARI	ACC	RAM	I			RAM
				1110	MRAI	RAM	ACC	I			I
								11111	R31	RAM Reg 31	

U = Rotated Source
R/Dest = Non-Rotated Source and Destination
S = Mask

Y-BUS AND STATUS — ROTATE AND MERGE INSTRUCTIONS

Instruction	Opcode	B/W	Y-Bus	Flag3	Flag2	Flag1	LINK	OVR	N	C	Z
ROTM		1=W	$Y_i - (\text{Non Rot Op})_i \cdot (\text{mask})_i + (\text{Rot Op})_{(i-n) \bmod 16} \cdot (\text{mask})_i$	NC	NC	NC	NC	0	U	0	U
		0=B	$Y_i - (\text{Non Rot Op})_i \cdot (\text{mask})_i + (\text{Rot Op})_{(i-n) \bmod 8} \cdot (\text{mask})_i$	NC	NC	NC	NC	0	U	0	U

U = Update
NC = No Change
0 = Reset
1 = Set
i = 0 to 15 when not specified

Rotate and Compare Instructions

The Rotate and Compare Instructions contain five indicators: Byte or Word mode, Rotated Source, Non-Rotated Source, Mask, and the number of bit positions the rotated source is to be rotated up. Under the control of instruction inputs, the function performed by the Rotate and Compare Instruction is illustrated in Figure 7. The rotated operand is rotated by the Barrel Shifter n places. The mask is inverted and ANDed on a

bit-by-bit basis with the output of the Barrel Shifter and R input. Thus, a ONE in the mask input eliminates that bit from the comparison. A ZERO allows the comparison. If the comparison passes, the Zero flag is set. If it fails, the Zero flag is reset. The N and Z bit are affected. The OVR and C bits of the Status Register are forced to ZERO. An example of this instruction is given in Figure 8.

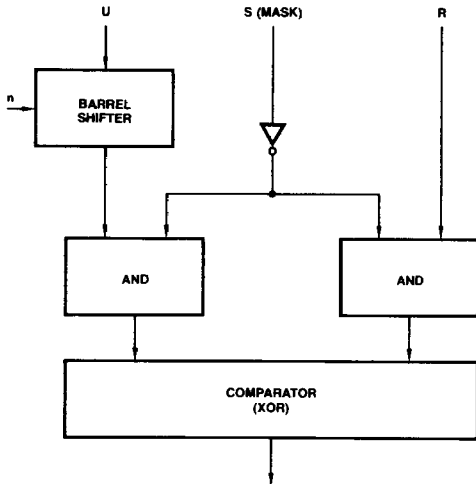

PF000650

Figure 7. Rotate and Compare Function

$n = 4$, Word Mode

U	0011	0001	0101	0110
U Rotated	0001	0101	0110	0011
R	0001	0101	1111	0000
Mask (S)	0000	0000	1111	1111
Z (status) = 1				

Figure 8. Rotate and Compare Example

ROTATE AND COMPARE FIELD DEFINITIONS:

	15	14	13	12	9	8	5	4	0
ROTC	B/W		Quad	n	Rot Src- Non Rot Src- Mask		RAM Address		

ROTATE AND COMPARE INSTRUCTIONS

Instruction	B/W	Quad	n	U ¹	R ¹	S ¹	RAM Address				
ROTC	0 = B 1 = W	01	0 to 15	0010	CDAI	D	ACC	I	00000	R00	RAM Reg 00
				0011	CDRI	D	RAM	I
				0100	CDRA	D	RAM	ACC	11111	R31	RAM Reg 31
				0101	CRAI	RAM	ACC	I			

U = Rotated Source
R = Non-Rotated Source
S = Mask

Y-BUS AND STATUS — ROTATE AND COMPARE INSTRUCTIONS

Instruction	Opcode	B/W	Y-Bus	Flag3	Flag2	Flag1	LINK	OVR	N	C	Z
ROTC		1 = W	$Y_i - (\text{Non Rot Op})_i \cdot (\text{mask})_i \oplus (\text{Rot Op})_{(i-n)\text{mod } 16} \cdot (\text{mask})_i$	NC	NC	NC	NC	0	U	0	U
		0 = B	$Y_i - (\text{Non Rot Op})_i \cdot (\text{mask})_i \oplus (\text{Rot Op})_{(i-n)\text{mod } 8} \cdot (\text{mask})_i$	NC	NC	NC	NC	0	U	0	U

U = Update
NC = No Change
0 = Reset
1 = Set
 $i = 0$ to 15 when not specified

Prioritize Instructions

The Prioritize Instructions contain four indicators: Byte or Word mode, Operand Source (R), Mask Source (S), and Destination. They are further subdivided into two types. The function performed by the Prioritize instruction is shown in Figure 9. The R operand is ANDed with the complement of the Mask operand. A ZERO in the Mask operand allows the corresponding bit in the R operand to participate in the priority encoding function. A ONE in the Mask operand forces the corresponding bit in the R operand to a ZERO, eliminating it from participation in the priority encoding function.

The Priority Encoder accepts a 16-bit input and produces a 5-bit binary-weighted code indicating the bit position of the highest-priority active bit. If none of the inputs are active, the output is ZERO. In the Word mode, if input bit 15 is active, the output is 1, etc. Figure 10 lists the output as a function of the highest-priority active-bit position in both the Word and Byte mode. The N and Z bits are affected and the OVR and C bits of the Status Register are forced to ZERO. The only limitation in this instruction is that the operand and the mask must be different sources.

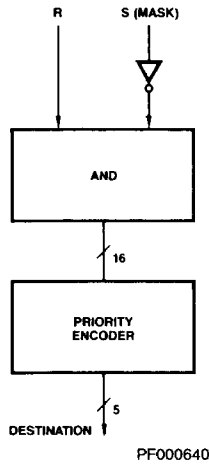

Figure 9. Prioritize Function

WORD MODE		BYTE MODE*	
Highest Priority Active Bit	Encoder Output	Highest Priority Active Bit	Encoder Output
None	0	None	0
15	1	7	1
14	2	6	2
.	.	.	.
.	.	.	.
1	15	1	7
0	16	0	8

*Bits 8 through 15 do not participate

Figure 10. Encoder Output

PRIORITIZE FIELD DEFINITIONS:

15 14 13 12		9 8		5 4		0
B/W	Quad	Destination	Source (R)	RAM Address/	Mask (S)	
B/W	Quad	Mask (S)	Destination	RAM Address/	Source (R)	
B/W	Quad	Mask (S)	Source (R)	RAM Address/	Destination	
B/W	Quad	Mask (S)	Source (R)	Destination		

PRIORITIZE INSTRUCTION

Instruction	B/W	Quad	Destination			Source (R)			RAM Address/Mask (S)		
PRT1	0 = B 1 = W	10	1000 1010 1011	PRA PR1Y PR1R	ACC Y-Bus RAM	0111 1001	RPT1A PR1D	ACC D	00000 .. 11111	R00 .. R31	RAM Reg 00 RAM Reg 31
Instruction	B/W	Quad	Mask (S)			Destination			RAM Address/Source (R)		
PRT2	0 = B 1 = W	10	1000 1010 1011	PRA PRZ PRI	Acc 0 I	0000 0010	PR2A PR2Y	ACC Y-Bus	00000 .. 11111	R00 .. R31	RAM Reg 00 RAM Reg 31
Instruction	B/W	Quad	Mask (S)			Source (R)			RAM Address/Dest		
PRT3	0 = B 1 = W	10	1000 1010 1011	PRA PRZ PRI	ACC 0 I	0011 0100 0110	PR3R PR3A PR3D	RAM ACC D	00000 .. 11111	R00 .. R31	RAM Reg 00 RAM Reg 31
Instruction	B/W	Quad	Mask (S)			Source (R)			Destination		
PRTNR	0 = B 1 = W	11	1000 1010 1011	PRA PRZ PRI	ACC 0 I	0100 0110	PRTA PRTD	ACC D	00000 00001	NRY NRA	Y-Bus ACC

Y-BUS AND STATUS — PRIORITIZE INSTRUCTIONS

Instruction	Opcode	B/W	Y-Bus	Flag3	Flag2	Flag1	LINK	OVR	N	C	Z
PRT1 PRT2		1 = W	$Y_j = \text{CODE}(\text{SCR}_n, \text{mask}_n)$; $Y_m = 0$; $i = 0$ to 4 and $n = 0$ to 15 $m = 5$ to 15	NC	NC	NC	NC	0	U	0	U
PRT3 PRTNR		0 = B	$Y_j = \text{CODE}(\text{SCR}_n, \text{mask}_n)$; $Y_m = 0$; $i = 0$ to 3 and $n = 0$ to 7 $m = 4$ to 15	NC	NC	NC	NC	0	U	0	U

SRC = Source
U = Update

NC = No Change
0 = Reset

1 = Set
 $i = 0$ to 15 when not specified

Cyclic-Redundancy-Check Instructions

The Cyclic-Redundancy-Check (CRC) Instructions contain one indicator: Address of a RAM register to use as the check sum register. The CRC Instruction provides a method for generation of the check bits in a CRC calculation. Two CRC Instructions are provided – CRC Forward and CRC Reverse. The reason for providing two instructions is that CRC standards do not specify which data bit is to be transmitted first, the LSB or the MSB, but they do specify which check bit must be transmitted first. Figure 11 illustrates the method used to generate these check bits for the CRC Forward function, and

Figure 12 illustrates the method used for the CRC Reverse function. The ACC serves as a polynomial mask to define the generating polynomial while the RAM register holds the partial result and eventually the calculated check sum. The LINK-bit is used as the serial input. The serial input combines with the MSB of the check-sum register, according to the polynomial defined by the polynomial mask register. When the last input bit has been processed, the check-sum register contains the CRC check bits. The LINK, N, and Z bits are affected and the OVR and C bits of the Status Register are forced to ZERO.

CYCLIC-REDUNDANCY-CHECK FIELD DEFINITIONS:

	15	14	13	12	9	8	5	4	0
CRCF	1	Quad	0110	0011	RAM Address				
CRCR	1	Quad	0110	1001	RAM Address				

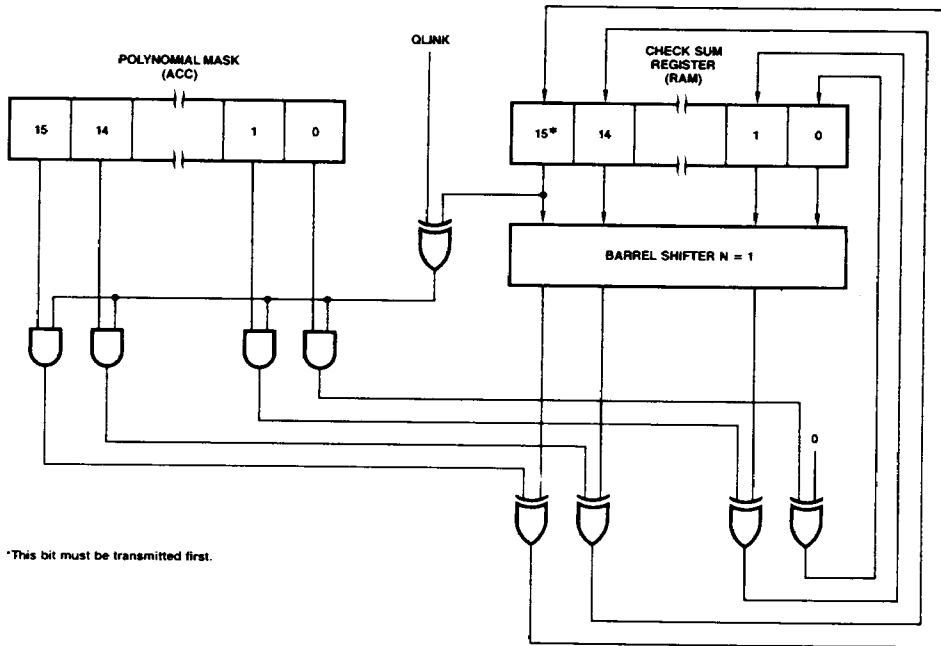

*This bit must be transmitted first.

PF000330

Figure 11. CRC Forward Function

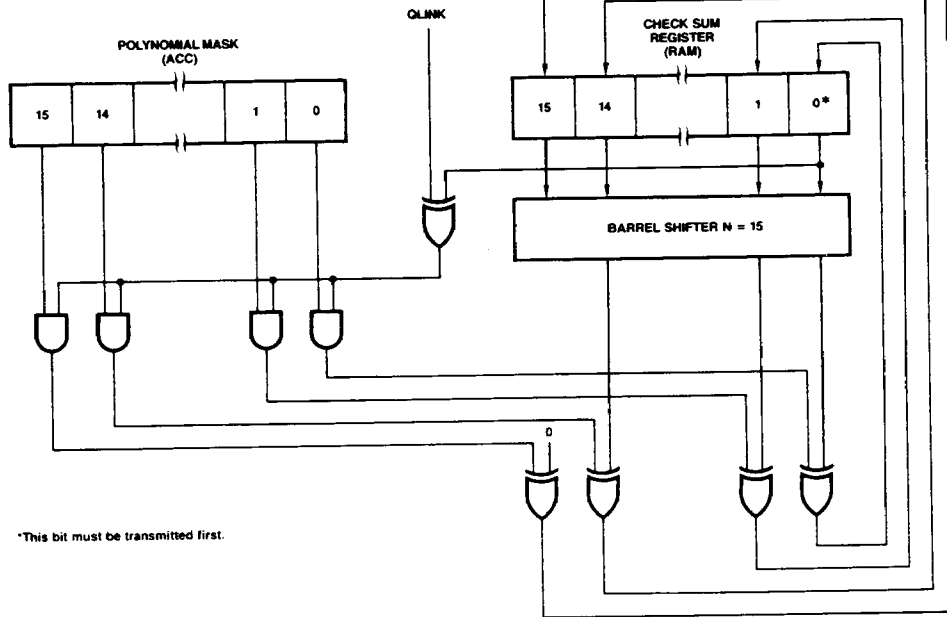

*This bit must be transmitted first.

PF000320

Figure 12. CRC Reverse Function

CYCLIC-REDUNDANCY-CHECK INSTRUCTIONS

Instruction	B/W	Quad			RAM Address		
CRCF	1	10	0110	0011	00000	R00	RAM Reg 00
					11111	R31	RAM Reg 31
CRCR	1	10	0110	1001	00000	R00	RAM Reg 00
					11111	R31	RAM Reg 31

Y-BUS AND STATUS — CYCLIC-REDUNDANCY-CHECK INSTRUCTIONS

Instruction	Opcode	B/W	Y-Bus	Flag3	Flag2	Flag1	LINK	OVR	N	C	Z
CRCF		1 = W	$Y_i = [(QLINK \oplus RAM_{15}) \cdot ACC_i]$ $\oplus RAM_{i-1}$ for $i = 15$ to 1 $Y_0 = [(QLINK \oplus RAM_{15}) \cdot ACC_0] \oplus 0$	NC	NC	NC	RAM ₁₅ *	0	U	0	U
CRCR		1 = W	$Y_i = [(QLINK \oplus RAM_0) \cdot ACC_i]$ $\oplus RAM_{i+1}$ for $i = 14$ to 0 $Y_{15} = [(QLINK \oplus RAM_0) \cdot ACC_{15}] \oplus 0$	NC	NC	NC	RAM ₀ *	0	U	0	U

*QLINK is loaded with the shifted out bit from the check-sum register.

U = Update
 NC = No Change
 0 = Reset
 1 = Set
 i = 0 to 15 when not specified

Status Instructions

The Set Status Instruction contains a single indicator. This indicator specifies which bit or group of bits, contained in the Status Register (Figure 13), are to be set (forced to a ONE).

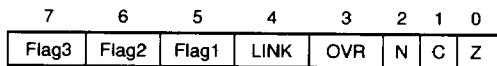

MPR-775

Figure 13. Status Byte

The Reset Status Instruction contains a single indicator. This indicator specifies which bit or group of bits, contained in the Status Register, are to be reset (forced to ZERO).

The Store Status Instruction contains two indicators; Byte/Word and a second indicator that specifies the destination of the Status Register. The Store Status Instruction allows the status of the processor to be saved and restored later, which is an especially useful function for interrupt handling.

The Status Register is always stored in the lower byte of the RAM or the ACC register. Depending upon byte or word mode, the upper byte is unchanged or loaded with all ZEROS, respectively.

The Load Status instructions are included in the single operand and two operand instruction types.

The Test Status Instructions contain a single indicator which specifies which one of the 12 possible test conditions are to be placed on the Conditional-Test (CT) output. Besides the eight bits in the Status Register (QZ, QC, QN, QOVR, QLINK, QFlag1, QFlag2, and QFlag3), four logical functions ($QN \oplus QOVR$, $(QN \oplus QOVR) + QZ$, $QZ + \bar{Q}C$, and LOW) may also be selected. These functions are useful in testing results of Two's Complement and unsigned number arithmetic operations. The Status Register may also be tested via the bidirectional T-Bus. The code to test the Status Register via T-Bus is similar to the code used by instruction lines I₁ to I₄ as shown below. Instruction lines I₀₋₄ have priority over T-Bus for testing the

Status Register on CT output. See the discussion on the Status Register for a full description.

T ₄ I ₄	T ₃ I ₃	T ₂ I ₂	T ₁ I ₁	CT
0	0	0	0	(N ⊕ OVR) + Z
0	0	0	1	N ⊕ OVR
0	0	1	0	Z
0	0	1	1	OVR
0	1	0	0	LOW
0	1	0	1	C
0	1	1	0	Z + \bar{C}
0	1	1	1	N
1	0	0	0	LINK
1	0	0	1	Flag1
1	0	1	0	Flag2
1	0	1	1	Flag3

STATUS FIELD DEFINITIONS:

	15	14	13	12	9	8	5	4	0
SETST	0	Quad	1011	1010	Opcode				
RSTST	0	Quad	1010	1010	Opcode				
SVSTR	B/W	Quad	0111	1010	RAM Address/Dest				
SVSTNR	B/W	Quad	0111	1010	Destination				

STATUS INSTRUCTIONS

Instruction	B/W	Quad			Opcode		
SETST	0	11	1011	1010	00011 00101 00110 01001 01010	SONCZ SL SF1 SF2 SF3	Set OVR, N, C, Z Set LINK Set Flag1 Set Flag2 Set Flag3
Instruction	B/W	Quad			Opcode		
RSTST	0	11	1010	1010	00011 00101 00110 01001 01010	RONCZ RL RF1 RF2 RF3	Reset OVR, N, C, Z Reset LINK Reset Flag1 Reset Flag2 Reset Flag3
Instruction	B/W	Quad			RAM Address/Dest		
SVSTR	0 = B 1 = W	10	0111	1010	00000 ... 11111	R00 ... R31	RAM Reg 00 ... RAM Reg 31
Instruction	B/W	Quad			Destination		
SVSTNR	0 = B 1 = W	11	0111	1010	00000 00001	NRY NRA	Y-Bus ACC

STATUS INSTRUCTIONS (Cont'd.)

Instruction	B/W	Quad			Opcode (CT)		
Test	0	11	1001	1010	00000	TNOZ	Test (N⊕OVR) + Z
					00010	TNO	Test N⊕OVR
					00100	TZ	Test Z
					00110	TOVR	Test OVR
					01000	TLOW	Test LOW
					01010	TC	Test C
					01100	TZC	Test Z + C̄
					01110	TN	Test N
					10000	TL	Test LINK
					10010	TF1	Test Flag1
					10100	TF2	Test Flag2
					10110	TF3	Test Flag3

Y-BUS AND STATUS — STATUS INSTRUCTIONS

Instruction	Opcode	Description	B/W	Y-Bus	Flag3	Flag2	Flag1	LINK	OVR	N	C	Z
SETST	SONCZ	Set OVR, N, C, Z	0 = B	Y _{i-1} for i = 0 to 15	NC	NC	NC	NC	1	1	1	1
	SL	Set LINK			NC	NC	NC	1	NC	NC	NC	NC
	SF1	Set Flag1			NC	NC	1	NC	NC	NC	NC	NC
	SF2	Set Flag2			NC	1	NC	NC	NC	NC	NC	NC
	SF3	Set Flag3			1	NC	NC	NC	NC	NC	NC	NC
RSTST	RONCZ	Reset OVR, N, C, Z	0 = B	Y _{i+0} for i = 0 to 15	NC	NC	NC	NC	0	0	0	0
	RL	Reset LINK			NC	NC	NC	0	NC	NC	NC	NC
	RF1	Reset Flag1			NC	NC	0	NC	NC	NC	NC	NC
	RF2	Reset Flag2			NC	0	NC	NC	NC	NC	NC	NC
	RF3	Reset Flag3			0	NC	NC	NC	NC	NC	NC	NC
SVSTR SVSTNR		Save Status*	0 = B 1 = W	Y _{i+} Status for i = 0 to 7; Y _{i-0} for i = 8 to 15	NC	NC	NC	NC	NC	NC	NC	
Test	TNOZ	Test (N⊕OVR) + Z	0 = B	**	NC	NC	NC	NC	NC	NC	NC	NC
	TNO	Test N⊕OVR			NC	NC	NC	NC	NC	NC	NC	NC
	TZ	Test Z			NC	NC	NC	NC	NC	NC	NC	NC
	TOVR	Test OVR			NC	NC	NC	NC	NC	NC	NC	NC
	TLOW	Test LOW			NC	NC	NC	NC	NC	NC	NC	NC
	TC	Test C			NC	NC	NC	NC	NC	NC	NC	NC
	TZC	Test Z + C̄			NC	NC	NC	NC	NC	NC	NC	NC
	TN	Test N			NC	NC	NC	NC	NC	NC	NC	NC
	TL	Test LINK			NC	NC	NC	NC	NC	NC	NC	NC
	TF1	Test Flag1			NC	NC	NC	NC	NC	NC	NC	NC
	TF2	Test Flag2			NC	NC	NC	NC	NC	NC	NC	NC
	TF3	Test Flag3			NC	NC	NC	NC	NC	NC	NC	NC

U = Update
 NC = No Change
 0 = Reset
 1 = Set
 i = 0 to 15 when not specified

*In Byte mode only, the lower byte from the Y-Bus is loaded into the RAM or ACC, and in Word mode, all 16 bits from the Y-Bus are loaded into the RAM or ACC.

**Y-Bus is Undefined.

No-Operation (NO-OP) Instruction

The NO-OP Instruction has a fixed 16-bit code. This instruction does not change any internal registers in the Am29C117. It preserves the Status Register, RAM register, and the ACC register.

NO-OP FIELD DEFINITION:

	15	14	13	12	9	8	5	4	0
NO-OP	0	11	1000	1010	00000				

NO-OP INSTRUCTION

Instruction	B/W	Quad			
NO-OP	0	11	1000	1010	00000

Y-BUS AND STATUS — NO-OP INSTRUCTION

Instruction	Opcode	B/W	Y-Bus	Flag3	Flag2	Flag1	LINK	OVR	N	C	Z
NO-OP		0 = B	*	NC	NC	NC	NC	NC	NC	NC	NC

SRC = Source
 U = Update
 NC = No Change
 0 = Reset
 1 = Set
 i = 0 to 15 when not specified
 *Y-Bus is undefined.

SUMMARY OF MNEMONICS

INSTRUCTION TYPE

SOR	Single Operand RAM
SONR	Single Operand Non-RAM
TOR1	Two Operand RAM (Quad 0)
TOR2	Two Operand RAM (Quad 2)
TONR	Two Operand Non-RAM
SHFTR	Single Bit Shift RAM
SHFTNR	Single Bit Shift Non-RAM
ROTR1	Rotate n Bits RAM (Quad 0)
ROTR2	Rotate n Bits RAM (Quad 1)
ROTNR	Rotate n Bits Non-RAM
BOR1	Bit Oriented RAM (Quad 3)
BOR2	Bit Oriented RAM (Quad 2)
BONR	Bit Oriented Non-RAM
ROTM	Rotate and Merge
ROTC	Rotate and Compare
PRT1	Prioritize RAM; Type 1
PRT2	Prioritize RAM; Type 2
PRT3	Prioritize RAM; Type 3
PRTNR	Prioritize Non-RAM
CRCF	Cyclic-Redundancy-Check Forward
CRCR	Cyclic-Redundancy-Check Reverse
NOOP	No Operation
SETST	Set Status
RSTST	Reset Status
SVSTR	Save Status RAM
SVSTNR	Save Status Non-RAM
TEST	Test Status

SOURCE AND DESTINATION

Single Operand:

SORA	Single Operand RAM to ACC
SORY	Single Operand RAM to Y-Bus
SORS	Single Operand RAM to Status
SOAR	Single Operand ACC to RAM
SODR	Single Operand D to RAM
SOIR	Single Operand I to RAM
SOZR	Single Operand 0 to RAM
SOZER	Single Operand D(0E) to RAM
SOSE	Single Operand D(SE) to RAM
SORR	Single Operand RAM to RAM
SOA	Single Operand ACC
SOD	Single Operand D
SOI	Single Operand I
SOZ	Single Operand 0
SOZE	Single Operand D(0E)
SOSE	Single Operand D(SE)
NRY	Non-RAM Y-Bus
NRA	Non-RAM ACC
NRS	Non-RAM Status
NRAS	Non-RAM ACC, Status

Two Operand:

TORAA	Two Operand RAM, ACC to ACC
TORIA	Two Operand RAM, I to ACC
TODRA	Two Operand D, RAM to ACC
TORAY	Two Operand RAM, ACC to Y-Bus
TORIY	Two Operand RAM, I to Y-Bus
TODRY	Two Operand D, RAM to Y-Bus
TORAR	Two Operand RAM, ACC to RAM
TORIR	Two Operand RAM, I to RAM
TODRR	Two Operand D, RAM to RAM
TODAR	Two Operand D, ACC to RAM
TOAIR	Two Operand ACC, I to RAM
TODIR	Two Operand D, I to RAM
TODA	Two Operand D, ACC
TOAI	Two Operand ACC, I
TODI	Two Operand D, I

Single Bit Shift:

SHRR	Shift RAM, Store in RAM
SHDR	Shift D, Store in RAM
SHA	Shift ACC
SHD	Shift D

Rotate By n Bits:

RTRA	Rotate RAM, Store in ACC
RTRY	Rotate RAM, Place on Y-Bus
RTRR	Rotate RAM, Store in RAM
RTAR	Rotate ACC, Store in RAM
RTDR	Rotate D, Store in RAM
RTDY	Rotate D, Place on Y-Bus
RTDA	Rotate D, Store in ACC
RTAY	Rotate ACC, Place on Y-Bus
RTAA	Rotate ACC, Store in ACC

Rotate and Merge:

MDAI	Merge Disjoint Bits of D and ACC Using I as Mask and Store in ACC
MDAR	Merge Disjoint Bits of D and ACC Using RAM as Mask and Store in ACC
MDRI	Merge Disjoint Bits of D and RAM Using I as Mask and Store in RAM
MDRA	Merge Disjoint Bits of D and RAM Using ACC as Mask and Store in RAM
MARI	Merge Disjoint Bits of ACC and RAM Using I as Mask and Store in RAM
MRAI	Merge Disjoint Bits of RAM and ACC Using I as Mask and Store in ACC

Rotate and Compare:

CDAI	Compare Unmasked Bits of D and ACC Using I as Mask
------	--

CDRI Compare Unmasked Bits of D and RAM Using I as Mask
 CDRA Compare Unmasked Bits of D and RAM Using ACC as Mask
 CRAI Compare Unmasked Bits of RAM and ACC Using I as Mask

Prioritize:

PR1A ACC as Destination for Prioritize Type 1
 PR1Y Y-Bus as Destination for Prioritize Type 1
 PR1R RAM as Destination for Prioritize Type 1
 PRT1A ACC as Source for Prioritize Type 1
 PR1D D as Source for Prioritize Type 1
 PR2A ACC as Destination for Prioritize Type 2
 PR2Y Y-Bus as Destination for Prioritize Type 2
 PR3R RAM as Source for Prioritize Type 3
 PR3A ACC as Source for Prioritize Type 3
 PR3D D as Source for Prioritize Type 3
 PRTA ACC as source for Prioritize Type Non-RAM
 PRTD D as Source for Prioritize Type Non-RAM
 PRA ACC as Mask for Prioritize Type 2, 3, and Non-RAM
 PRZ Mask Equal to Zero for Prioritize Type 2, 3, and Non-RAM
 PRI I as Mask for Prioritize Type 2, 3, and Non-RAM

OPCODE

Addition:

ADD Add without Carry
 ADDC Add with Carry
 A2NA Add 2^n to ACC
 A2NR Add 2^n to RAM
 A2NDY Add 2^n to D, Place on Y-Bus

Subtraction:

SUBR Subtract R from S without Carry
 SUBRC Subtract R from S with Carry
 SUBS Subtract S from R without Carry
 SUBSC Subtract S from R with Carry
 S2NR Subtract 2^n from RAM
 S2NA Subtract 2^n from ACC
 S2NDY Subtract 2^n from D, Place on Y-Bus

Logical Operations:

AND Boolean AND
 NAND Boolean NAND
 EXOR Boolean EXOR
 NOR Boolean NOR
 OR Boolean OR
 EXNOR Boolean EXNOR

SHIFTS

SHUPZ Shift Up Towards MSB with 0 Insert
 SHUP1 Shift Up Towards MSB with 1 Insert
 SHUPL Shift Up Towards MSB with LINK Insert

SHDNZ Shift Down Towards LSB with 0 Insert
 SHDN1 Shift Down Towards LSB with 1 Insert
 SHDNL Shift Down Towards LSB with LINK Insert
 SHDNC Shift Down Towards LSB with Carry Insert
 SHDNOV Shift Down Towards LSB with Sign EXOR Overflow Insert

Loads:

LD2NR Load 2^n into RAM
 LDC2NR Load 2^n into RAM
 LD2NA Load 2^n into ACC
 LDC2NA Load 2^n into ACC
 LD2NY Place 2^n on Y-Bus
 LDC2NY Place 2^n on Y-Bus

Bit Oriented:

SETNR Set RAM, Bit n
 SETNA Set ACC, Bit n
 SETND Set D, Bit n
 SONCZ Set OVR, N, C, Z, in Status Register
 SL Set LINK Bit in Status Register
 SF1 Set Flag1 Bit in Status Register
 SF2 Set Flag2 Bit in Status Register
 SF3 Set Flag3 Bit in Status Register
 RSTNR Reset RAM, Bit n
 RSTNA Reset ACC, Bit n
 RSTND Reset D, Bit n
 RONCZ Reset OVR, N, C, Z, in Status Register
 RL Reset LINK Bit in Status Register
 RF1 Reset Flag1 Bit in Status Register
 RF2 Reset Flag2 Bit in Status Register
 RF3 Reset Flag3 Bit in Status Register
 TSTNR Test RAM, Bit n
 TSTNA Test ACC, Bit n
 TSTND Test D, Bit n

Arithmetic Operations:

MOVE Move and Update Status
 COMP Complement (1's Complement)
 INC Increment
 NEG Two's Complement

Conditional Test:

TNOZ Test $(N \oplus OVR) + Z$
 TNO Test $N \oplus OVR$
 TZ Test Zero Bit
 TOVR Test Overflow Bit
 TLOW Test for LOW
 TC Test Carry Bit
 TZC Test $Z + \bar{C}$
 TN Test Negative Bit
 TL Test LINK Bit
 TF1 Test Flag1 Bit
 TF2 Test Flag2 Bit
 TF3 Test Flag3 Bit

APPLICATIONS

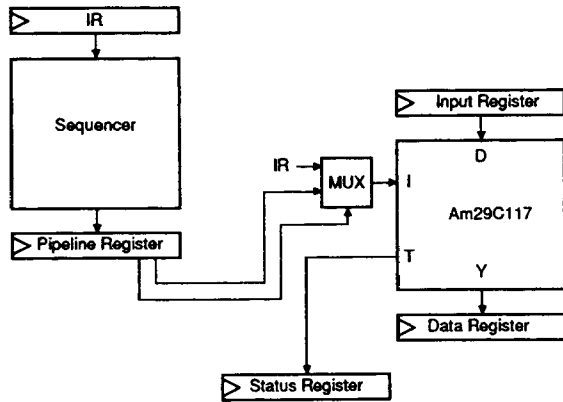

076988-004A

BD008220

Figure 13. System Block Diagram

DATA PATH TIMING ANALYSIS

I. Without any External Logic

		29C117	29C117-1	29C117-2
Pipeline Register	CP-Q	9	9	9
RALU (29C117)	I-T	105	60	49
Status Register	D-CP	4	4	4
	Total:	118	73	62
Pipeline Register	CP-Q	9	9	9
RALU (29C117)	I-Y	98	60	49
Data Register	D-CP	4	4	4
	Total:	111	73	62
Input Register	CP-Q	9	9	9
RALU (29C117)	D-Y	78	49	40
Data Register	D-CP	4	4	4
	Total:	91	62	53

II. With Multiplexers for Two Address

		29C117	29C117-1	29C117-2
Pipeline Register	CP-Q	9	9	9
Multiplexer	Sel-Y	5	5	5
RALU (29C117)	I-T	105	60	49
Status Register	D-CP	4	4	4
	Total:	123	78	67
Pipeline Register	CP-Q	9	9	9
Multiplexer	Sel-Y	5	5	5
RALU (29C117)	I-Y	98	60	49
Data Register	D-CP	4	4	4
	Total:	116	78	67

ABSOLUTE MAXIMUM RATINGS

Storage Temperature	-65 to +150°C
(Case) Temperature Under Bias	-55 to +125°C
Supply Voltage to	
Ground Potential Continuous	-0.3 to +7.0 V
DC Voltage Applied to Outputs For	
High Output State	-0.3 to +V _{CC} + 0.3 V
DC Input Voltage	-0.3 to +V _{CC} + 0.3 V
DC Output Current, Into LOW Outputs	30 mA
DC Input Current	-10 to +10 mA

Stresses above those listed under ABSOLUTE MAXIMUM RATINGS may cause permanent device failure. Functionality at or above these limits is not implied. Exposure to absolute maximum ratings for extended periods may affect device reliability.

OPERATING RANGES

Commercial (C) Devices

DC CHARACTERISTICS over operating range unless otherwise specified (for APL Products, Group A, Subgroups 1, 2, 3, are tested unless otherwise noted)

Ambient Temperature (T_A) 0 to +70°C
 Supply Voltage (V_{CC}) +4.5 to +5.5 V

Military* (M) Devices

Ambient Temperature (T_A) -55 to +125°C
 Supply Voltage (V_{CC}) +4.5 to +5.5 V

*Military Products 100% tested at T_A = +25°C, +125°C, and -55°C

Operating ranges define those limits between which the functionality of the device is guaranteed.

Thermal Resistance and I/O Capacitance (Typical)

Symbol	PL 068	CG 068	CL 068	Units
θ _{JA}	35	25	37	°C/W
C*	5	5	10	pF/Pin

*Tested on a sample basis only.

Parameter Symbol	Parameter Description	Test Conditions (Note 1)		Min.	Max.	Unit
V _{OH}	Output HIGH Voltage	V _{CC} = Min., V _{IN} = V _{IH} or V _{IL}	COM'L I _{OH} = -1.6 mA	2.4		V
			MIL I _{OH} = -1.2 mA			
V _{OL}	Output LOW Voltage	V _{CC} = Min., V _{IN} = V _{IH} or V _{IL}	COM'L I _{OL} = 16 mA		0.5	V
			MIL I _{OL} = 12 mA			
V _{IH}	Guaranteed Input Logical HIGH Voltage (Note 2)			2.0		V
V _{IL}	Guaranteed Input Logical LOW Voltage (Note 2)				0.8	V
I _{IL}	Input LOW Current	V _{CC} = Max., V _{IN} = 0.5 V			-10	μA
I _{IH}	Input HIGH Current	V _{CC} = Max., V _{IN} = V _{CC} - 0.5 V			10	μA
I _{OZH}	Off-State (High Impedance) Output Current	V _{CC} = Max., V _O = 2.4 V			10	μA
I _{OZL}	Off-State (High Impedance) Output Current	V _{CC} = Max., V _O = 0.5 V			-10	μA
I _{CC}	Static Power Supply Current (Note 3)	V _{CC} = Max. (Note 4) I _O = 0 μA	COM'L T _A = 0 to +70°C	CMOS V _{IN} = V _{CC} or GND	120	mA
				TTL V _{IN} = 0.5 or 2.4 V	170	
			MIL T _A = -55 to +125°C	CMOS V _{IN} = V _{CC} or GND	150	
				TTL V _{IN} = 0.5 or 2.4 V	200	
C _{PD}	Power Dissipation Capacitance (Note 4)	V _{CC} = 5.0 V, T _A = 25°C, No Load			850 pF Typical	

- Notes: 1. V_{CC} conditions shown as Min. or Max. refer to the (±10%) V_{CC} limits.
 2. These input levels provide zero-noise immunity and should only be statically tested in a noise-free environment (not functionally tested).
 3. Worst-case I_{CC} is measured at the lowest temperature in the specified operating range.
 4. Use CMOS I_{CC} when the device is driven by CMOS circuits, and TTL I_{CC} when the device is driven by TTL circuits.
 5. C_{PD} determines the no-load dynamic current consumption:

$$I_{CC}(\text{Total}) = I_{CC}(\text{Static}) (C_{PD} + n C_L) \frac{1}{2}$$
 where f is the clock frequency, C_L is the output load capacitance, and n is the number of loads.

Am29C117 I_{CC} vs Cycle Time

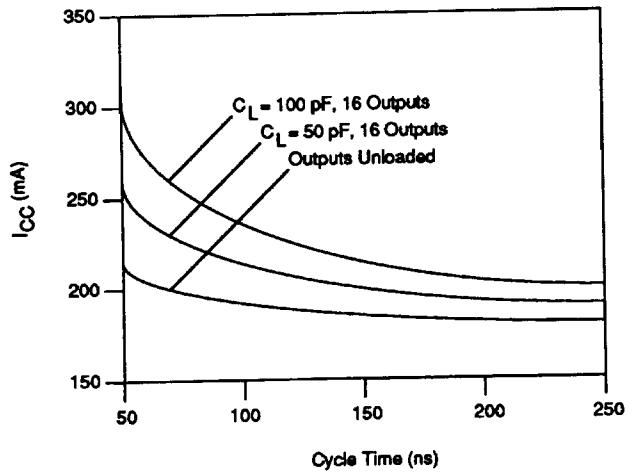

078008-003A

OP002750

Note: Values are calculated as typical I_{CC} at $V_{CC} = 5.5$ V.

SWITCHING CHARACTERISTICS over COMMERCIAL operating range

($T_A = 0$ to $+70^\circ\text{C}$, $V_{CC} = 4.50$ to 5.50 V, $C_L = 50$ pF)

Am29C117

A. Combinational Delays (nsec)

		Outputs		
		Y ₀₋₁₅	T ₁₋₄	CT
Input	I ₀₋₄ (ADDR)	98	105	-
	I ₀₋₁₅ (DATA)	98	105	-
	I ₀₋₁₅ (INSTR)	98	105	58
	DLE	73	75	-
	T ₁₋₄	-	-	46
	CP	76	83	48
	D ₀₋₁₅	78	80	-
	IEN	-	-	53

B. Enable/Disable Times (nsec) ($C_L = 5$ pF for disable only)

From Input	To Output	Enable		Disable	
		t _{PZH}	t _{PZL}	t _{PHZ}	t _{PLZ}
OE _v	Y ₀₋₁₅	25	25	25	25
OE _T	T ₁₋₄	25	25	25	25

C. Clock and Pulse Requirements (nsec)

Input	Min. LOW Time	Min. HIGH Time
CP	21	30
DLE	-	15
IEN	22	-

D. Setup and Hold Times (nsec)

Input	With Respect to	HIGH-to-LOW Transition		LOW-to-HIGH Transition		Comment			
		Setup	Hold	Setup	Hold				
I ₀₋₄ (RAM ADDR)	CP	(t _{s1}) 24	(t _{h1}) 0	-	-	Single ADDR (Source)			
I ₀₋₄ (RAM ADDR)	CP and IEN both LOW	(t _{s2}) 10	-	-	(t _{h7}) 2	Two ADDR (Destination)			
I ₀₋₁₅ (DATA)	CP	-	-	(t _{s8}) 78	(t _{h8}) 0				
I ₀₋₁₅ (INSTR)	CP	(t _{s3}) 38 †	(t _{h3}) 17 †	(t _{s9}) 78	(t _{h9}) 2				
I ₀₋₁₅ (INSTR)	IEN	(t _{s16}) 6	(t _{h16}) 18	-	-	Two ADDR (Immediate)			
IEN HIGH	CP	(t _{s4}) 10	-	-	(t _{h10}) 0	Disable			
IEN LOW	CP	-	-	(t _{s11}) 22	(t _{s5}) 20	(t _{h11}) 0	(t _{h5}) 0	Enable	Immediate first cycle
SRE	CP	-	-	(t _{s12}) 17	(t _{h12}) 0				
D	CP	-	-	(t _{s13}) 53	(t _{h13}) 0				
D	DLE	(t _{s6}) 10	(t _{h6}) 6	-	-				
DLE	CP	-	-	(t _{s14}) 54	(t _{h14}) 0				

†Timing for immediate instruction for first cycle.

SWITCHING CHARACTERISTICS over COMMERCIAL operating range (Cont'd.)

Am29C117-1

A. Combinational Delays (nsec)

Input	Outputs		
	Y ₀₋₁₅	T ₁₋₄	CT
I ₀₋₄ (ADDR)	60	60	-
I ₀₋₁₅ (DATA)	60	60	-
I ₀₋₁₅ (INSTR)	60	60	27
DLE	48	47	-
T ₁₋₄	-	-	24
CP	53	57	31
D ₀₋₁₅	49	46	-
IEN	-	-	24

B. Enable/Disable Times (nsec)
(C_L = 5 pF for disable only)

From Input	To Output	Enable		Disable	
		t _{PZH}	t _{PZL}	t _{PHZ}	t _{PLZ}
OE _Y	Y ₀₋₁₅	21	21	21	21
OE _T	T ₁₋₄	21	21	21	21

C. Clock and Pulse Requirements (nsec)

Input	Min. LOW Time	Min. HIGH Time
CP	21	15
DLE	-	15
IEN	15	-

D. Setup and Hold Times (nsec)

Input	With Respect to	HIGH-to-LOW Transition		LOW-to-HIGH Transition		Comment			
		Setup	Hold	Setup	Hold				
I ₀₋₄ (RAM ADDR)	CP	(t _{s1}) 11	(t _{h1}) 0	-	-	Single ADDR (Source)			
I ₀₋₄ (RAM ADDR)	CP and IEN both LOW	(t _{s2}) 2	-	-	(t _{h7}) 0	Two ADDR (Destination)			
I ₀₋₁₅ (DATA)	CP	-	-	(t _{s8}) 69	(t _{h8}) 0				
I ₀₋₁₅ (INSTR)	CP	(t _{s3}) 19 †	(t _{h3}) 12 †	(t _{s9}) 69	(t _{h9}) 0				
I ₀₋₁₅ (INSTR)	IEN	(t _{s16}) 6	(t _{h16}) 18	-	-	Two ADDR (Immediate)			
IEN HIGH	CP	(t _{s4}) 5	-	-	(t _{h10}) 0	Disable			
IEN LOW	CP	-	-	(t _{s11}) 12	(t _{s5}) 6	(t _{h11}) 0	(t _{h5}) 0	Enable	Immediate first cycle
SRE	CP	-	-	(t _{s12}) 11	-	(t _{h12}) 0			
D	CP	-	-	(t _{s13}) 39	-	(t _{h13}) 0			
D	DLE	(t _{s6}) 5	(t _{h6}) 3	-	-	-	-		
DLE	CP	-	-	(t _{s14}) 42	-	(t _{h14}) 0			

†Timing for immediate instruction for first cycle.

SWITCHING CHARACTERISTICS over COMMERCIAL operating range (Cont'd.)

Am29C117-2

A. Combinational Delays (nsec)

Input	Outputs		
	Y ₀₋₁₅	T ₁₋₄	CT
I ₀₋₄ (ADDR)	49	49	-
I ₀₋₁₅ (DATA)	49	49	-
I ₀₋₁₅ (INSTR)	49	49	22
DLE	40	39	-
T ₁₋₄	-	-	22
CP	45	45	26
D ₀₋₁₅	40	38	-
IEN	-	-	22

B. Enable/Disable Times (nsec)
(C_L = 5 pF for disable only)

From Input	To Output	Enable		Disable	
		tpZH	tpZL	tpHZ	tpLZ
OE _Y	Y ₀₋₁₅	19	19	19	19
OE _T	T ₁₋₄	19	19	19	19

C. Clock and Pulse Requirements (nsec)

Input	Min. LOW Time	Min. HIGH Time
CP	20	15
DLE	-	15
IEN	15	-

D. Setup and Hold Times (nsec)

Input	With Respect to	HIGH-to-LOW Transition		LOW-to-HIGH Transition		Comment			
		Setup	Hold	Setup	Hold				
I ₀₋₄ (RAM ADDR)	CP	(t _{s1}) 10	(t _{h1}) 0	-	-	Single ADDR (Source)			
I ₀₋₄ (RAM ADDR)	CP and IEN both LOW	(t _{s2}) 2	-	-	(t _{h7}) 0	Two ADDR (Destination)			
I ₀₋₁₅ (DATA)	CP	-	-	(t _{s8}) 61	(t _{h8}) 0				
I ₀₋₁₅ (INSTR)	CP	(t _{s3}) 17 †	(t _{h3}) 10 †	(t _{s9}) 61	(t _{h9}) 0				
I ₀₋₁₅ (INSTR)	IEN	(t _{s16}) 6	(t _{h16}) 18	-	-	Two ADDR (Immediate)			
IEN HIGH	CP	(t _{s4}) 5	-	-	(t _{h10}) 0	Disable			
IEN LOW	CP	-	-	(t _{s11}) 11	(t _{s5}) 6	(t _{h11}) 0	(t _{h5}) 0	Enable	Immediate first cycle
SRE	CP	-	-	(t _{s12}) 10	(t _{h12}) 0				
D	CP	-	-	(t _{s13}) 34	(t _{h13}) 0				
D	DLE	(t _{s6}) 5	(t _{h6}) 3	-	-				
DLE	CP	-	-	(t _{s14}) 36	(t _{h14}) 0				

†Timing for immediate instruction for first cycle.

SWITCHING CHARACTERISTICS over **MILITARY** operating range (for APL Products, Group A, Subgroups 9, 10, 11 are tested unless otherwise noted)

Am29C117-1

A. Combinational Delays (nsec)

Input	Outputs		
	Y ₀₋₁₅	T ₁₋₄	CT
I ₀₋₄ (ADDR)	65	64	-
I ₀₋₁₅ (DATA)	65	64	-
I ₀₋₁₅ (INSTR)	65	64	27
DLE	53	52	-
T ₁₋₄	-	-	27
CP	58	61	34
D ₀₋₁₅	53	50	-
IEN	-	-	26

B. Enable/Disable Times (nsec)
(C_L = 5 pF for disable only)

From Input	To Output	Enable		Disable	
		t _{pZH}	t _{pZL}	t _{pHZ}	t _{pLZ}
OE _Y	Y ₀₋₁₅	22	22	22	22
OE _T	T ₁₋₄	22	22	22	22

C. Clock and Pulse Requirements (nsec)

Input	Min. LOW Time	Min. HIGH Time
CP	22	15
DLE	-	15
IEN	15	-





D. Setup and Hold Times (nsec)

Input	With Respect to	HIGH-to-LOW Transition		LOW-to-HIGH Transition		Comment		
		Setup	Hold	Setup	Hold			
I ₀₋₄ (RAM ADDR)	CP	(t _{s1}) 12	(t _{h1}) 1	-	-	Single ADDR (Source)		
I ₀₋₄ (RAM ADDR)	CP and IEN both LOW	(t _{s2}) 2	-	-	(t _{h7}) 0	Two ADDR (Destination)		
I ₀₋₁₅ (DATA)	CP	-	-	(t _{s8}) 72	(t _{h8}) 0			
I ₀₋₁₅ (INSTR)	CP	(t _{s3}) 21 †	(t _{h3}) 12 †	(t _{s9}) 72	(t _{h9}) 0			
I ₀₋₁₅ (INSTR)	IEN	(t _{s16}) 6	(t _{h16}) 18	-	-	Two ADDR (Immediate)		
IEN HIGH	CP	(t _{s4}) 5	-	-	(t _{h10}) 0	Disable		
IEN LOW	CP	-	-	(t _{s11}) 13	(t _{s5}) 7	(t _{h11}) 0	(t _{h5}) 0	Enable
SRE	CP	-	-	(t _{s12}) 11	(t _{h12}) 1			
D	CP	-	-	(t _{s13}) 44	(t _{h13}) 0			
D	DLE	(t _{s6}) 6	(t _{h6}) 4	-	-			
DLE	CP	-	-	(t _{s14}) 47	(t _{h14}) 0			

†Timing for immediate instruction for first cycle.

SWITCHING WAVEFORMS

KEY TO SWITCHING WAVEFORMS

WAVEFORM	INPUTS	OUTPUTS
	MUST BE STEADY	WILL BE STEADY
	MAY CHANGE FROM H TO L	WILL BE CHANGING FROM H TO L
	MAY CHANGE FROM L TO H	WILL BE CHANGING FROM L TO H
	DON'T CARE; ANY CHANGE PERMITTED	CHANGING; STATE UNKNOWN
	DOES NOT APPLY	CENTER LINE IS HIGH IMPEDANCE "OFF" STATE

KS000010

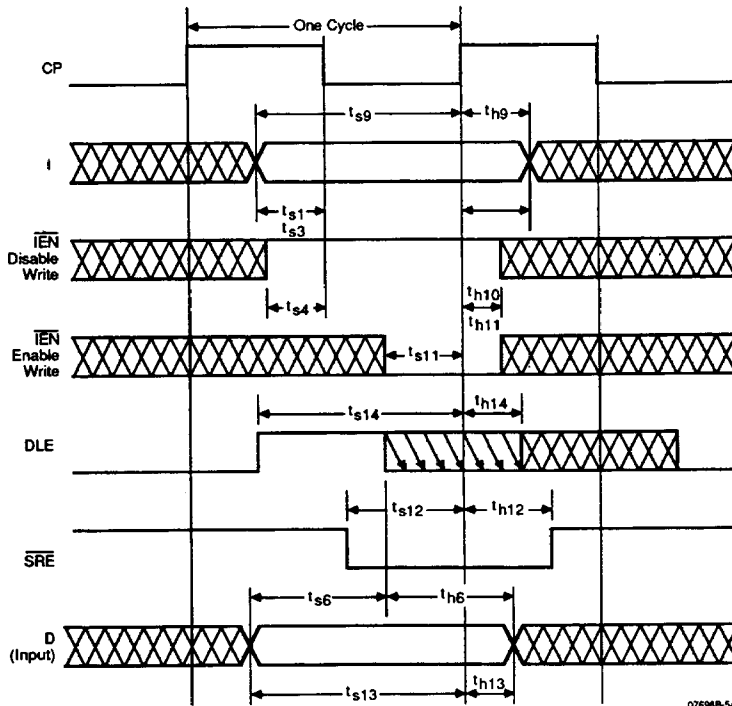

07698B-5A

WF025870

Single-Address Access Timing

If t_{h6} is satisfied, t_{h13} need not be satisfied.

SWITCHING WAVEFORMS (Cont'd)

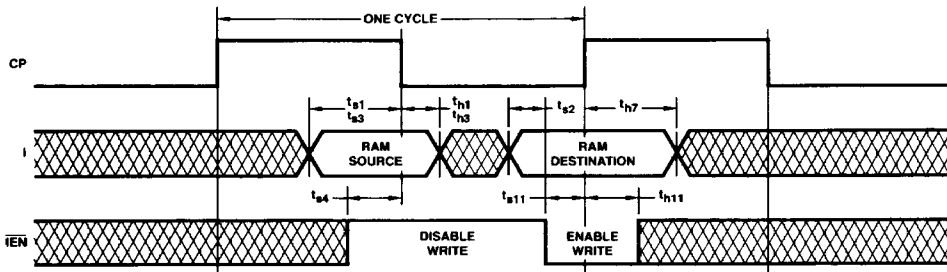

WF002546

Double-Address Access Timing

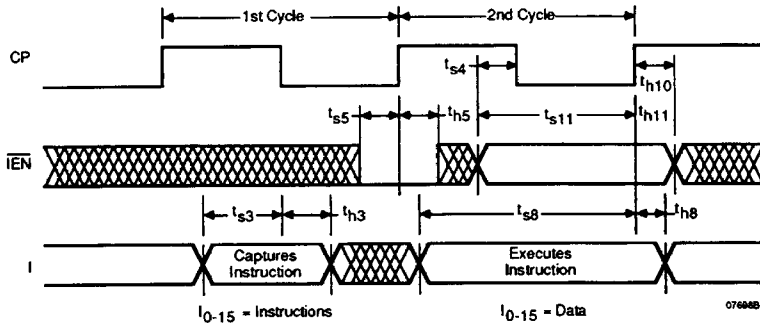

076988-003A

WF025900

One-Address Immediate Instruction Cycle Timing

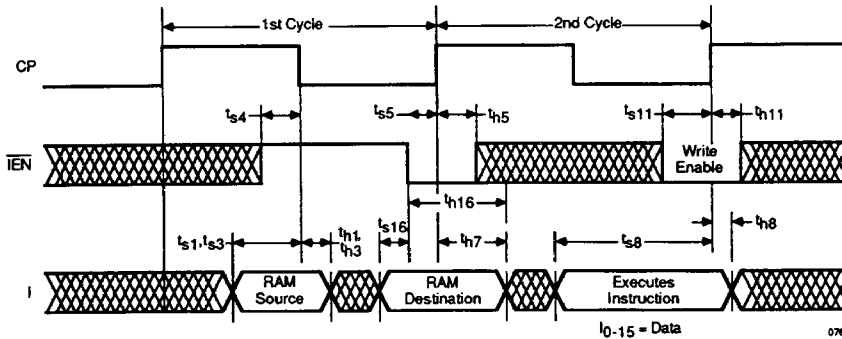

076988-004A

WF025890

Two-Address Immediate Instruction Timing

Test Philosophy and Methods

The following points give the general philosophy which we apply to tests that must be properly engineered if they are to be implemented in an automatic environment. The specifics of what philosophies applied to which test are shown in the data sheet.

1. Ensure the part is adequately decoupled at the test head. Large changes in V_{CC} current when the device switches may cause function failures due to V_{CC} changes.
2. Do not leave inputs floating during any tests, as they may start to oscillate at high frequency.
3. Do not attempt to perform threshold tests at high speed. Following an input transition, ground current may change by as much as 400 mA in 5-8 ns. Inductance in the ground cable may allow the ground pin at the device to rise by hundreds of millivolts momentarily.
4. Use extreme care in defining input levels for AC tests. Many inputs may be changed at once, so there will be significant noise at the device pins which may not actually reach V_{IL} or V_{IH} until the noise has settled. AMD recommends using $V_{IL} \leq 0$ V and $V_{IH} \geq 3.0$ V for AC tests.
5. To simplify failure analysis, programs should be designed to perform DC, Function, and AC tests as three distinct groups of tests.

6. Capacitive Loading for AC Testing

Automatic testers and their associated hardware have stray capacitance that varies from one type of tester to another, but is generally around 50 pF. This makes it impossible to make direct measurements of parameters that call for a smaller capacitive load than the associated stray capacitance. Typical examples of this are the so-called "float delays," which measure the propagation delays into the high-impedance state and are usually specified at a load capacitance of 5.0 pF. In these cases, the test is performed at the higher load capacitance (typically 50 pF), and engineering correlations based on data taken with a bench setup are used to predict the result at the lower capacitance.

Similarly, a product may be specified at more than one capacitive load. Since the typical automatic tester is not capable of switching loads in mid-test, it is impossible to make measurements at both capacitances even though they may both be greater than the stray capacitance. In these cases, a measurement is made at one of the two capacitances. The result at the other capacitance is predicted from engineering correlations based on data taken with a bench setup and the knowledge that certain DC measurements (I_{OH} , I_{OL} , for example) have already been taken and are within specification. In some cases, special DC tests are performed in order to facilitate this correlation.

7. Threshold Testing

the noise associated with automatic testing (due to the long, inductive cables) and the high gain of the tested device when in the vicinity of the actual device threshold, frequently give rise to oscillations when testing high-speed circuits. These oscillations are not indicative of a reject device, but instead, of an overtaxed test system. To minimize this problem, thresholds are tested at least once for each input pin. Thereafter, "hard" HIGH and LOW levels are used for other tests. Generally this means that function and AC testing are performed at "hard" input levels rather than at V_{IL} Max. and V_{IH} Min.

8. AC Testing

Occasionally parameters are specified that cannot be measured directly on automatic testers because of tester limitations. Data input hold times often fall into this category. In these cases, the parameter in question is guaranteed by correlating these tests with other AC tests that have been performed. These correlations are arrived at by the cognizant engineer using data from precise bench measurements in conjunction with the knowledge that certain DC parameters have already been measured and are within specification.

In some cases, certain AC tests are redundant since they can be shown to be predicted by other tests that have already been performed. In these cases, the redundant tests are not performed.

SWITCHING TEST CIRCUITS

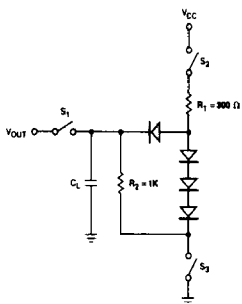

TCR01331

A. Three-State Outputs

$$R_1 = 300 \Omega$$

- Notes:
1. $C_L = 50$ pF includes scope probe, wiring and stray capacitances without device in test fixture.
 2. S_1 , S_2 , S_3 are closed during function tests and all AC tests except output enable tests.
 3. S_1 and S_3 are closed while S_2 is open for t_{pZH} test.
 S_1 and S_2 are closed while S_3 is open for t_{pZL} test.
 4. $C_L = 5.0$ pF for output disable tests.

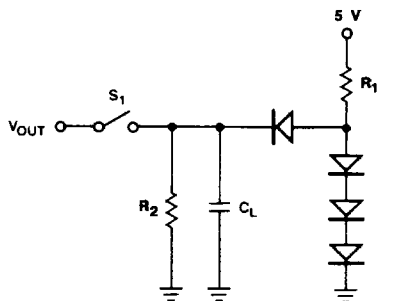

TCR01341

B. Normal Outputs

$$R_1 = 300 \Omega$$

$$R_2 = 3.0 \text{ k}\Omega$$

SWITCHING TEST WAVEFORMS

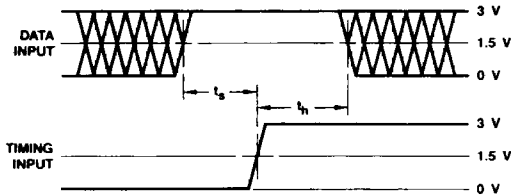

WFR02970

- Notes: 1. Diagram shown for HIGH data only. Output transition may be opposite sense.
 2. Cross hatched area is don't care condition.

A. Set-up, Hold, and Release Times

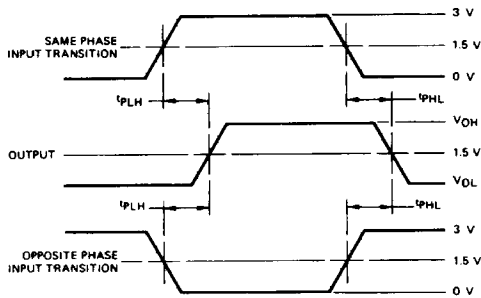

WFR02980

C. Propagation Delay

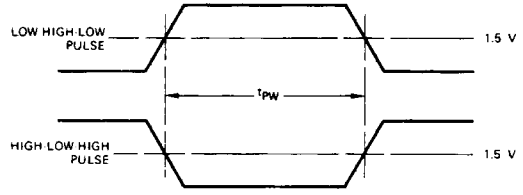

WFR02790

B. Pulse Width

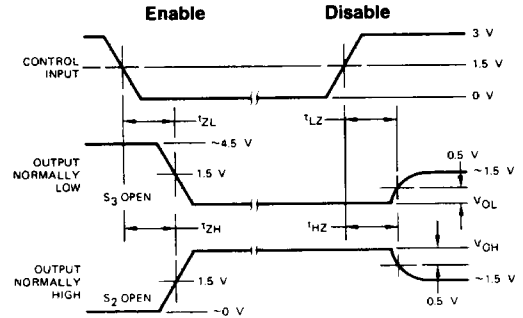

WFR02660

- Notes: 1. Diagram shown for Input Control Enable-LOW and Input Control Disable-HIGH.
 2. S₁, S₂ and S₃ of Load Circuit are closed except where shown.

D. Enable and Disable Times

INPUT/OUTPUT CIRCUIT DIAGRAMS

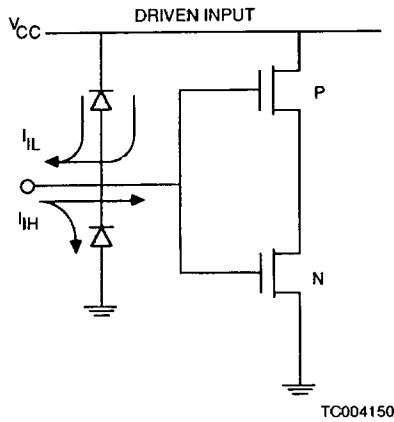

TC004150

$C_i \approx 5.0$ pF, all inputs

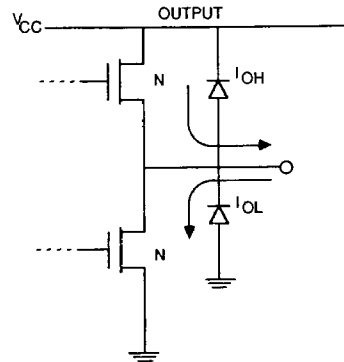

TC004160

$C_o \approx 5.0$ pF, all outputs

PHYSICAL DIMENSIONS*

CG 068

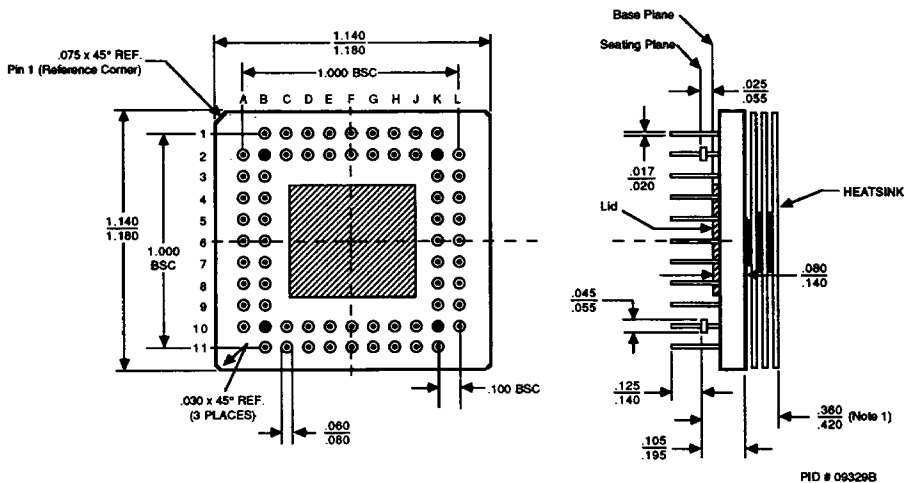

Note: 1. This dimension refers to a heatsink with only 3 fins. For heatsinks with more than 3 fins, the following dimensions apply: 4 fins = .450/.510
6 fins = .540/.600
7 fins = .690/.750

PL 068

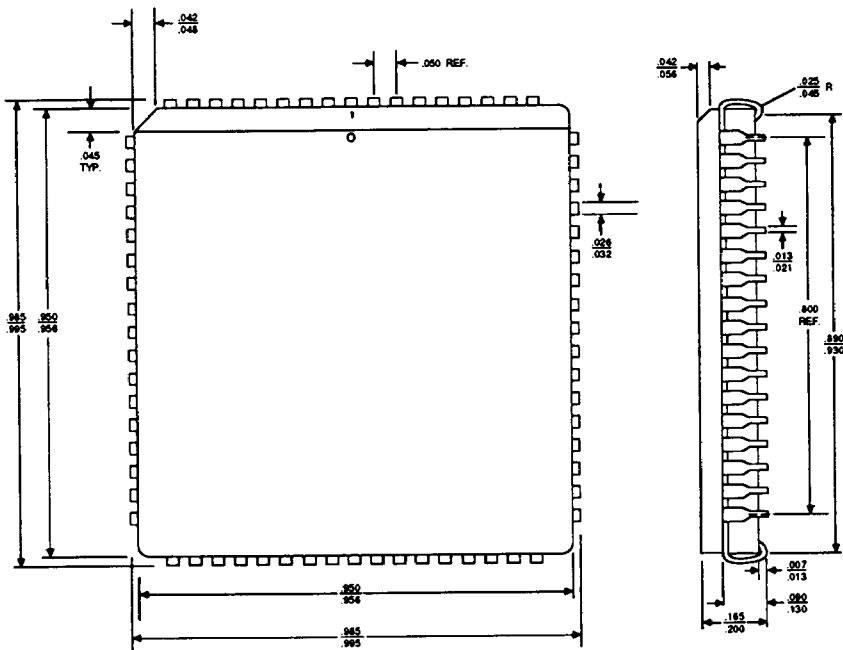

*For reference only. All measurements are in inches. BSC is the ANSI standard for Basic Space Centering.

PHYSICAL DIMENSIONS (Cont'd.)

CL 068

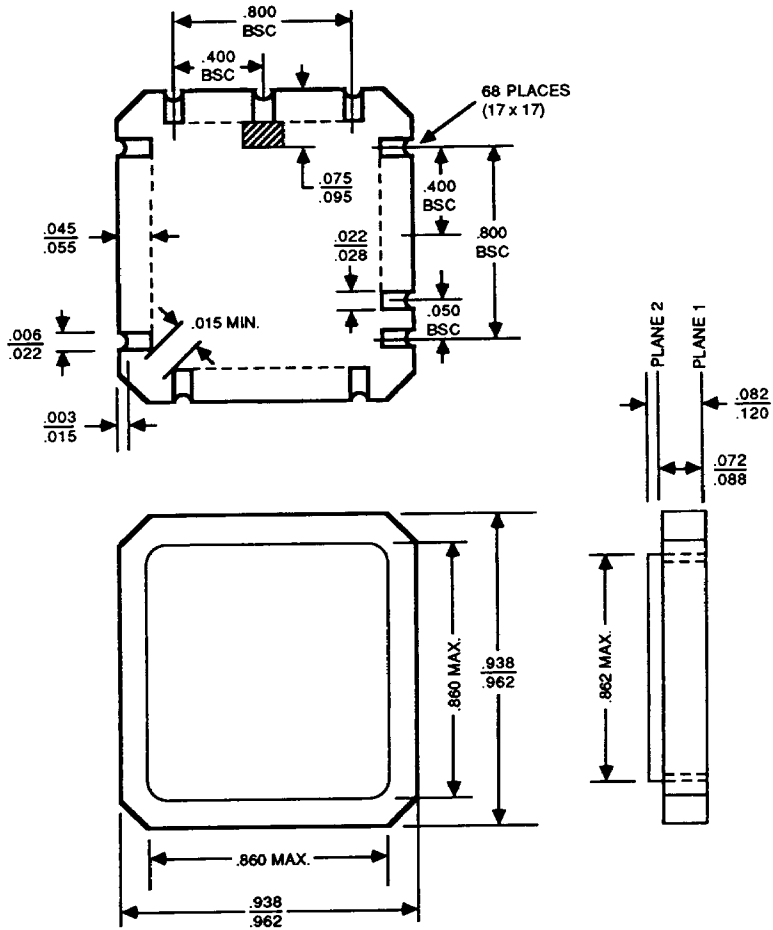

PID# 07877B

North American

ALABAMA	(205) 882-9122
ARIZONA	(602) 242-4400
CALIFORNIA	
Culver City	(213) 645-1524
Newport Beach	(714) 752-6262
San Diego	(619) 560-7030
San Jose	(408) 452-0500
Woodland Hills	(818) 992-4155
CANADA, Ontario	
Kanata	(613) 592-0060
Willowdale	(416) 224-5193
COLORADO	(303) 741-2900
CONNECTICUT	(203) 264-7800
FLORIDA	
Clearwater	(813) 530-9971
Ft. Lauderdale	(305) 776-2001
Orlando	(407) 830-8100
GEORGIA	(404) 449-7920
ILLINOIS	
Chicago	(312) 773-4422
Naperville	(312) 505-9517
INDIANA	(317) 244-7207
KANSAS	(913) 451-3115
MARYLAND	(301) 796-9310
MASSACHUSETTS	(617) 273-3970
MINNESOTA	(612) 938-0001
MISSOURI	(913) 451-3115
NEW JERSEY	(201) 299-0002
NEW YORK	
Liverpool	(315) 457-5400
Poughkeepsie	(914) 471-8180
Woodbury	(516) 364-8020
NORTH CAROLINA	(919) 878-8111
OHIO	
Columbus	(614) 891-6455
Dayton	(513) 439-0470
OREGON	(503) 245-0080
PENNSYLVANIA	
Allentown	(215) 398-8006
Willow Grove	(609) 662-2900
SOUTH CAROLINA	(803) 772-6760
TEXAS	
Austin	(512) 346-7830
Dallas	(214) 934-9099
Houston	(713) 785-9001
WASHINGTON	(206) 455-3600
WISCONSIN	(414) 792-0590

International

BELGIUM, Bruxelles	TEL (02) 771-91-42
	FAX (02) 762-37-12
	TLX 61028
FRANCE, Paris	TEL (1) 49-75-10-10
	FAX (1) 49-75-10-13
	TLX 263282
WEST GERMANY, Hannover area	TEL (0511) 736085
	FAX (0511) 721254
	TLX 922850
München	TEL (089) 4114170
	FAX (089) 406490
	TLX 523883
Stuttgart	TEL (0711) 62 33 77
	FAX (0711) 625187
	TLX 721882
HONG KONG	TEL 852-5-8654525
	FAX 852-5-8654335
	TLX 67955AMDAPHX
ITALY, Milan	TEL (02) 3390541
	FAX (02) 3533241
	TLX 315286
JAPAN, Kanagawa	TEL 462-47-2911
	FAX 462-47-1729

International (Continued)

Tokyo	TEL (03) 345-8241
	FAX (03) 342-5196
	TLX J24064AMDTKOJ
Osaka	TEL 06-243-3250
	FAX 06-243-3253
KOREA, Seoul	TEL 82-2-784-7598
	FAX 82-2-784-8014
LATIN AMERICA, Ft. Lauderdale	TEL (305) 484-8600
	FAX (305) 485-9736
	TEL 5109554261 AMDFTL
NORWAY, Hovik	TEL (02) 537810
	FAX (02) 591959
	TLX 79079
SINGAPORE	TEL 65-2257544
	FAX 65-2246113
	TLX RS55650 MMI RS
SWEDEN, Stockholm	TEL (08) 733 03 50
	FAX (08) 733 22 85
	TLX 11602
TAIWAN	TEL 886-2-7122066
	FAX 886-2-7122017
UNITED KINGDOM, Manchester area	TEL (0925) 828008
	FAX (0925) 827693
	TLX 628524
London area	TEL (04862) 22121
	FAX (0483) 756196
	TLX 859103

North American Representatives

CANADA	
Burnaby, B.C.	
DAVETEK MARKETING	(604) 430-3680
Calgary, Alberta	
VITEL ELECTRONICS	(403) 278-5833
Kanata, Ontario	
VITEL ELECTRONICS	(613) 592-0090
Mississauga, Ontario	
VITEL ELECTRONICS	(416) 676-9720
Quebec	
VITEL ELECTRONICS	(514) 636-5951
IDAHO	
INTERMOUNTAIN TECH MKGT	(208) 888-6071
INDIANA	
ELECTRONIC MARKETING CONSULTANTS, INC	(317) 921-3452
IOWA	
LORENZ SALES	(319) 377-4666
KANSAS	
Merriam	
LORENZ SALES	(913) 384-6556
Wichita	
LORENZ SALES	(316) 721-0500
KENTUCKY	
ELECTRONIC MARKETING CONSULTANTS, INC	(317) 921-3452
MICHIGAN	
MIKE RAICK ASSOCIATES	(313) 644-5040
MISSOURI	
LORENZ SALES	(314) 997-4558
NEBRASKA	
LORENZ SALES	(402) 475-4660
NEW MEXICO	
THORSON DESERT STATES	(505) 293-8555
NEW YORK	
NYCOM, INC	(315) 437-8343
OHIO	
Centerville	
DOLFUSS ROOT & CO	(513) 433-6776
Columbus	
DOLFUSS ROOT & CO	(614) 885-4844
Strongsville	
DOLFUSS ROOT & CO	(216) 238-0300
PENNSYLVANIA	
DOLFUSS ROOT & CO	(412) 221-4420
UTAH	
R ² MARKETING	(801) 595-0631

Advanced Micro Devices reserves the right to make changes in its product without notice in order to improve design or performance characteristics. The performance characteristics listed in this document are guaranteed by specific tests, guard banding, design and other practices common to the industry. For specific testing details, contact your local AMD sales representative. The company assumes no responsibility for the use of any circuits described herein.



Advanced Micro Devices, Inc. 901 Thompson Place, P.O. Box 3453, Sunnyvale, CA 94088, USA
Tel: (408) 732-2400 • TWX: 910-339-9280 • TELEX: 34-6306 • TOLL FREE: (800) 538-8450
APPLICATIONS HOTLINE TOLL FREE: (800) 222-9323 • (408) 749-5703

© 1988 Advanced Micro Devices, Inc.

026728 ✓