

PART NUMBER	POSITION
1326034-[]	4
638392-[]	8
638393-[]	10
638394-[]	12
638397-[]	18

Figure 1

1. INTRODUCTION

0.64mm unsealed dual-row automotive plug connectors listed in Figure 1 accept Contacts 1326028-[] (gold plated) and 638551-[] (tin plated) and mate with printed circuit (pc) board mounted or free-hanging connectors. These instructions cover assembly (inserting the contacts into the housing and mating the connectors) and disassembly (unmating the connectors and extracting the contacts from the housing) procedures.

A flat blade screwdriver with a tip having a width between 1.2 and 1.4 mm is required for insertion and extraction of the contacts.

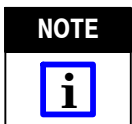

Dimensions in this instruction sheet are in metric units. Figures are not drawn to scale.

Reasons for reissue of this instruction sheet are provided in Section 6, REVISION SUMMARY.

2. DESCRIPTION

The plug connector features a housing with a connector locking latch, a TPA (or rear secondary) lock, and a CPA lock. Refer to Figure 1.

The housing contact cavities are polarized to prevent the contacts from being inserted upside-down. When

inserted into the housing, the contact deflects the housing retention finger, locking the contact into place. After all contacts are inserted, the TPA lock is used to ensure that the contacts are fully seated and to provide additional contact retention.

When mating connectors, the plug connector locking latch engages the locking tab of the mating connector and prevents separation. The CPA lock is used to ensure that the connectors are fully engaged and prevent accidental deflection of the locking latch.

The plug connector is shipped with the TPA lock and CPA lock in the pre-set (OPEN) position. Each lock is actuated when moved to the final-lock (CLOSED) position.

3. ASSEMBLY PROCEDURE

3.1. Inserting Contacts

The following procedure assumes that the contacts have been properly crimped. For detailed inspection requirements, refer to Application Specification 114-13006. Proceed as follows:

1. If the rear secondary lock of the plug connector is *not* in the OPEN position, move the rear secondary lock to the OPEN position (as described in Paragraph 4.2, Step 2).
2. Grasp the wire of the terminated contact approximately 19 mm behind the contact insulation barrel. Align the contact with the desired contact cavity at the wire end of the plug connector, orienting the contact so that the retention window is facing the straight edge of the contact cavity. See Figure 2. Push the contact straight into the contact cavity until it bottoms (there will be an audible “click”).

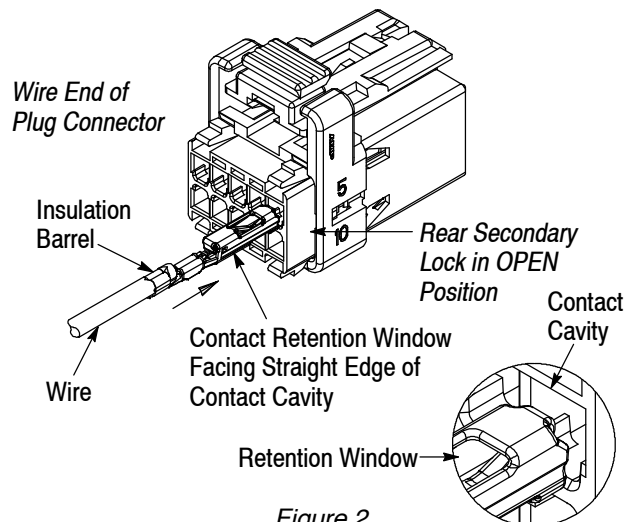

Figure 2



CAUTION DO NOT force the contact into the contact cavity. If there is resistance, pull the contact out, ensure proper orientation, and re-insert the contact.

3. Lightly pull back on the wire to ensure that the contact has engaged the housing retention finger.
4. After all contacts are inserted, push the rear secondary lock into the housing until the lock is in the CLOSED position. The rear secondary lock is in the CLOSED position when it is flush with the housing and the four latches engage the housing. Check to make sure that each latch is seated against the housing, and that there is no gap between the latch and the housing. See Figure 3.



NOTE If the rear secondary lock does not fully close, move the lock to the OPEN position, ensure that all contacts are fully seated, then try again. DO NOT force the rear secondary lock to close.

3.2. Mating Connectors

For board mounted applications, the following procedure assumes that the mating connector is properly installed onto the pc board.

Proceed as follows:

1. Align the connector locking latch of the plug connector with the locking tab of the mating connector. Refer to Figure 4, Detail A.
2. Push the plug connector into the mating connector, making sure that the key enters the keying slot, until the connector locking latch and locking tab engage (there will be an audible “click”). See Figure 4, Detail B.

Note: Mating Connector is Shown Board Mounted, Requirements Equally Apply to Free-Hanging Connector

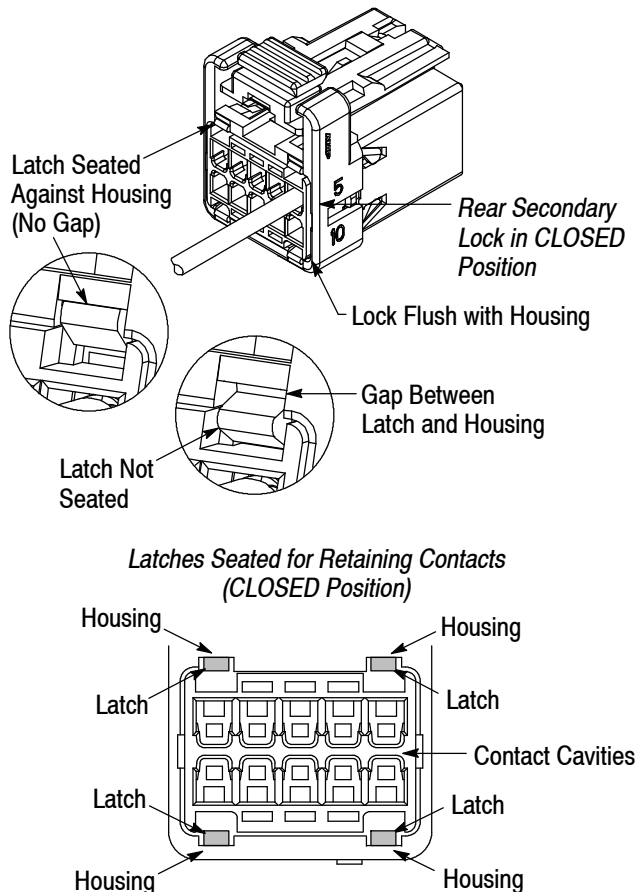

Figure 3

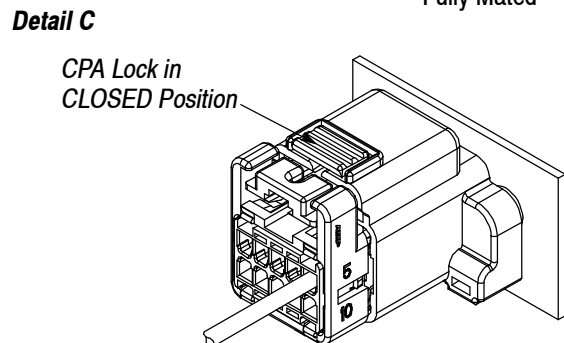
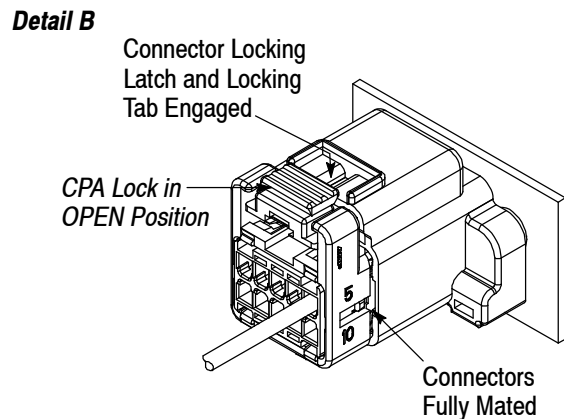
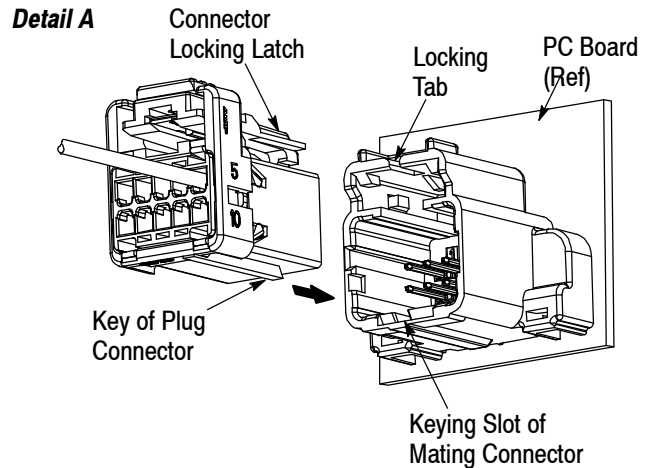

Figure 4

3. Slide the CPA lock of the plug connector toward the mating connector until it is in the CLOSED position. The lock is in the CLOSED position when it is completely over the mating connector. See Figure 4, Detail C.



CAUTION DO NOT force the CPA lock to close. The lock will not close unless the connectors are fully mated.

4. DISASSEMBLY

4.1. Unmating Connectors

1. Slide the CPA lock of the plug connector away from the mating connector until it is in the OPEN position. The CPA lock is in the OPEN position when it is no longer over the mating connector (as shown in Figure 4, Detail B).



CAUTION DO NOT force the CPA lock to open. It may be necessary to simultaneously push the plug connector toward the mating connector to relieve pressure on the lock while sliding the CPA lock to the OPEN position.

The CPA lock MUST be in the OPEN position before unmating the connectors.

2. Depress the connector locking latch of the plug connector, and pull the plug connector straight away from the mating connector.

4.2. Removing Contacts

1. Unmate the connectors (as described in Paragraph 4.1).

2. Insert the tip of the screwdriver between one of the four latches of rear secondary lock and the housing, and pivot the screwdriver away from the contact cavities until the latch is deflected. Repeat this step for the remaining three latches. See Figure 5. Check each latch to make sure that there is a gap between the latch and the housing. Check to make sure that all of the latches remained deflected.

3. From the mating face of the plug connector, insert the tip of the screwdriver behind the side latch in either side slot of the housing. See Figure 6, Detail A. Slide the side latch until it stops against the housing. Repeat this step for the side latch in the side slot at the opposite side of the housing. The rear secondary lock should be in the OPEN position (as shown in Figure 6, Detail B).

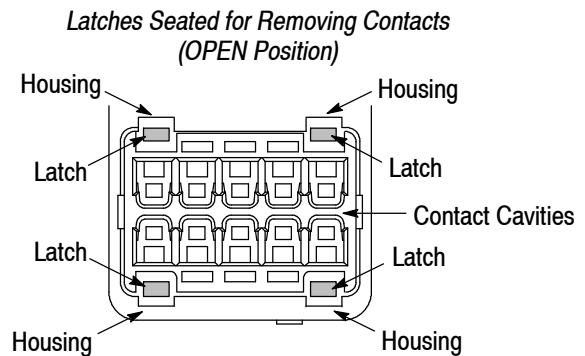
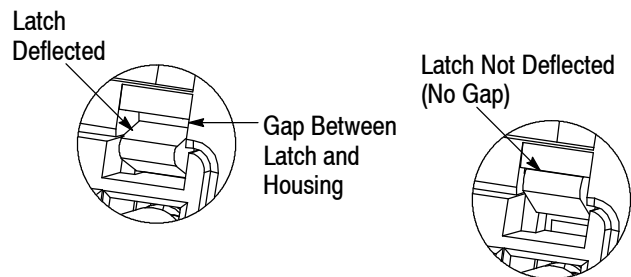
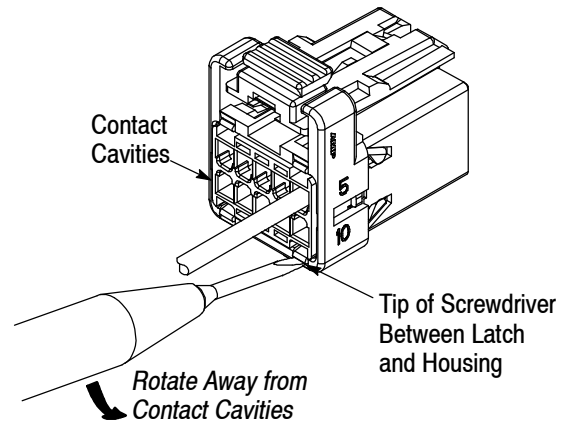
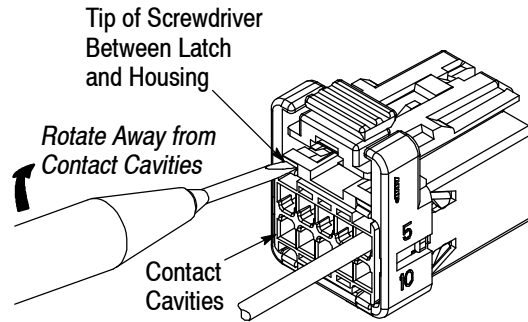
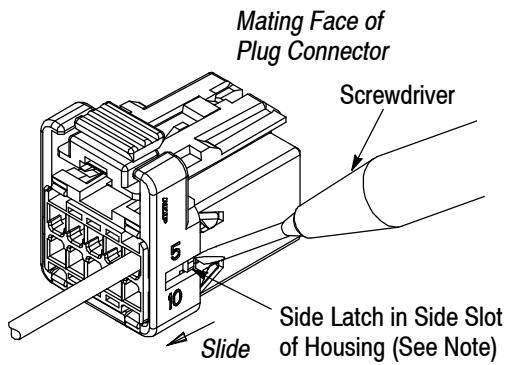
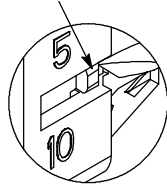

Figure 5

Detail A



Note: Applies to Both Sides of Housing



Detail B

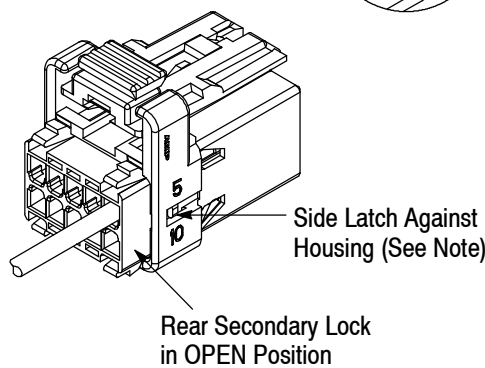
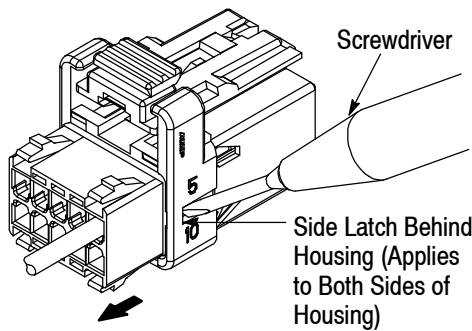

Figure 6

4. Push and slide the side latch until it is behind the housing and releases the rear secondary lock. Repeat this step for the side latch in the side slot at the opposite side of the housing. See Figure 7.
5. Pull the rear secondary lock straight out of, and slightly away from, the housing.



Pull Rear Secondary Lock Out of, and Slightly Away From, Housing

Figure 7

6. From the mating face of the plug connector, insert the tip of the screwdriver into the contact cavity of the contact to be removed. Refer to Figure 8.
7. Hold the screwdriver in place, and *gently* push the wire of the contact to be removed toward the housing until it stops (this will relieve the pressure on the contact retention window).
8. Pivot the screwdriver toward the other row of contact cavities to lift the housing retention finger away from the contact retention window. Refer to Figure 8. While holding the screwdriver in position, pull the wire until the contact is removed from the housing.

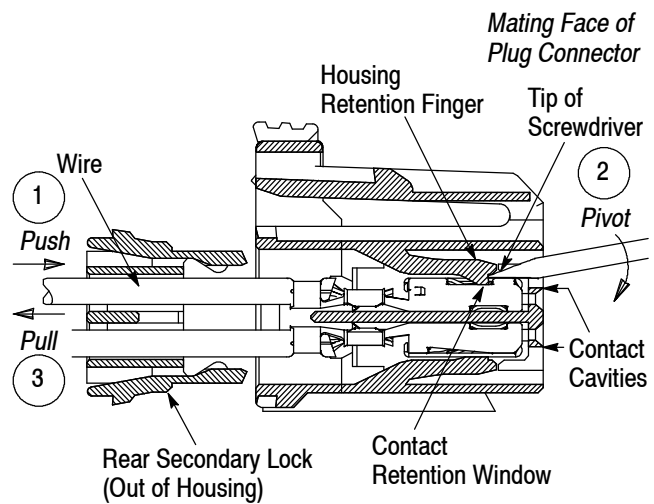

Figure 8

9. Pull the screwdriver out of the contact cavity.
10. Push the rear secondary lock back into the housing until it is in the CLOSED position as described in Paragraph 3.1, Step 4.

5. REPLACEMENT AND REPAIR

The contacts and housings are not repairable. Discard and replace any defective or damaged contacts or connectors. **DO NOT** re-use a terminated contact by removing the wire.

6. REVISION SUMMARY

Revisions to this instruction sheet include:

- Updated instruction sheet to corporate requirements