

Description

The ICS554-01A is a low skew clock buffer with a single complimentary PECL input to four PECL outputs. Part of IDT's Clock Blocks™ family, this is our lowest skew PECL clock buffer. The ICS554-01A is footprint compatible with the ICS554-01, but requires fewer passive components for termination thus providing a cost-saving alternative. For parts which do not require PECL inputs or outputs, see the ICS553 for a 1 to 4 low skew buffer, or the ICS552-02 for a 1 to 8 low skew buffer. For more than 8 outputs see the MK74CBxxx Buffalo™ series of clock drivers.

IDT makes many non-PLL and PLL based low skew output devices as well as Zero Delay Buffers to synchronize clocks. Contact us for all of your clocking needs.

Features

- Input frequency up to 200 MHz
- Advanced CMOS process
- Outputs are skew matched to within 50 ps
- Packaged in 16-pin TSSOP, Pb-free
- One PECL input to 4 PECL output clock drivers
- Operating Voltages of 3.3 V or 5 V
- Industrial temperature range
- Functional equivalent to ICS554-01
- Simplified passive termination network compared to ICS554-01

Block Diagram

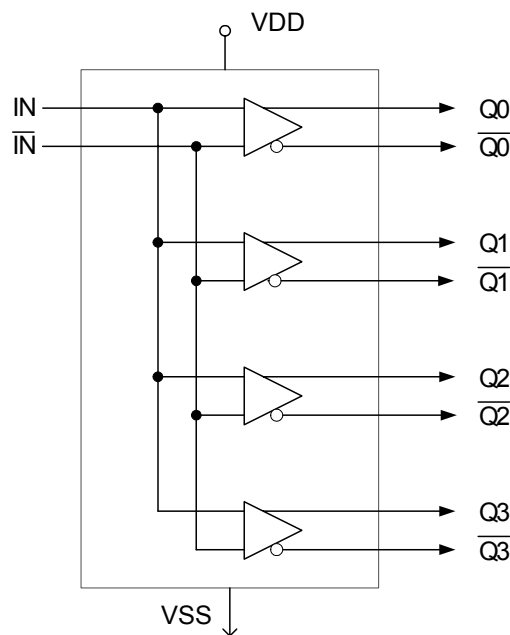

Pin Assignment

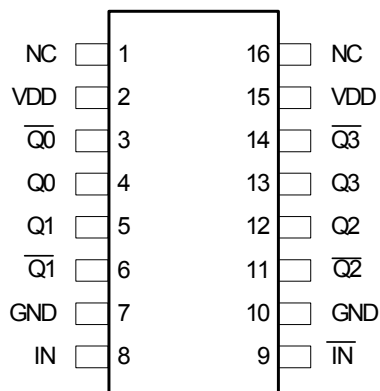

16-pin 173 mil (0.65mm) TSSOP

Pin Descriptions

Number	Name	Type	Pin Description
1	NC	—	No Connect.
2	VDD	Power	Connect to +3.3 V or 5 V. Must be same as pin 15.
3	$\overline{Q0}$	Output	Clock Output $\overline{Q0}$.
4	Q0	Output	Clock Output Q0.
5	Q1	Output	Clock Output Q1.
6	$\overline{Q1}$	Output	Clock Output $\overline{Q1}$.
7	GND	Power	Connect to Ground.
8	IN	Input	PECL Clock Input.
9	\overline{IN}	Input	Complementary PECL Clock Input.
10	GND	Power	Connect to Ground
11	$\overline{Q2}$	Output	Clock Output $\overline{Q2}$.
12	Q2	Output	Clock Output Q2.
13	Q3	Output	Clock Output Q3.
14	$\overline{Q3}$	Output	Clock Output $\overline{Q3}$.
15	VDD	Power	Connect to +3.3 V or 5 V. Must be same as pin 2.
16	NC	—	No Connect.

External Components

The ICS554-01A requires a decoupling capacitor of $0.01\mu\text{F}$ to be connected between VDD on pin 2 and GND on pin 7, as well as between VDD on pin 15 and GND on pin 10. These decoupling capacitors should be placed as close to the device as possible.

To achieve the low output skews that the ICS554-01A is capable of, careful attention must be paid to board layout. Essentially, all 8 outputs must have identical terminations, loads, and trace geometries. If they do not, the output skew will be degraded. For example, using a 30Ω series termination on one output (with 33Ω on the others) will cause at least 15ps of skew.

Termination for PECL or LVPECL Outputs

The clock layout topology shown below is a typical termination for PECL or LVPECL outputs. The two different layouts mentioned are recommended only as guidelines.

F_{OUT} and nF_{OUT} are low impedance follower outputs that generate PECL/LVPECL compatible outputs. Therefore, termination resistors (DC current path to ground) or current sources must be used for functionality. These outputs are designed to drive 50 ohm transmission lines. Matched impedance techniques should be used to maximize operating frequency and minimize signal distortion. There are a few simple termination schemes. The figures below show two different layouts which are recommended only as guidelines. Other suitable clock layouts may exist, but it is recommended that board designers simulate to guarantee compatibility across all printed circuit and clock component process variations.

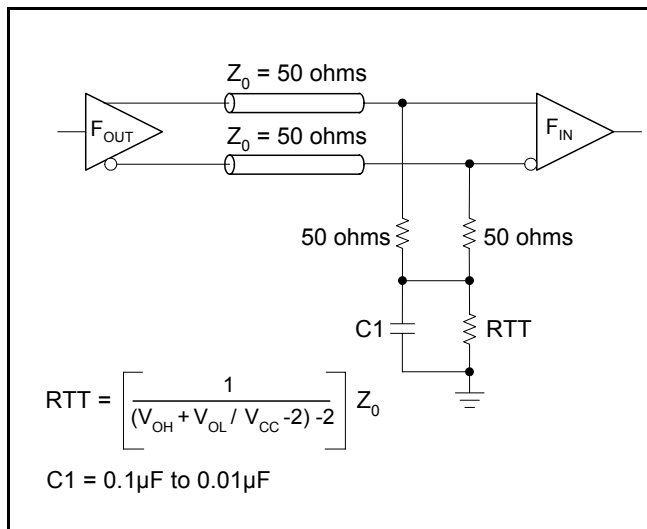

PECL or LVPECL Output Termination

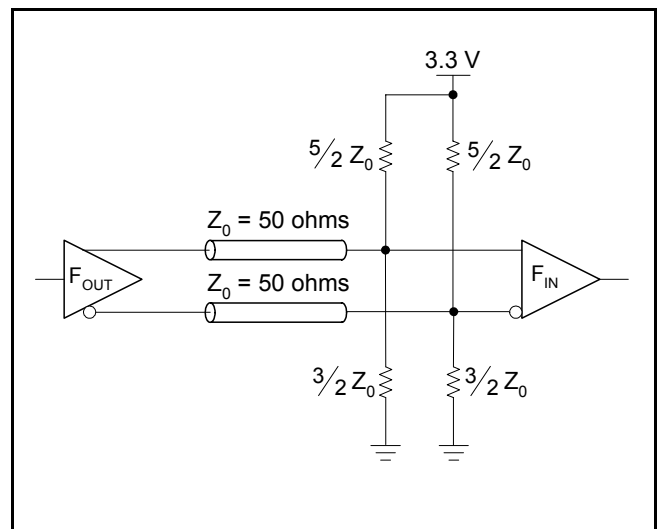

LVPECL Output Termination

Absolute Maximum Ratings

Stresses above the ratings listed below can cause permanent damage to the ICS554-01A. These ratings, which are standard values for IDT commercially rated parts, are stress ratings only. Functional operation of the device at these or any other conditions above those indicated in the operational sections of the specifications is not implied. Exposure to absolute maximum rating conditions for extended periods can affect product reliability. Electrical parameters are guaranteed only over the recommended operating temperature range.

Item	Rating
Supply Voltage, VDD	7 V
All Inputs and Outputs	-0.5 V to VDD+0.5 V
Ambient Operating Temperature	-40 to +85 °C
Storage Temperature	-65 to +150° C
Junction Temperature	125° C
Soldering Temperature	260° C

Recommended Operation Conditions

Parameter	Min.	Typ.	Max.	Units
Ambient Operating Temperature	-40	–	+85	°C
Power Supply Voltage (measured in respect to GND)	+3.15		+5.25	V

DC Electrical Characteristics

VDD=3.3 V ±5% Ambient temperature -40 to +85 °C

Parameter	Symbol	Conditions	Min.	Typ.	Max.	Units
Operating Voltage	VDD		3.15		5.25	V
Peak to Peak Input Voltage	IN		0.3		1.0	V
Input Common Mode Range	IN	VDD=3.3 V	VDD-2		VDD-0.6	
Input Common Mode Range	IN	VDD=5 V	VDD-3.7		VDD-0.6	
Output High Voltage	V _{OH}	Note 1	VDD-1.2			V
Output Low Voltage	V _{OL}	Note 1			VDD - 2.0	V
Operating Supply Current	IDD	No Load, 135 MHz		80		mA
Short Circuit Current, 3.3 V	I _{OS}			±50		mA
Short Circuit Current, 5 V	I _{OS}			±60		mA

Note 1: V_{OH} and V_{OL} can be set by the external resistor values on the PECL outputs.

note 2: IDD includes the current through the external resistors which can be modified.

AC Electrical Characteristics

VDD = 3.3 V ±5, Ambient Temperature -40 to +85 °C

Parameter	Symbol	Conditions	Min.	Typ.	Max.	Units
Input Frequency			0		200	MHz
Propagation Delay		VDD = 3.3 V		2		ns
		VDD = 5 V		2		ns
Output to Output Skew		Crosspoint of pair		0	50	ps
Duty Cycle		Crosspoint of pair	45	50	55	%

Package Outline and Package Dimensions (16-pin TSSOP, 4.40 mm Body, 0.65 mm Pitch)

Package dimensions are kept current with JEDEC Publication No. 95

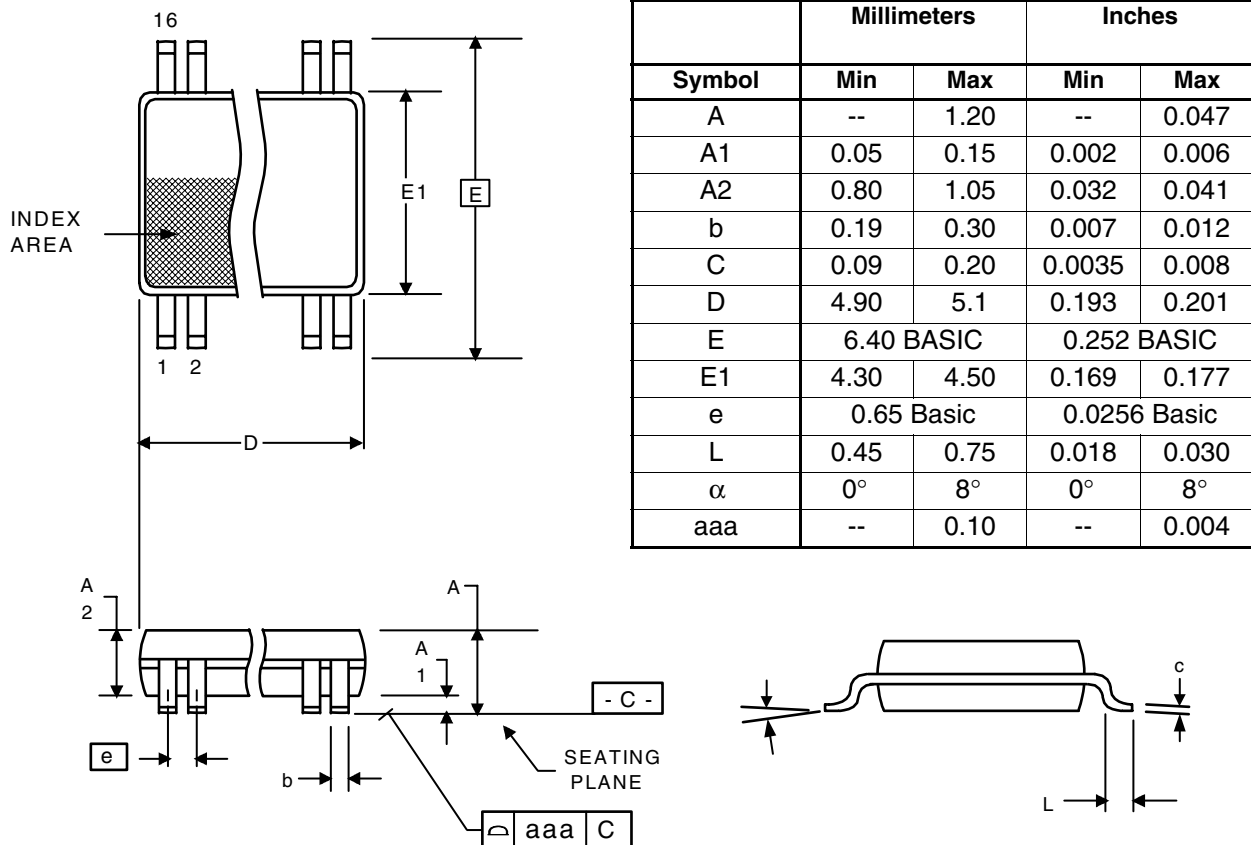

Ordering Information

Part / Order Number	Marking	Shipping Packaging	Package	Temperature
554G-01AILF	554G1AIL	Tubes	16-pin TSSOP	-40 to +85 °C
554G-01AILFT		Tape and Reel	16-pin TSSOP	-40 to +85 °C

“LF” denotes Pb free packaging, RoHS compliant

While the information presented herein has been checked for both accuracy and reliability, Integrated Device Technology (IDT) assumes no responsibility for either its use or for the infringement of any patents or other rights of third parties, which would result from its use. No other circuits, patents, or licenses are implied. This product is intended for use in normal commercial applications. Any other applications such as those requiring extended temperature range, high reliability, or other extraordinary environmental requirements are not recommended without additional processing by IDT. IDT reserves the right to change any circuitry or specifications without notice. IDT does not authorize or warrant any IDT product for use in life support devices or critical medical instruments.

ICS554-01A

LOW SKEW 1 TO 4 CLOCK BUFFER PECL IN, PECL OUT

PECL BUFFER

IMPORTANT NOTICE AND DISCLAIMER

RENESAS ELECTRONICS CORPORATION AND ITS SUBSIDIARIES (“RENESAS”) PROVIDES TECHNICAL SPECIFICATIONS AND RELIABILITY DATA (INCLUDING DATASHEETS), DESIGN RESOURCES (INCLUDING REFERENCE DESIGNS), APPLICATION OR OTHER DESIGN ADVICE, WEB TOOLS, SAFETY INFORMATION, AND OTHER RESOURCES “AS IS” AND WITH ALL FAULTS, AND DISCLAIMS ALL WARRANTIES, EXPRESS OR IMPLIED, INCLUDING, WITHOUT LIMITATION, ANY IMPLIED WARRANTIES OF MERCHANTABILITY, FITNESS FOR A PARTICULAR PURPOSE, OR NON-INFRINGEMENT OF THIRD PARTY INTELLECTUAL PROPERTY RIGHTS.

These resources are intended for developers skilled in the art designing with Renesas products. You are solely responsible for (1) selecting the appropriate products for your application, (2) designing, validating, and testing your application, and (3) ensuring your application meets applicable standards, and any other safety, security, or other requirements. These resources are subject to change without notice. Renesas grants you permission to use these resources only for development of an application that uses Renesas products. Other reproduction or use of these resources is strictly prohibited. No license is granted to any other Renesas intellectual property or to any third party intellectual property. Renesas disclaims responsibility for, and you will fully indemnify Renesas and its representatives against, any claims, damages, costs, losses, or liabilities arising out of your use of these resources. Renesas' products are provided only subject to Renesas' Terms and Conditions of Sale or other applicable terms agreed to in writing. No use of any Renesas resources expands or otherwise alters any applicable warranties or warranty disclaimers for these products.

(Disclaimer Rev.1.0 Mar 2020)

Corporate Headquarters

TOYOSU FORESIA, 3-2-24 Toyosu,
Koto-ku, Tokyo 135-0061, Japan
www.renesas.com

Contact Information

For further information on a product, technology, the most up-to-date version of a document, or your nearest sales office, please visit:
www.renesas.com/contact/

Trademarks

Renesas and the Renesas logo are trademarks of Renesas Electronics Corporation. All trademarks and registered trademarks are the property of their respective owners.