



ANATECH ELECTRONICS INC
RF & Microwave Filters & Products

1030 MHz Ceramic Bandpass Filter

Part Number: AM1030B1179



Electrical specifications

Center Frequency: 1030 MHz
Bandwidth: 30 MHz min
VSWR: 1.5 : 1 max
Input / Output Impedance: 50 Ohms
Passband: 1015-1045 MHz
Passband Insertion Loss: 3.0 dB max
Passband Ripple: 0.5 dB max
Rejection: 32 dBc min at Fo+/- 70 MHz
Power Handling: 1 W

Mechanical

Mounting Method: SMT
Dimensions: 18.2mm x 14mm x 5mm

Environmental

Operating Temperature: -40°C to 85°C
Storage Temperature: -50°C to +90°C

This product is RoHs compliant.

Outline Drawing:

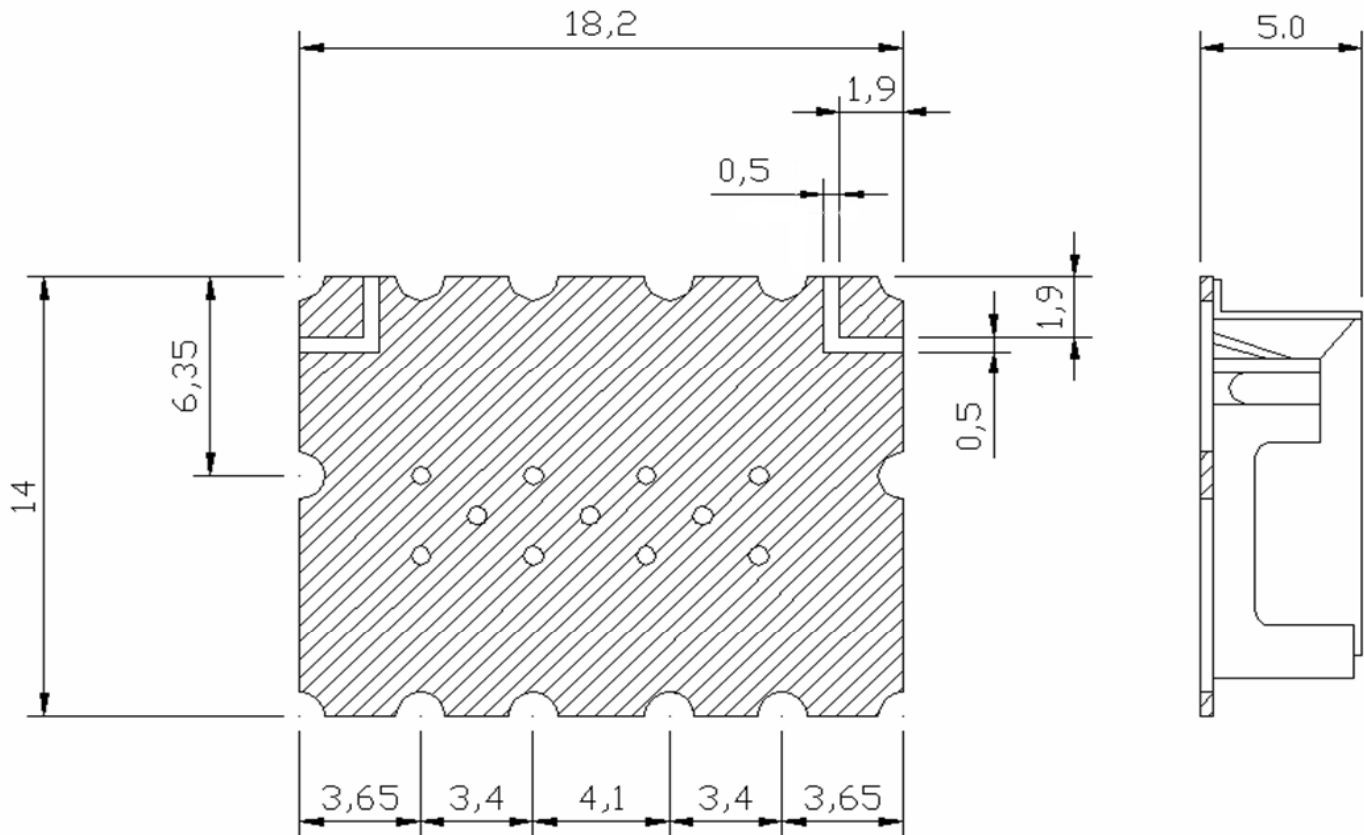

Unit : mm

Tolerance : ± 0.3