

RECOMMENDED MOUNTING HOLES

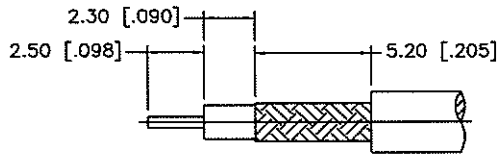

RECOMMENDED CABLE STRIPPING DIM'S

REV.	DATE	ECR NO.	DESCRIPTION
A	04/27/99	-	MODIFY FERRULE/ ADD NOTES 1 AND 2
B	09/29/04	-	MODIFY FERRULE AND CRIMP NOTES
C	09/17/08	-	ADD FLAT TO BODY/ REVISE FERRULE DIMENSIONS/ ADD NOTE 3 REVISE CABLE DESCRIPTION TO 316/U DB CABLE

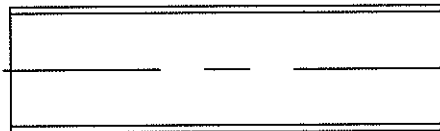
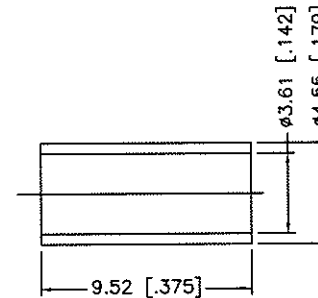
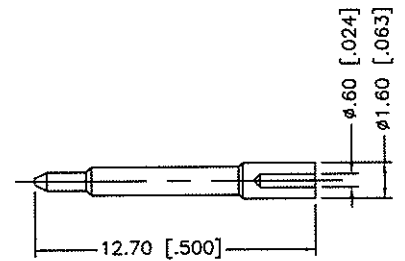
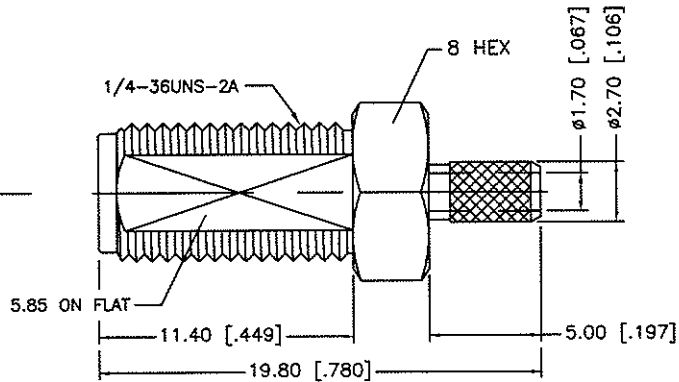
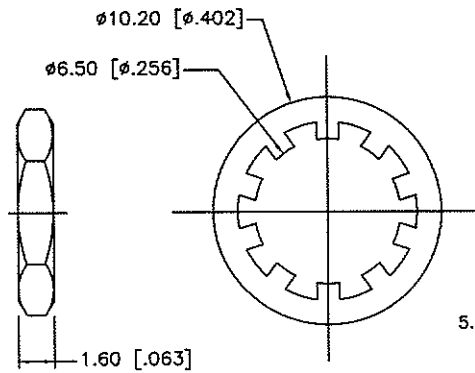

NOTE:

1. CRIMPED FERRULE HEX CRIMP SIZE .151" [3.83]
2. CONTACT PIN TO SOLDER.
3. MAX. PANEL THICKNESS OF 3.20 [1.26"]

DESCRIPTION	MATERIAL	FINISH	QTY
8			
7	HEAT SHRINK TUBING	BLK	A/R
6	FERRULE	COPPER	GOLD 1
5	HEX NUT	BRASS	GOLD 1
4	LOCK WASHER	BRASS	GOLD 1
3	CONTACT PIN	BRASS	GOLD 1
2	INSULATOR	PTFE	NATURAL 1
1	BODY	BRASS	GOLD 1

UNLESS OTHERWISE SPECIFIED DIMENSIONS ARE IN MILLIMETERS. DIMENSIONS IN [] ARE IN INCHES AND FOR CUSTOMER REFERENCE ONLY.

UNLESS OTHERWISE SPECIFIED TOLERANCES FOR MILLIMETERS ARE:
 0.5 - 8mm ± 0.20mm
 8 - 30mm ± 0.40mm
 30 - 120mm ± 0.50mm

UNLESS OTHERWISE SPECIFIED TOLERANCES FOR INCHES ARE:
 .020 - .315 = ± 0.007"
 .315 - 1.180 = ± 0.015"
 1.180 - 4.724 = ± 0.020"

DO NOT SCALE DRAWING

APPROVALS	DATE
DRAWN GRS	09/17/08
CHECKED	
ISSUED	
SHEET 1 OF 1	
CAD FILE C:/132/132176RP.DWG	

Amphenol Connex

PART DESCRIPTION
SMA REVERSE POLARITY BULKHEAD CRIMP JACK (FOR 316/U DOUBLE BRAID CABLE)
PART NO. 132176RP
DWG. NO. 132176RP.DWG
REV. NC
SIZE A
SCALE NA

9/16/08

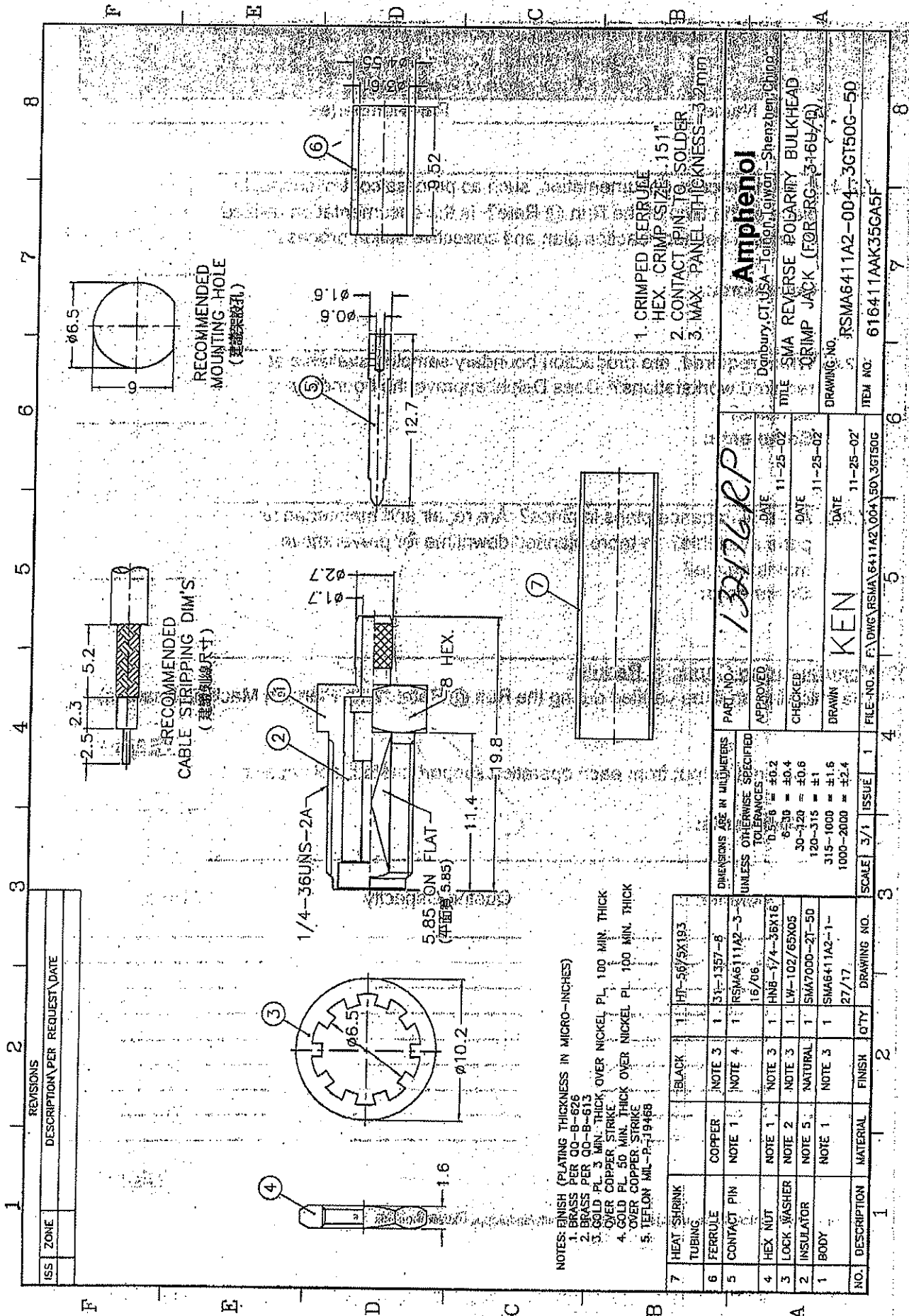

- NOTES: FINISH (PLATING THICKNESS IN MICRO-INCHES)
- BRASS PER QQ-B-626
 - BRASS PER QQ-B-613
 - GOLD PL. 3 MIN. THICK, OVER NICKEL PL. 100 MIN. THICK OVER COPPER STRIKE
 - GOLD PL. 50 MIN. THICK OVER NICKEL PL. 100 MIN. THICK OVER COPPER STRIKE
 - TEFLON MIL-P-19468

- CRIMPED FERRULE HEX CRIMP SIZE .151"
- CONTACT PIN TO SOLDER
- MAX. PANEL THICKNESS = 3.2mm

NO.	DESCRIPTION	MATERIAL	FINISH	Q'TY	DRAWING NO.	SCALE	ISSUE	1	4	3
7	HEAT SHRINK TUBING	BLACK		1	HT-56/5X193					
6	FERRULE	COPPER	NOTE 3	1	31-1357-B					
5	CONTACT PIN	NOTE 1	NOTE 4	1	RSMA6111A2-3-16/06					
4	HEX NUT	NOTE 1	NOTE 3	1	HNB-5/4-3BX16					
3	LOCK WASHER	NOTE 2	NOTE 3	1	LW-102/65X05					
2	INSULATOR	NOTE 5	NATURAL	1	SMAT000-2T-50					
1	BODY	NOTE 1	NOTE 3	1	SMAG411A2-1-27/17					

APPROVED	DATE	CHECKED	DATE	DRAWN	DATE
<i>132176RP</i>	11-25-02		11-25-02	KEN	11-25-02

Amphenol
 Danbury, CT, USA - London, England - Shenzhen, China

TITLE: SMA REVERSE POLARITY BULKHEAD CRIMP JACK (FOR RC-316U/B)

DRAWING NO.: RSMA6411A2-004-3GT50G-50

ITEM NO.: 616411AAK35GASF

ISS	ZONE	REVISIONS	DESCRIPTION	PER	REQUEST	DATE
1						

Old

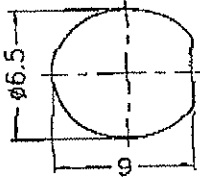
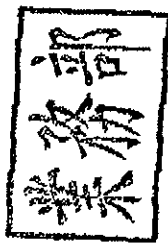

RECOMMENDED MOUNTING HOLE

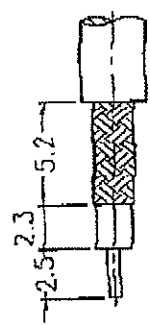

RECOMMENDED CABLE STRIPPING DIM'S

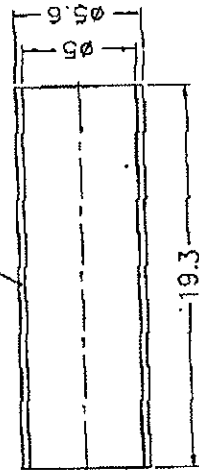
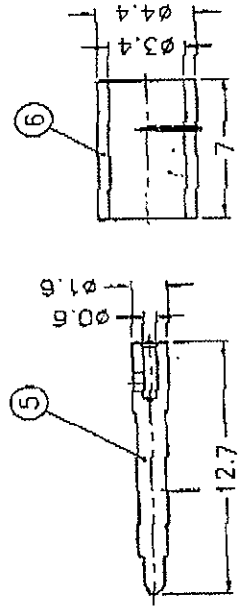
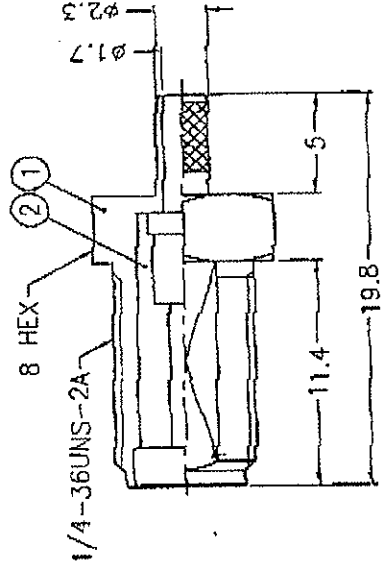
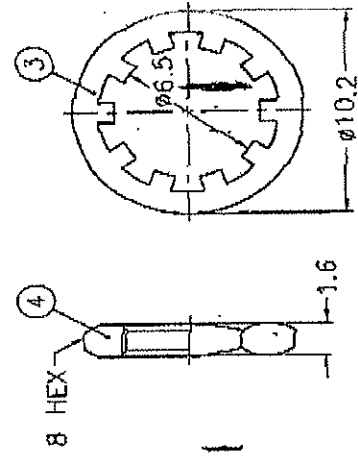

- NOTES: 1. PER KAI JACK SPEC. EP-SS-9700
 2. BRASS PER QQ-B-826
 3. STAINLESS STEEL, FED. QQ-S-764, TYPE 303
 4. BRASS PER QQ-B-813
 5. TEFLON MIL-P-19468

ISS	ZONE	REVISIONS	DESCRIPTION	APPROVED	DATE
B	B-1		NO.6 WAS CHANGED TO NYLON TYPE 05-08-98'		
	A-1		NO.1 WAS CHANGED TO NYLON TYPE 05-18-98'		

NO.	DESCRIPTION	MATERIAL	FINISH	QTY	DRAWING NO.	SCALE	3/1	ISSUE	B
7	HEAT SHRINK TUBING				HT-56/5X193				
6	FERRULE	COPPER	NOTE 1	1	FR-44/34X7C				
5	CONTACT PIN		NOTE 4	1	RSMA6411A2-3-15/06				
4	HEX NUT		NOTE 2	1	JMB-1/4-36X16				
3	LOCK WASHER		NOTE 3	1	LW-102/65X05				
2	INSULATOR		NOTE 5	1	SNAT000-2T-50				
1	BODY		NOTE 2	1	SMAB411A2-1-23/17-C				

REVISIONS	DATE	APPROVED	DATE
APPROVED	07-01-98'		
CHECKED	07-01-98'		
DRAWN	07-01-98'		

PART NO.	132176 RP
TITLE	CRIMP PINK Reverse POLARIZ-D
MANUFACTURER	KAI JACK INDUSTRIAL CO., LTD. TAINAN TAIWAN R.O.C.
DESCRIPTION	SMA REVERSE BULKHEAD CRIMP JACK
DRAWING NO.	132176 RP
FILE NO.	F:\0\WG\RSMA\6411A2\316UD-50

8 SMA-R15-9