

APPROVED: \_\_\_\_\_  
 DATE: \_\_\_\_\_ TITLE: \_\_\_\_\_

|     |       |             |         |      |
|-----|-------|-------------|---------|------|
| Rev | AWO # | Description | Date    | Appr |
| -   |       | RELEASED    | 5/26/20 |      |

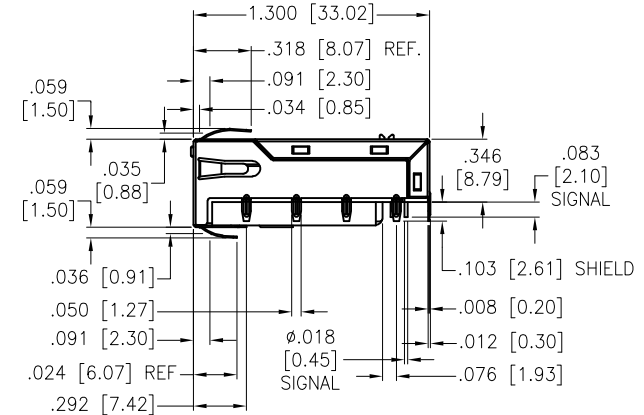

**SPECIFICATIONS:**  
 Material:  
 Insulator: (PA10T) Hi-Temp Thermoplastic, rated UL 94V-0, Color: Black  
 Contacts: Phosphor Bronze  
 Shield Pin: Solder With Matte Tin  
 Plating:  
 Round contact  
 Gold over Nickel underplate overall  
 Flat contact  
 Gold over Nickel underplate on contact area,  
 Tin over Nickel underplate on solder tails  
 Electrical:  
 Current rating: 0.1 Amperes Maximum  
 Voltage rating: 48 VDC Maximum  
 Insulation resistance: 500 Mohms min  
 Dielectric withstanding voltage: 2250 VDC Contact To Shield  
 Temperature Rating:  
 Operating temperature: 0°C to +70°C  
 Agency Certifications:  
 UL Recognized   
 Environmental:  
 Lead free, RoHS compliant.

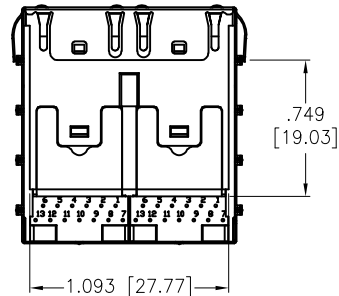
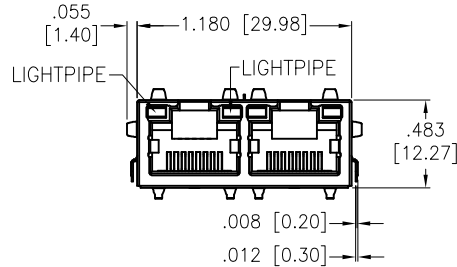
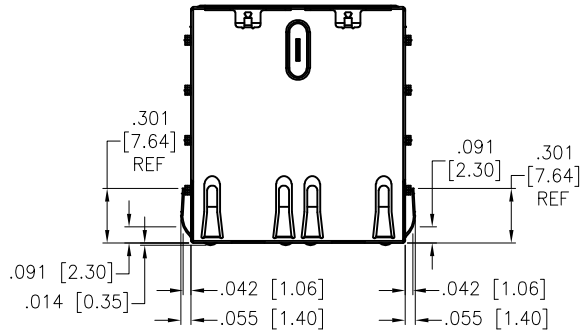
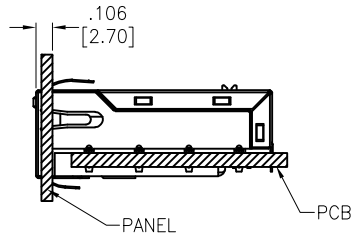
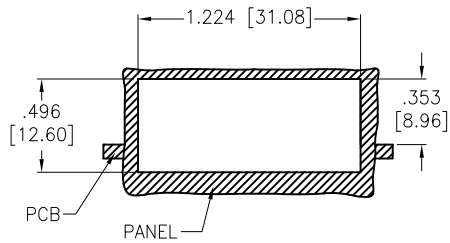

|   |              |         |
|---|--------------|---------|
| UNLESS OTHERWISE SPECIFIED<br>ALL DIMENSIONS ARE INCHES [MM]<br>TOLERANCES: EXCEPT AS NOTED |              |         |
| INCHES  |              | HOLES   |
| .X ± .10  | Ø.X ± .10    |         |
| .XX ± .020  | Ø.XX ± .015  |         |
| .XXX ± .015   | Ø.XXX ± .010 |         |
| APPROVALS   |              | DATE    |
| DRAWN   | OW           | 5/26/20 |
| CHECKED   | AC           | 5/26/20 |
| APPROVED  |              |         |

**ADAM TECH**  
 INTERCONNECTS  
 909 Rahway Avenue,  
 Union, NJ 07083  
 Phone: 908-687-5000  
 Fax: 908-687-5710

|  |  |              |
|--|--|--------------|
| TITLE<br>GANGED MODULAR TELEPHONE JACK, 8P8C, 10G BASE-T,<br>2 PORT, SHIELD, PANEL GROUND, LIGHTPIPE |  |              |
| SIZE<br>X  | PART NO.<br>MTJG-2-88CEX1-FS-PG-WLP-M370C-HT | REV.<br>-    |
| REF: S00005C   | SCALE: NTS                                   | SHEET 1 OF 3 |

6

5

4

3

2

1

APPROVED: \_\_\_\_\_

DATE: \_\_\_\_\_ TITLE: \_\_\_\_\_

| Rev | AWO # | Description | Date | Appr |
|-----|-------|-------------|------|------|
|-----|-------|-------------|------|------|

SEE SHT 1 OF 3 FOR REVISION

|    |       |
|----|-------|
| 1  | TRD1+ |
| 2  | TRD1- |
| 3  | TRD3+ |
| 4  | TRD3- |
| 5  | CMS+  |
| 6  | CMS-  |
| 7  | TRCT1 |
| 8  | TRD2- |
| 9  | TRD2+ |
| 10 | TRCT3 |
| 11 | TRD4- |
| 12 | TRD4+ |
| 13 | TCT4  |

PIN ASSIGNMENT  
(EACH PORT)

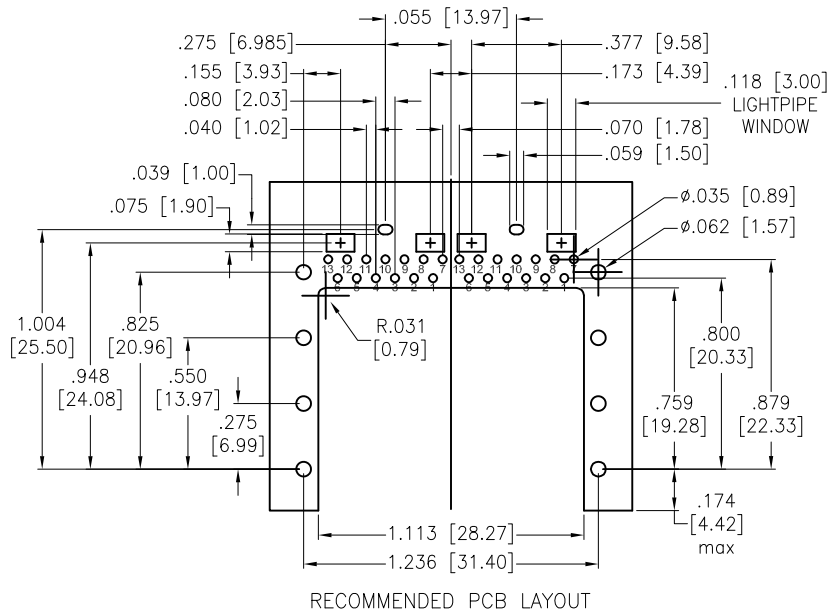

D

D

C

C

B

B

A

A

6

5

4

3

2

1

UNLESS OTHERWISE SPECIFIED  
ALL DIMENSIONS ARE INCHES [MM]  
TOLERANCES: EXCEPT AS NOTED

|      |        |       |        |
|------|--------|-------|--------|
| .X   | ± .10  | ∅.X   | ± .10  |
| .XX  | ± .020 | ∅.XX  | ± .015 |
| .XXX | ± .015 | ∅.XXX | ± .010 |

**ADAM**  
**TECH**  
**INTERCONNECTS**

909 Rahway Avenue,  
Union, NJ 07083  
Phone: 908-687-5000  
Fax: 908-687-5710

| APPROVALS |    | DATE    |
|-----------|----|---------|
| DRAWN     | OW | 5/26/20 |
| CHECKED   | AC | 5/26/20 |
| APPROVED  |    |         |

|   |                                  |              |
|---|----------------------------------|--------------|
| TITLE   |                                  |              |
| GANGED MODULAR TELEPHONE JACK, 8P8C, 10G BASE-T,<br>2 PORT, SHIELD, PANEL GROUND, LIGHTPIPE |                                  |              |
| SIZE  | PART NO.                         | REV.         |
| X   | MTJG-2-88CEX1-FS-PG-WLP-M370C-HT | -            |
| REF:  | S00005C                          | SCALE: NTS   |
|   |                                  | SHEET 2 OF 3 |

6 5 4 3 2 1

APPROVED: \_\_\_\_\_  
 DATE: \_\_\_\_\_ TITLE: \_\_\_\_\_

| Rev                         | AWO # | Description | Date | Appr |
|-----------------------------|-------|-------------|------|------|
| SEE SHT 1 OF 3 FOR REVISION |       |             |      |      |

UNLESS OTHERWISE SPECIFIED  
 ALL DIMENSIONS ARE INCHES [MM]  
 TOLERANCES: EXCEPT AS NOTED

| INCHES |        | HOLES |        |
|--------|--------|-------|--------|
| .X     | ± .10  | Ø.X   | ± .10  |
| .XX    | ± .020 | Ø.XX  | ± .015 |
| .XXX   | ± .015 | Ø.XXX | ± .010 |

| APPROVALS |    | DATE    |
|-----------|----|---------|
| DRAWN     | OW | 5/26/20 |
| CHECKED   | AC | 5/26/20 |
| APPROVED  |    |         |

**ADAM TECH INTERCONNECTS** 909 Rahway Avenue,  
 Union, NJ 07083  
 Phone: 908-687-5000  
 Fax: 908-687-5710

TITLE  
 GANGED MODULAR TELEPHONE JACK, 8P8C, 10G BASE-T,  
 2 PORT, SHIELD, PANEL GROUND, LIGHTPIPE

|              |  |              |
|--------------|--|--------------|
| SIZE<br>X    | PART NO.<br>MTJG-2-88CEX1-FS-PG-WLP-M370C-HT | REV.<br>-    |
| REF: S00005C | SCALE: NTS                                   | SHEET 3 OF 3 |

6 5 4 3 2 1