

UNIT:MM

REVISION INFORMATION

Rev.	Rev. Date	Modified By	Brief Description
A/0	18-07-05	T0704B	NEW DRAWING
A/1	18-07-30	T0730A	Modify SR color code

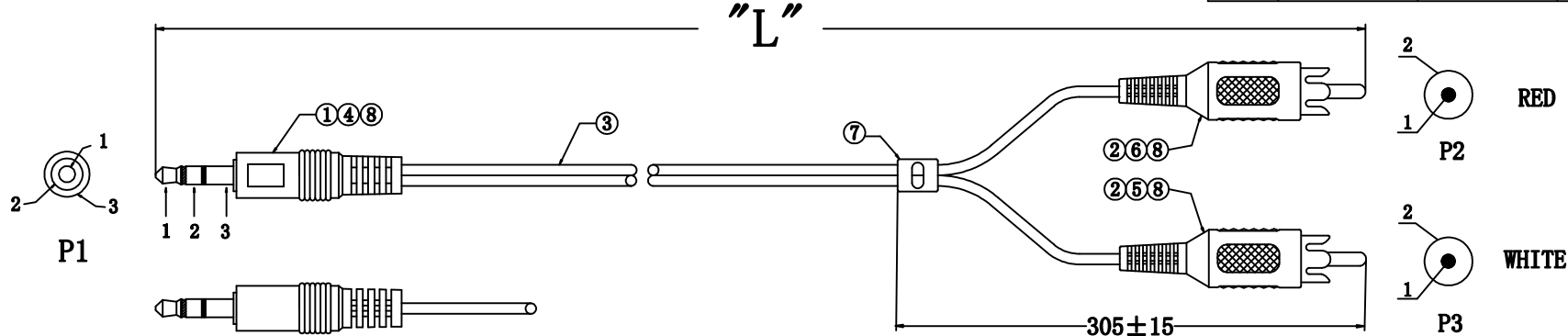

Electrical test:
 1. 100% short, open, miswire test
 2. Conduct resistance: 2 Ohm (max)
 3. Insulation resistance: 10 Mohm (min)
 4. dielectric test: DC 300V

PIN ASSIGNMENT

P1	P2	P3	COLOR
1	1		RED
2		1	BLACK
3	2		DRAIN (RED)
	2		DRAIN (BLACK)

PART NO	WIRE LENGTH "L"	BUYER COLOR	VENDOR COLOR	CUT LENGTH
770-10043-00150	1500 ± 50		BLACK	1480-1490MM

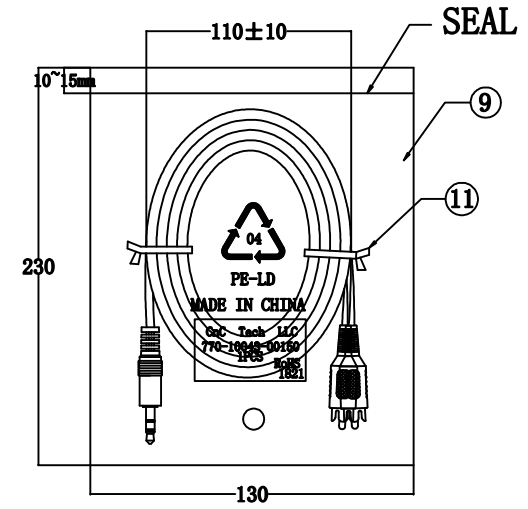

NO.	NAME	QTY	SPECIFICATION
①	TIE	2	BLACK L=90MM
⑩	PE BAG	1/10	CLEAR SIZE: 280*330*0.05mm PRINT BLACK "MADE IN CHINA"+10PC"
⑨	PE BAG	1	CLEAR SIZE: 130*230*0.05mm PRINT BLACK "MADE IN CHINA"+1PC"
⑥	TUBE	3	HEAT SHRINK TUBE BLACK OD1.5*10mm
⑦	SR	1.0g	BLACK PVC 40P (Mould NO. :SR-048)
⑥	IN JACKET	0.8g	CLEAR LD-PE (Mould NO. :NM-006)
	OUT JACKET	3.3g	PVC-40P RED (R1-064) (Mould NO. :WM-009)
⑤	IN JACKET	0.8g	CLEAR LD-PE (Mould NO. :NM-006)
	OUT JACKET	3.3g	PVC-40P WHITE (W-166) (Mould NO. :WM-009)
④	OUT JACKET	3.0g	BLACK PVC-40P (Mould NO. :WM-020)
③	CABLE	1	NOUL [(0.12/7)+(30/0.12)]*2F JACKET BLACK OD2.8*5.6mm
②	CONN	2	RCA PLUG MALE BLOSSOM TYPE NI-PLATED INSULATOR COLOR: BROWN
①	CONN	1	3.5ST MALE Tray 6.0mm L=26mm MOLD TYPE NI-PLATED INSULATOR COLOR: BLACK

CnC Tech, LLC
 Industrial Cable and Connector Technology

DRAWN BY:	DATE: 2018/07/30	DESCRIPTION: 2F CABLE DC3.5+RCAx2
CHECKED BY:	SHEET 1 of 1	ITEM NO. As above
APPROVED BY:	SCALE 1:1	REV. A/1