

THIS DOCUMENT IS THE PROPERTY OF KEYSTONE ELECTRONICS CORP. AND SHALL NOT BE REPRODUCED, DISTRIBUTED OR USED AS A BASIS FOR MANUFACTURE WITHOUT PRIOR WRITTEN PERMISSION FROM KEYSTONE ELECTRONICS CORP.

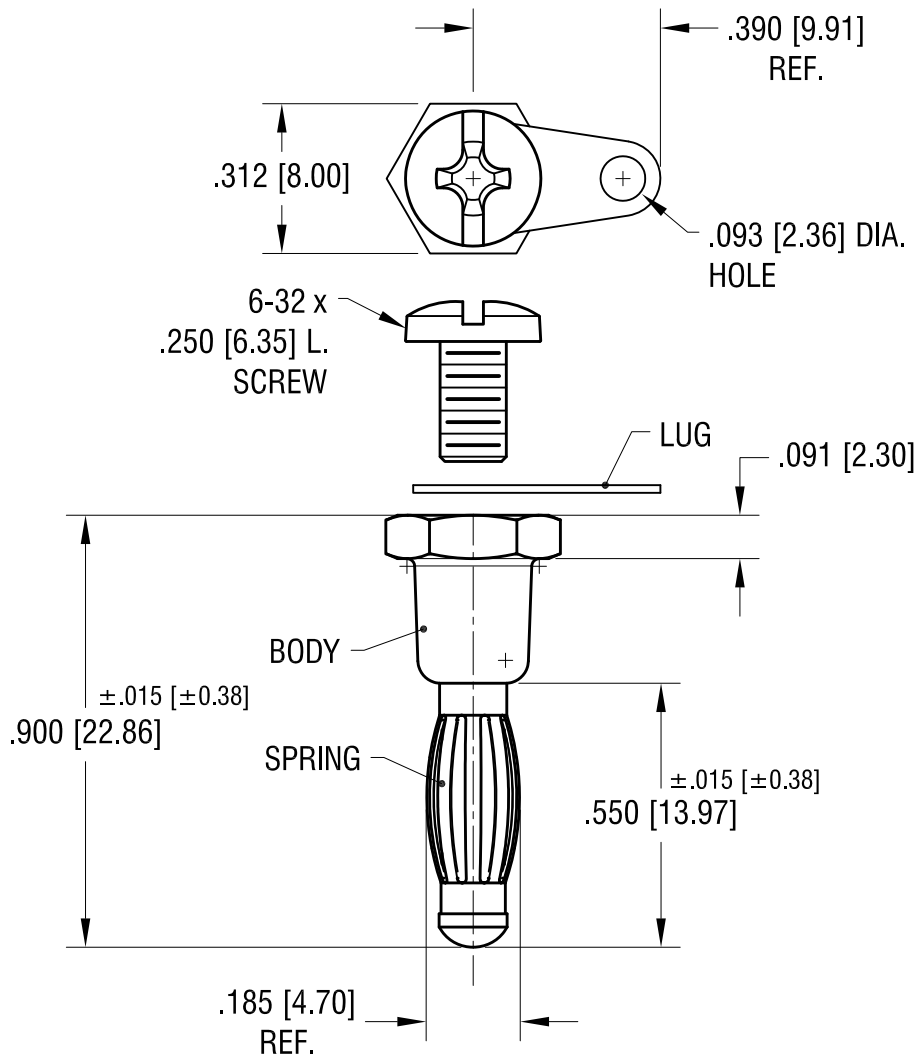

ACTUAL SIZE



NOTES:

- 1. SPRING: MAT'L - BERYLLIUM COPPER
FINISH - NICKEL PLATE
- BODY: MAT'L - BRASS
FINISH - NICKEL PLATE
- SCREW: MAT'L - BRASS
FINISH - NICKEL PLATE
- LUG: MAT'L - BRASS
FINISH - TIN PLATE
- 2. SCREW AND LUG SUPPLIED UNASSEMBLED.

KEYSTONE ELECTRONICS CORP.			
www.keyelco.com • ASTORIA, N.Y. 11105-2017 • Tel (718) 956-8900			
PART NAME			
INTERNAL THREAD BANANA PLUG			
MATERIAL			
AS NOTED			
FINISH		DRN BY	DATE
AS NOTED		NT	7.19.10
		APP'D	SCALE
		LN	2.5X
TOLERANCES	INCH [MM]	CODE	DWG NO.
DECIMAL	± .005 [± 0.13]	C	659
ANGULAR	± 1°		
UNLESS OTHERWISE SPECIFIED			

7.06.12	CHANGE AS PER ECN 12-083	A
DATE	DESCRIPTION	REV.