

NUT

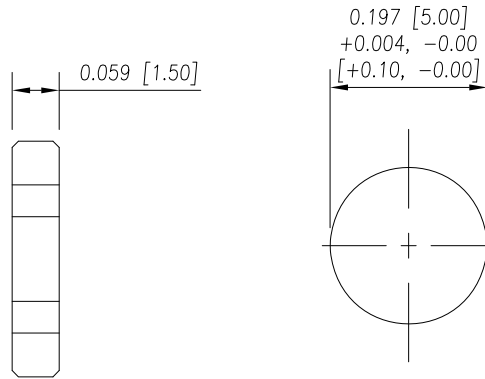

RECOMMEND PANEL CUT-OUT  
MAX. PANEL THICKNESS: 0.200" [5.08]

NOTE:

MATERIAL

HOUSING: PBT UL94V-0, BLACK  
CONTACT: BRASS  
NUT: BRASS  
SHELL: BRASS  
O-RING: NBR, BLACK

FINISH

CONTACT: GOLD PLATED  
OVER 50µ" NICKEL  
NUT: NICKEL PLATED  
SHELL: NICKEL PLATED

ELECTRICAL

RATED CURRENT: 1A  
RATED VOLTAGE: 60V  
INSULATION RESISTANCE: 100 MΩhms MIN.  
CONTACT RESISTANCE: 10 mΩhms MAX.  
WATER PROOF: IP67

ENVIRONMENT

OPERATION TEMPERATURE: -40°C TO +85°C  
WIRE GAUGE: 28 AWG MAX RECOMMENDED

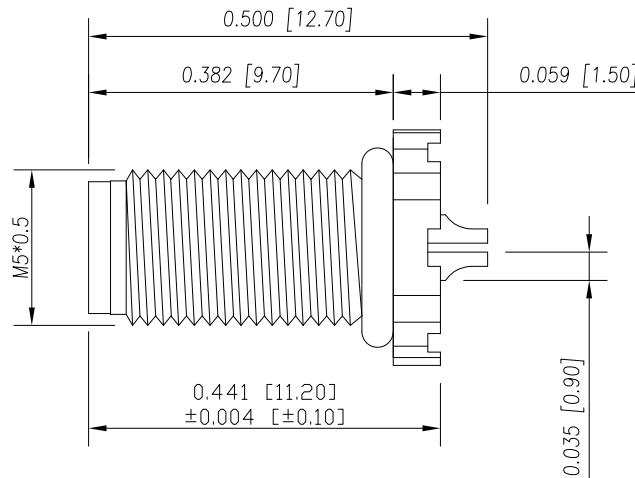
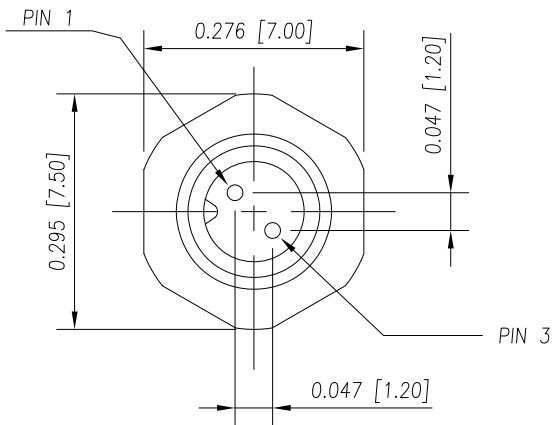

851-002-103R00Y

1 = GOLD FLASH  
4 = 10µ" GOLD

RoHS COMPLIANT

UNITS = INCHES [MM]

DO NOT SCALE FROM DRAWING



THESE DRAWINGS AND SPECIFICATIONS ARE THE PROPERTY OF NorComp AND SHALL NOT BE REPRODUCED, COPIED OR USED AS THE BASIS FOR THE MANUFACTURE OR SALE OF APPARATUS WITHOUT WRITTEN PERMISSION.

DRAWN: M. SIGMON

DATE: 03-03-16

NorComp

SCALE: NTS

SHEET OF 1 1

REV 5

DWG NO. 851-002-103R00Y